

**Descriptions**

- General purpose application
- Switching application

**Features**

- Low Leakage current
- Low collector saturation voltage enabling low voltage operation
- Complementary pair with PN2222A

**Ordering Information**

Type NO.	Marking	Package Code
PN2907A	PN2907A	TO-92

**Outline Dimensions**

unit : mm

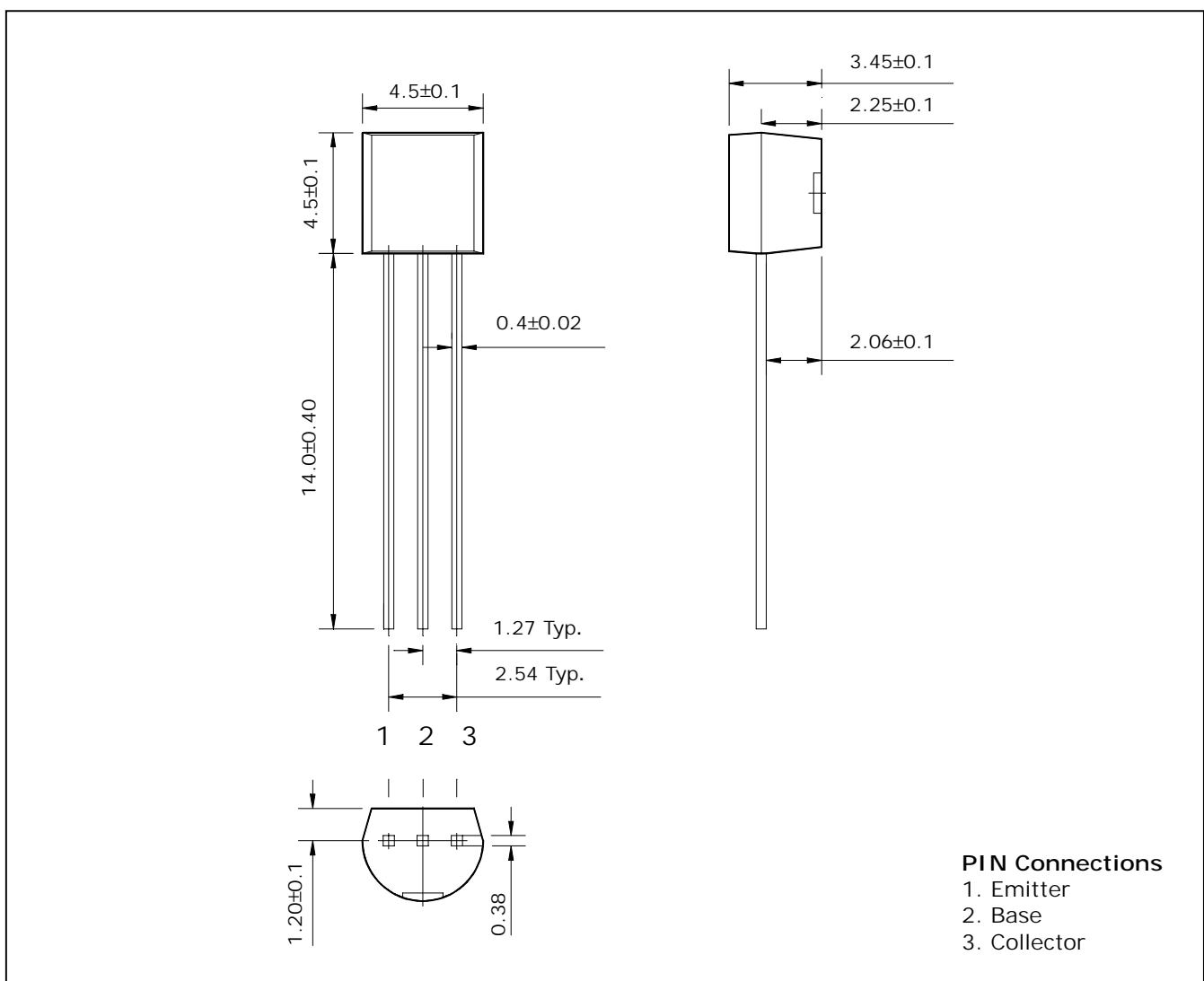

## Absolute maximum ratings

Ta=25°C

Characteristic	Symbol	Ratings	Unit
Collector-Base voltage	$V_{CBO}$	-60	V
Collector-Emitter voltage	$V_{CEO}$	-60	V
Emitter-base voltage	$V_{EBO}$	-5	V
Collector current	$I_C$	-600	mA
Collector dissipation	$P_C$	625	mW
Junction temperature	$T_J$	150	°C
Storage temperature range	$T_{stg}$	-55 ~ 150	°C

## Electrical Characteristics

Ta=25°C

Characteristic	Symbol	Test Condition	Min.	Typ.	Max.	Unit
Collector-Base breakdown voltage	$BV_{CBO}$	$I_C = -10\mu A, I_E = 0$	-60	-	-	V
Collector-Emitter breakdown voltage	$BV_{CEO}$	$I_C = -10mA, I_B = 0$	-60	-	-	V
Emitter-Base breakdown voltage	$BV_{EBO}$	$I_E = -10\mu A, I_C = 0$	-5	-	-	V
Collector cut-off current	$I_{CBO}$	$V_{CB} = -60V, I_E = 0$	-	-	-20	nA
DC current gain	$h_{FE}$	$V_{CE} = -10V, I_C = -10mA$	100	-	-	-
Collector-Emitter saturation voltage	$V_{CE(sat)}$	$I_C = -150mA, I_B = -15mA$	-	-	-0.4	V
Transition frequency	$f_T$	$V_{CE} = -5.0V, I_C = -20mA, f = 100MHz$	200	-	-	MHz
Collector output capacitance	$C_{ob}$	$V_{CB} = -10V, I_E = 0, f = 1MHz$	-	-	8	pF
Turn-on time	$t_{on}$	$V_{CC} = -30V_{dc}, I_C = -150mA_{dc}, I_{B1} = -15mA_{dc}$	-	-	45	ns
Delay time	$t_d$		-	-	10	ns
Rise time	$t_r$		-	-	40	ns
Turn-off time	$t_{off}$	$V_{CC} = -6.0V_{dc}, I_C = -150mA_{dc}, I_{B1} = I_{B2} = -15mA_{dc}$	-	-	100	ns
Storage time	$t_s$		-	-	80	ns
Fall time	$t_f$		-	-	30	ns

Electrical Characteristic Curves

Fig. 1  $P_C$ - $T_a$

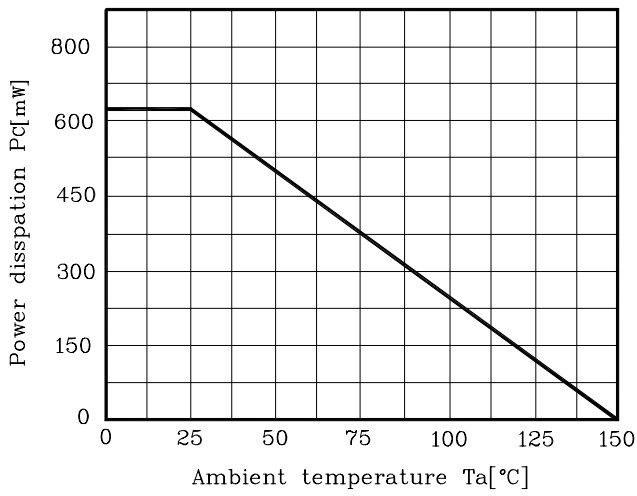

Fig. 2  $h_{FE}$ - $I_C$

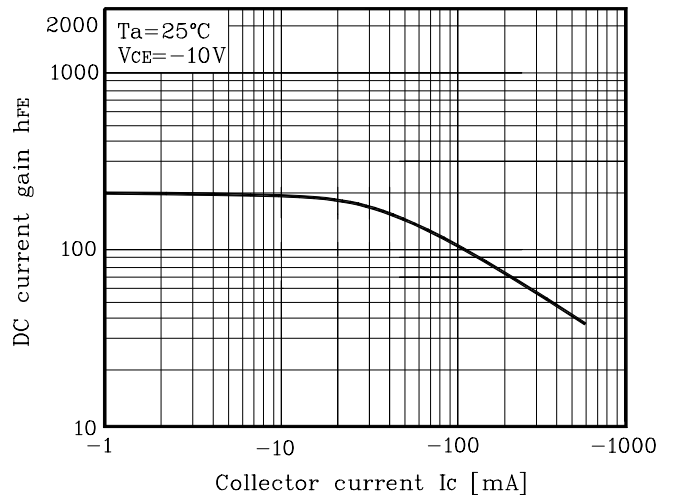

Fig. 3  $V_{CE(sat)}$ - $I_C$

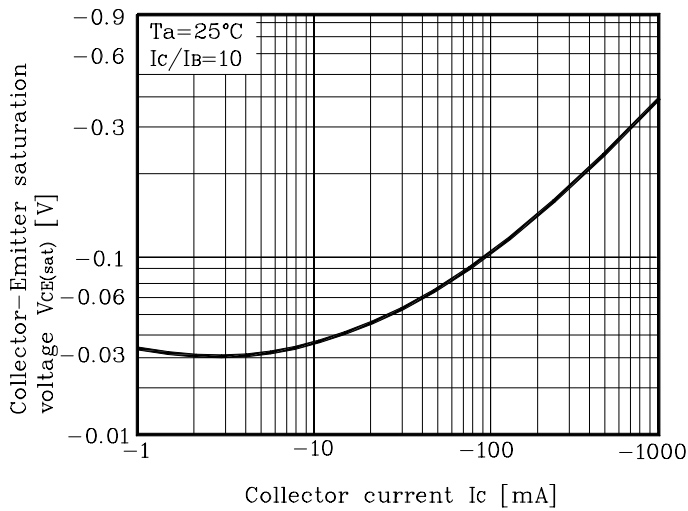

Fig. 4  $C_{ob}$ - $V_{CB}$

