

# GP2L22

## Subminiature, High Sensitivity Photointerrupter

### ■ Features

1.  $\phi$  4mm compact resin mold type
2. High sensitivity ( $I_C$ : MIN. 0.5mA at  $I_F = 4mA$ )
3. Optimum detection distance: 0.6mm
4. Visible light cut-off type

### ■ Applications

1. Audio equipment, VCRs

### ■ Outline Dimensions

(Unit : mm)

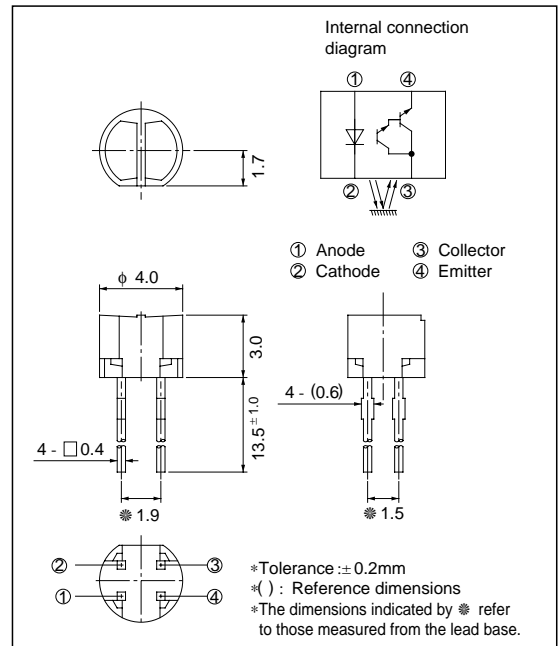

### ■ Absolute Maximum Ratings

(Ta = 25°C)

Parameter		Symbol	Rating	Unit
Input	Forward current	$I_F$	50	mA
	Reverse voltage	$V_R$	6	V
	Power dissipation	P	75	mW
Output	Collector-emitter voltage	$V_{CEO}$	35	V
	Emitter-collector voltage	$V_{ECO}$	6	V
	Collector current	$I_C$	50	mA
	Collector power dissipation	$P_C$	75	mW
Total power dissipation		$P_{tot}$	100	mW
Operating temperature		$T_{opr}$	- 25 to + 85	°C
Storage temperature		$T_{sg}$	- 40 to + 100	°C
*1 Soldering temperature		$T_{sol}$	260	°C

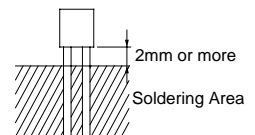

\*1 For 3 seconds by manual soldering

**Electro-optical Characteristics**

( $T_a = 25^\circ\text{C}$ )

Parameter		Symbol	Conditions	MIN.	TYP.	MAX.	Unit	
Input	Forward voltage	$V_F$	$I_F = 20\text{mA}$	-	1.2	1.4	V	
	Reverse current	$I_R$	$V_R = 6\text{V}$	-	-	10	$\mu\text{A}$	
Output	Collector dark current	$I_{CEO}$	$V_{CE} = 10\text{V}$	-	-	$10^{-6}$	A	
Transfer characteristics	<sup>*2</sup> Collector current		$I_C$	$V_{CE} = 5\text{V}, I_F = 4\text{mA}$	0.5	-	15	mA
	Response time	Rise time	$t_r$	$V_{CE} = 2\text{V}, I_C = 10\text{mA}$	-	80	400	$\mu\text{s}$
		Fall time	$t_f$	$R_L = 100\ \Omega, d = 1\text{mm}$	-	70	400	$\mu\text{s}$
	<sup>*3</sup> Leak current		$I_{LEAK}$	$V_{CE} = 5\text{V}, I_F = 4\text{mA}$	-	-	5	$\mu\text{A}$

\*2 The condition and arrangement of the reflective object are shown in the right drawing.

\*3 Without reflective object

The ranking of collector current shall be classified into the following 5 ranks.

Rank	$I_C$ (mA)
A	4.0 to 15.0
B	1.45 to 5.4
A or B	1.45 to 15.0
B or C	0.5 to 5.4
A, B or C	0.5 to 15.0

**Test Condition and Arrangement for Collector Current**

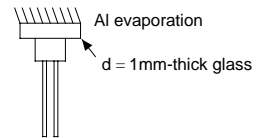

**Fig. 1 Forward Current vs. Ambient Temperature**

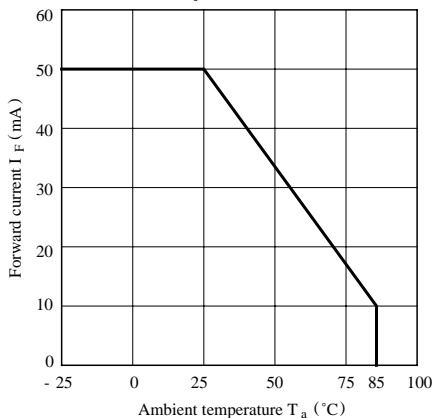

**Fig. 2 Power Dissipation vs. Ambient Temperature**

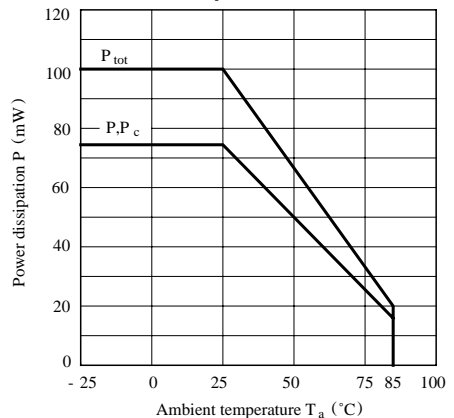

**Fig. 3 Forward Current vs. Forward Voltage**

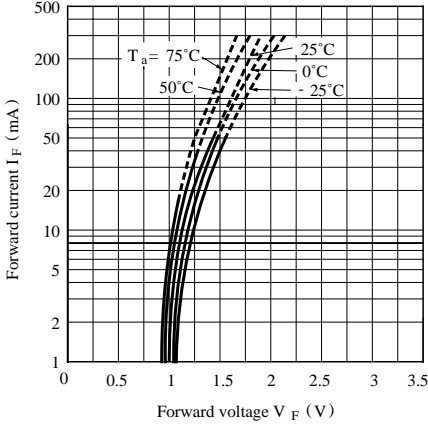

**Fig. 4 Collector Current vs. Forward Current**

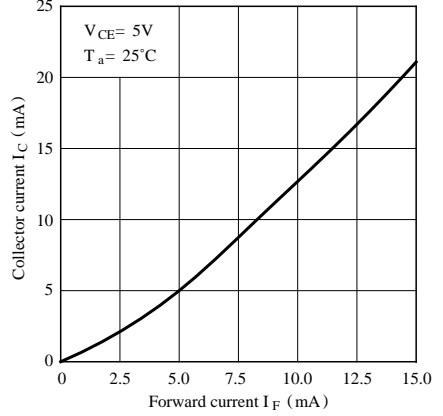

**Fig. 5 Collector Current vs. Collector-emitter Voltage**

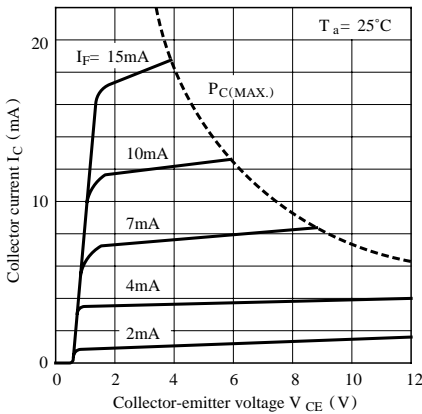

**Fig. 6 Collector Current vs. Ambient Temperature**

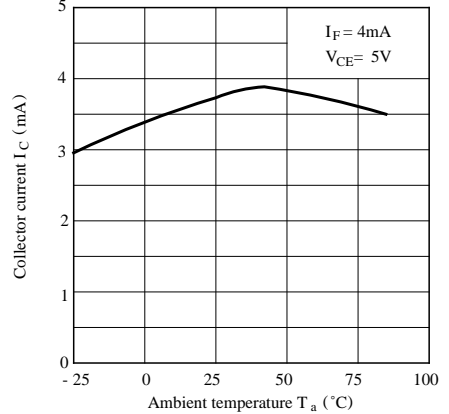

**Fig. 7 Collector Dark Current vs. Ambient Temperature**

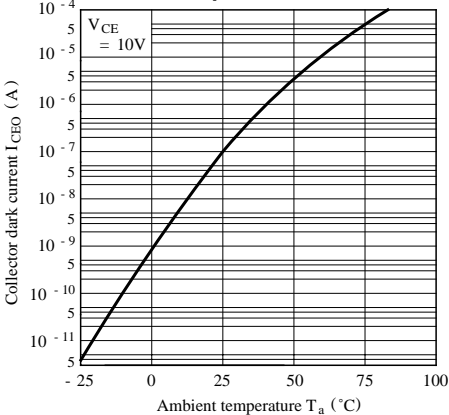

**Fig. 8 Response Time vs. Load Resistance**

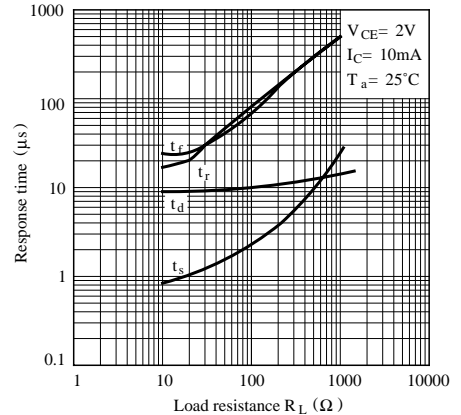

Test Circuit for Response time

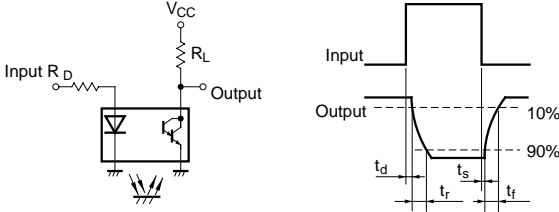

Fig.9 Relative Collector Current vs. Distance between Sensor and Test Card

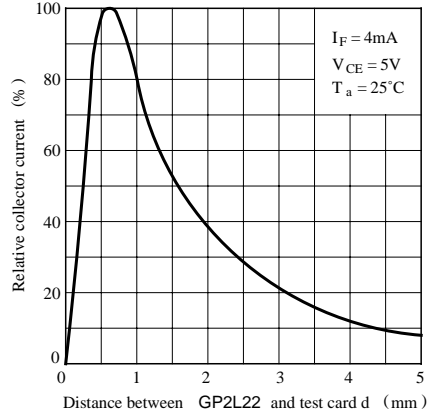
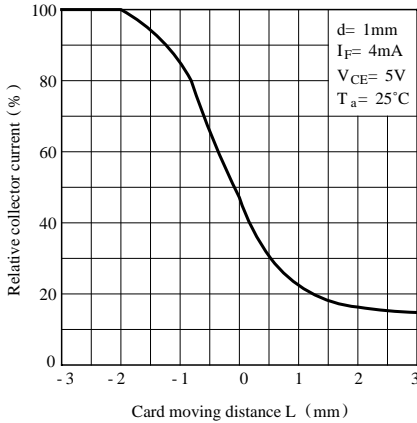

Fig.10 Relative Collector Current vs. Card Moving Distance



Test Condition for Distance & Detecting Position Characteristics

Correspond to Fig.9



Correspond to Fig.10

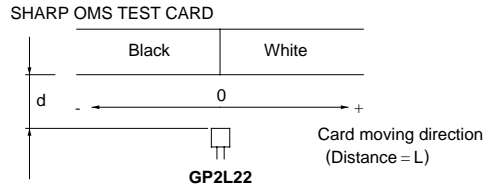

■ Precautions for Use

- (1) Perform soldering manually.
- (2) Please refrain from soldering under preheating and refrain from soldering by reflow.
- (3) As for other general cautions, refer to the chapter “Precautions for Use”.