

FEATURES

- * Dual MOS FETs Cascaded Circuit
- * Low On-Resistance and Switching Dissipation

TYPICAL APPLICATIONS

- * Power Supply for the Communications and the Induction Heating

OUTLINE DRAWING

Dimension(mm)

Circuit

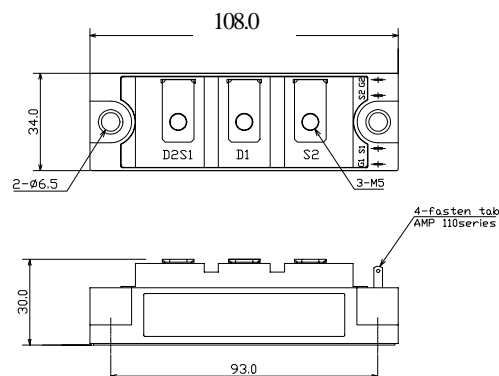
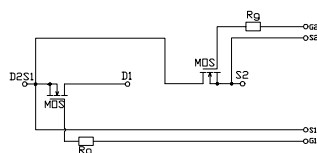

Approximate Weight : 220g

MAXMUM RATINGS

Ratings		Symbol	PD10M441L	PD10M440L	Unit
Drain-Source Voltage ($V_{GS}=0V$)		V_{DSS}	450	500	V
Gate - Source Voltage		V_{GSS}	+/- 20		V
Continuous Drain Current	Duty=50%	I_D	70 ($T_c=25^\circ C$)		A
	D.C.		50 ($T_c=25^\circ C$)		
Pulsed Drain Current		I_{DM}	140 ($T_c=25^\circ C$)		A
Total Power Dissipation		P_D	500 ($T_c=25^\circ C$)		W
Operating Junction Temperature Range		T_{jw}	-40 to +150		$^\circ C$
Storage Temperature Range		T_{sg}	-40 to +125		$^\circ C$
Isolation Voltage (Terminals to Base AC, 1 min.)		V_{ISO}	2000		V
Mounting Torque	Module Base to Heatsink	F_{TOR}	3.0		N•m
	Bus Bar to Main Terminals		2.0		

ELECTRICAL CHARACTERISTICS (@ $T_c=25^\circ C$ unless otherwise noted)

Characteristic	Symbol	Test Condition	Min.	Typ.	Max.	Unit
Zero Gate Voltage Drain Current	I_{DSS}	$V_{DS}=V_{DSS}, V_{GS}=0V$	-	-	1.0	mA
		$T_j=125^\circ C, V_{DS}=V_{DSS}, V_{GS}=0V$	-	-	4.0	
Gate-Source Threshold Voltage	$V_{GS(th)}$	$V_{DS}=V_{GS}, I_D=1mA$	2.0	3.1	4.0	V
Gate-Source Leakage Current	I_{GSS}	$V_{GS}=\pm 20V, V_{DS}=0V$	-	-	1.0	μA
Static Drain-Source On-Resistance	$r_{DS(on)}$	$V_{GS}=10V, I_D=40A$	-	75	85	m-ohm
Forward Transconductance	g_{fs}	$V_{DS}=15V, I_D=40A$	-	65	-	S
Input Capacitance	C_{iss}	$V_{DS}=25V, V_{GS}=0V, f=1MHz$	-	13	-	nF
Output Capacitance	C_{oss}		-	2.2	-	nF
Reverse Transfer Capacitance	C_{rss}		-	0.45	-	nF
Turn-On Delay Time	$t_{d(on)}$	$V_{DD}=1/2V_{DSS}$	-	140	-	ns
Rise Time	t_r	$I_D=40A$	-	110	-	
Turn-Off Delay Time	$t_{d(off)}$	$V_{GS}=-5V, +10V$	-	300	-	
Fall Time	t_f	$R_C=70\Omega$	-	50	-	

FREE WHEELING DIODES RATINGS & CHARACTERISTICS ($T_c=25^\circ C$)

Characteristic	Symbol	Test Condition	Min.	Typ.	Max.	Unit
Continuous Source Current	I_S	D.C.	-	-	50	A
Pulsed Source Current	I_{SM}	-	-	-	140	A
Diode Forward Voltage	V_{SD}	$I_S=70A$	-	-	2.0	V
Reverse Recovery Time	t_{rr}	$I_S=70A, -dis/dt=100A/\mu s$	-	1100	-	ns
Reverse Recovery	Q_r		-	36	-	μC

THERMAL CHARACTERISTICS

Characteristic	Symbol	Test Condition	Min.	Typ.	Max.	Unit
Thermal Resistance, Junction to Case	$R_{th(j-c)}$	MOS FET	-	-	0.25	$^\circ C/W$
		Diode	-	-	0.25	
Thermal Resistance, Case to Heatsink	$R_{th(c-h)}$	Mounting surface flat, smooth, and greased	-	-	0.1	$^\circ C/W$

PD10M44xL

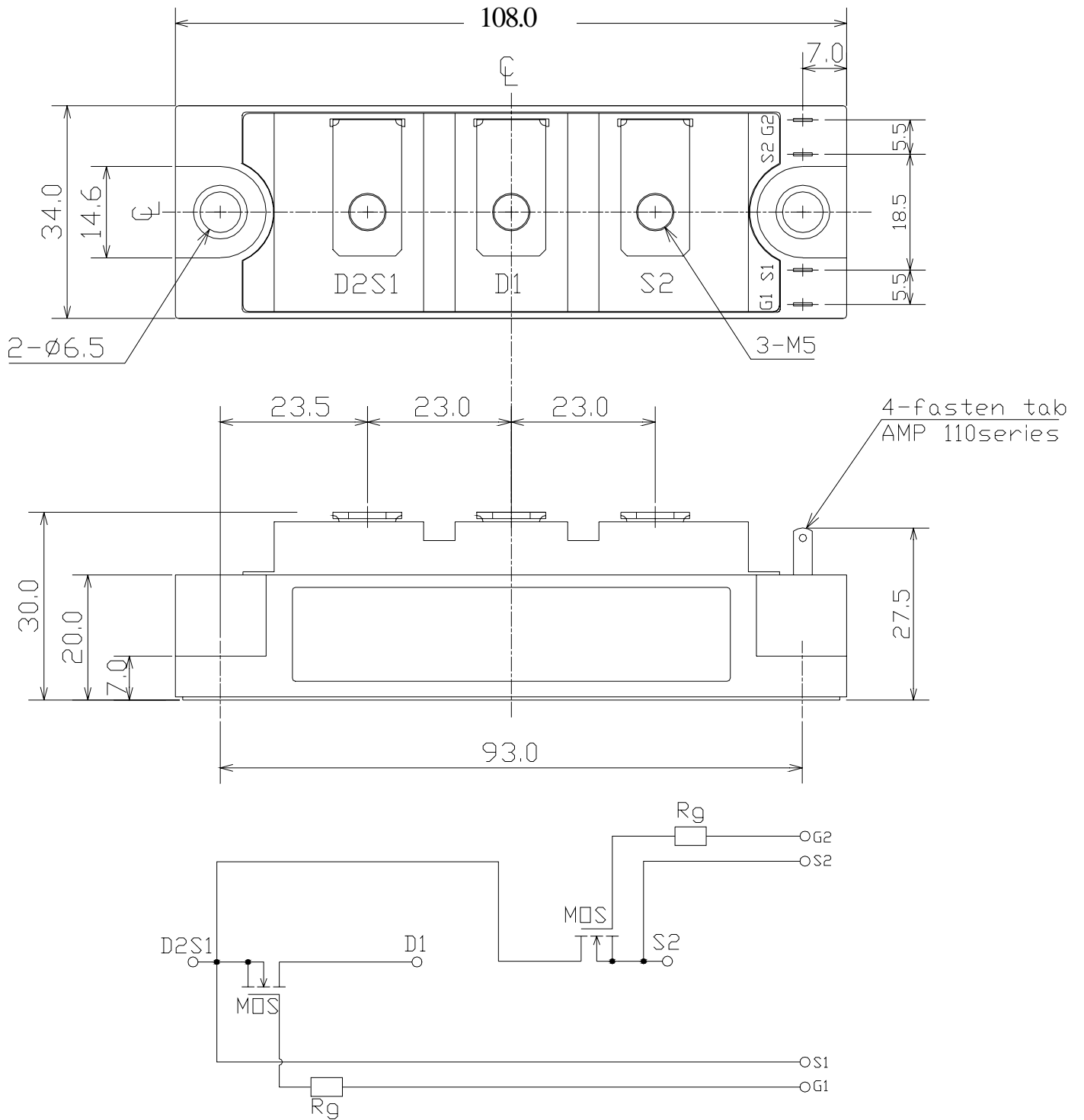

Fig.1- Output Characteristics (Typical)

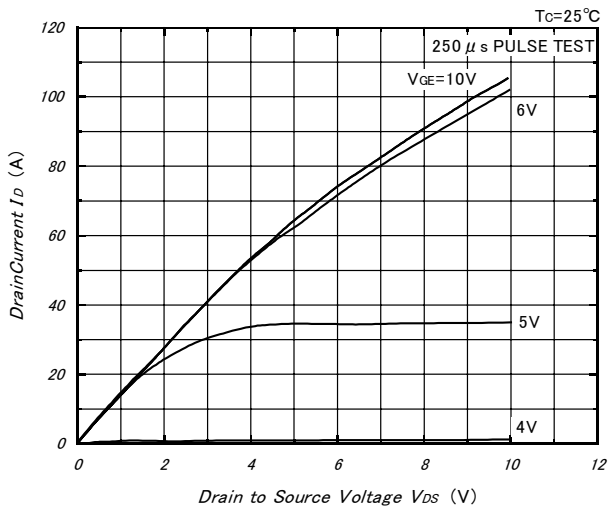

Fig.2- Drain to Source On Voltage vs. Gate to Source Voltage (Typical)

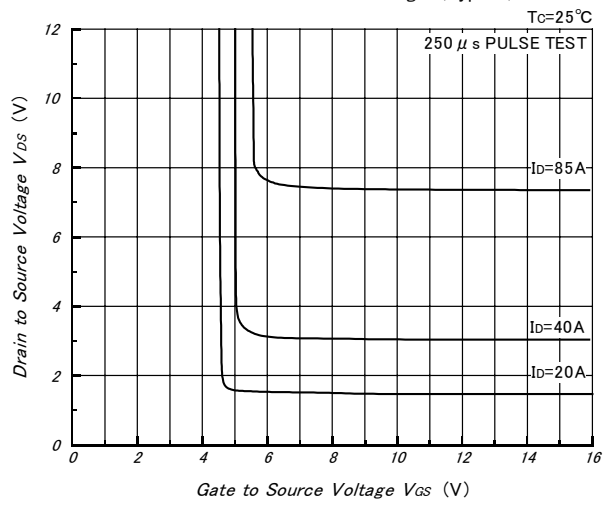

Fig.3- Drain to Source On Voltage vs. Junction Temperature (Typical)

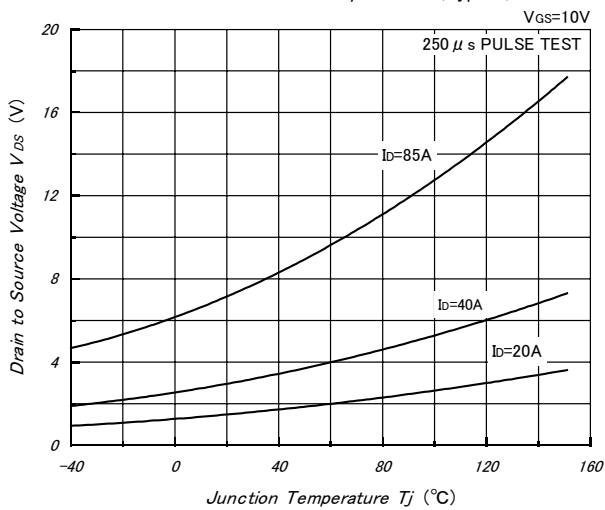

Fig.4- Capacitance vs. Drain to Source Voltage (Typical)

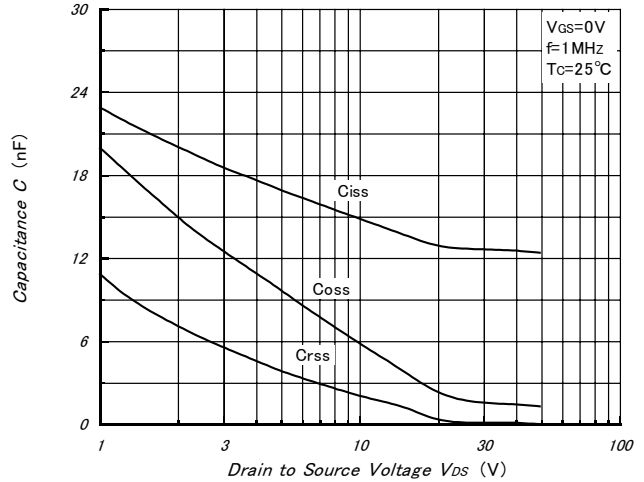

Fig.5- Gate Charge vs. Gate to Source Voltage (Typical)

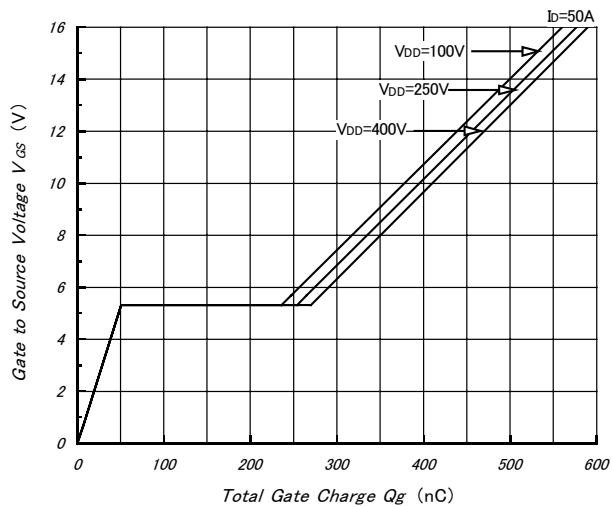

Fig.6- Series Gate Impedance vs. Switching Time (Typical)

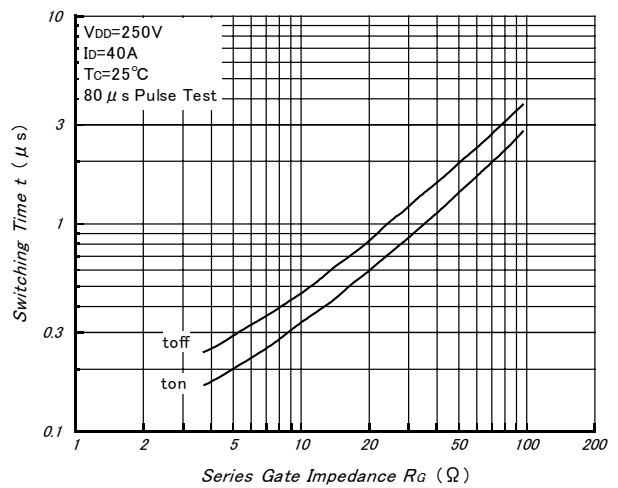

Fig.7- Drain Current vs. Switching Time (Typical)

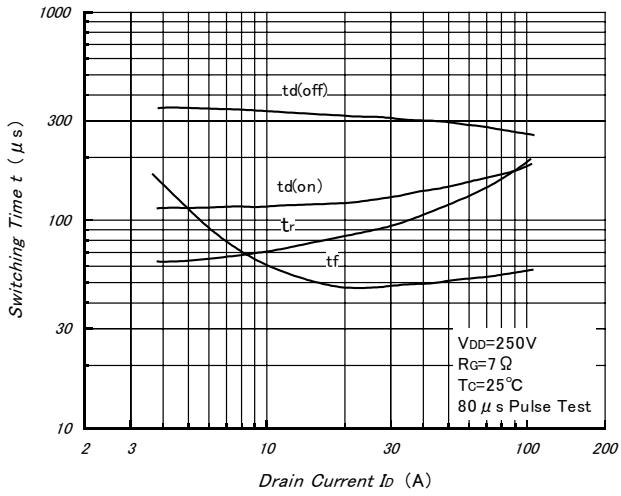

Fig.8- Source to Drain Diode Forward Characteristics (Typical)

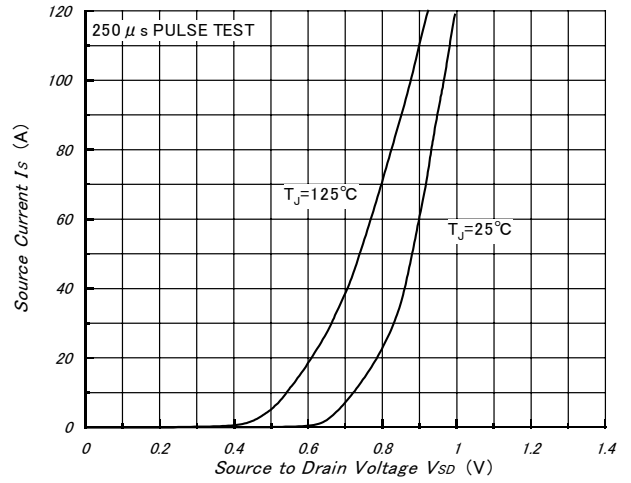

Fig.9- Reverse Recovery Characteristics (Typical)

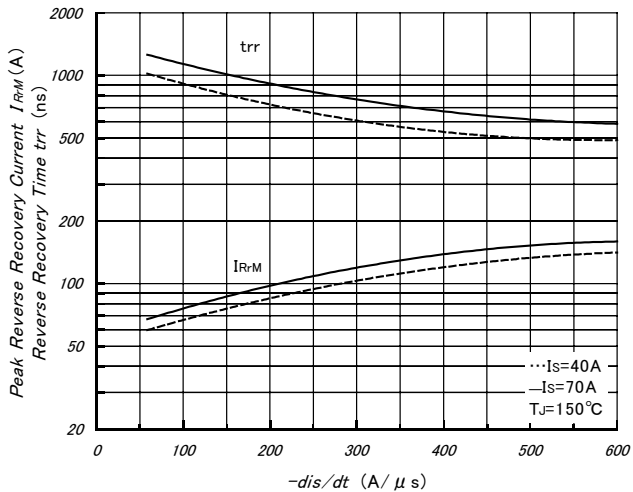

Fig.10- Maximum Safe Operating Area

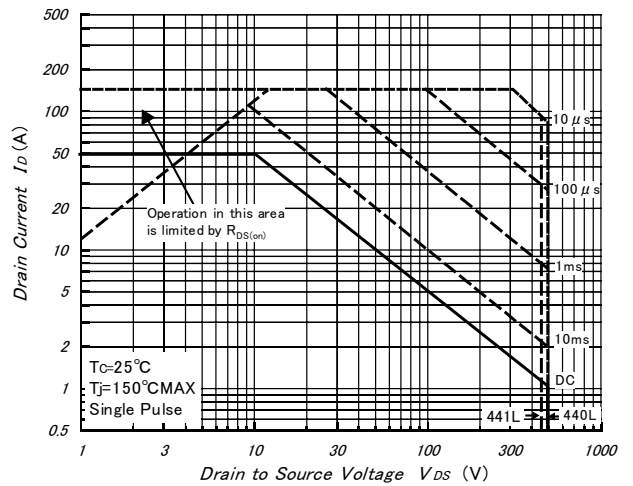

Fig.11- Normalized Transient Thermal Impedance (MOSFET)

