

General Description

The AAT3167 is a low noise, constant frequency charge pump DC/DC converter that uses a tri-mode load switch (1X), fractional (1.5X), and doubling (2X) conversion to maximize efficiency for white LED applications. The AAT3167 is capable of driving five LEDs for a total of 135mA from a 2.7V to 5.5V input. The current sinks may be operated individually or in parallel for driving higher current LEDs. A low external parts count (two 1 μ F flying capacitors and two small 1 μ F capacitors at IN and OUTCP) make this part ideally suited for small, battery-powered applications.

AnalogicTech's AS²Cwire™ (Advanced Simple Serial Control™) serial digital input is used to enable, disable, and set current for each LED with a 16-level logarithmic scale plus four low-current settings down to 115 μ A. For optimized efficiency, low-current settings require only 50 μ A of house-keeping current.

Each output of the AAT3167 is equipped with built-in protection for output short circuit and auto-disable for load short-circuit conditions. Built-in soft-start circuitry prevents excessive inrush current during start-up. A low-current shutdown feature disconnects the load from the input and reduces quiescent current to less than 1 μ A.

The AAT3167 is available in a Pb-free, space-saving, thermally-enhanced, 16-pin 3x4mm TDFN or 16-pin 4x4mm QFN package and is rated over the -40°C to +85°C temperature range.

Features

- V_{IN} Range: 2.7V to 5.5V
- Fully Programmable Current with Single Wire
 - 16-Step Logarithmic Scale
 - 14/18/27mA Max Current
 - Four Low-Current Settings Down to 115 μ A
 - Low I_Q (50 μ A) for Single-Channel, Low-Current Mode
- Tri-Mode 1X, 1.5X, 2X Charge Pump for Maximum Efficiency and V_F Coverage
- Drives Up to Five LEDs
- Individual Main-Sub (4-1) Group Control
- No Inductors, Low Noise Operation
- 1MHz Constant Switching Frequency
- Small Application Circuit
- Built-In Thermal Protection
- Built-In Auto-Disable for Open Circuit
- Automatic Soft Start
- I_Q < 1 μ A in Shutdown
- TDFN34-16 or QFN44-16 Package

Applications

- Color (RGB) Lighting
- Programmable Current Sink
- Transmissive LCD Display
- White LED Backlighting
- White Photo Flash for Digital Still Cameras

Typical Application

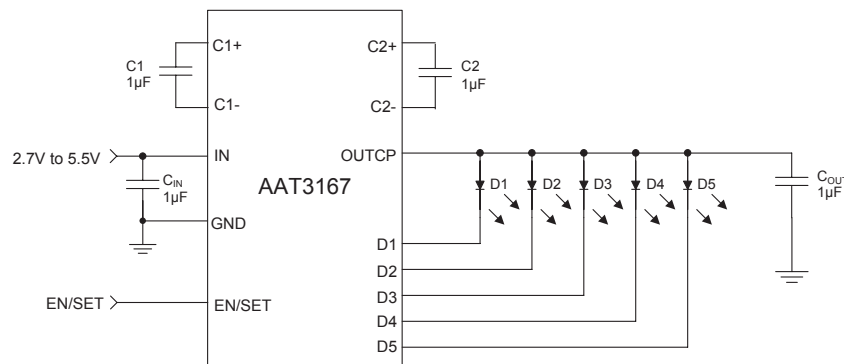

Pin Descriptions

Pin #	Symbol	Function
1, 3	N/C	No connection.
2	EN/SET	AS ² Cwire serial interface control pin.
4	OUTCP	Charge pump output to drive load circuit. Requires 1 μ F capacitor connected between this pin and ground.
5	C2+	Flying capacitor 2 positive terminal. Connect a 1 μ F capacitor between C2+ and C2-.
6	C1+	Flying capacitor 1 positive terminal. Connect a 1 μ F capacitor between C1+ and C1-.
7	C1-	Flying capacitor 1 negative terminal.
8	C2-	Flying capacitor 2 negative terminal.
9, 11	GND	Ground.
10	IN	Input power supply. Requires 1 μ F capacitor connected between this pin and ground.
12	D1	Current sink input #1.
13	D2	Current sink input #2.
14	D3	Current sink input #3.
15	D4	Current sink input #4.
16	D5	Current sink input #5.
EP		Exposed paddle (bottom); connect to ground as closely as possible to the package.

Pin Configuration

TDFN34-16
(Top View)

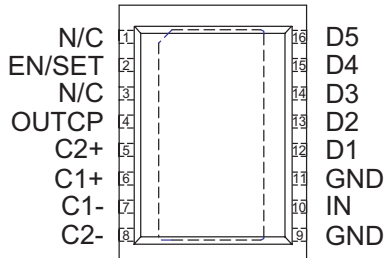

QFN44-16
(Top View)

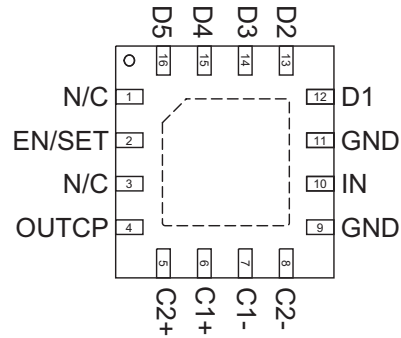

Absolute Maximum Ratings¹

Symbol	Description	Value	Units
V_{IN}	Input Voltage to GND	-0.3 to 6	V
$V_{EN/SET}$	EN/SET Voltage to GND	-0.3 to $V_{IN} + 0.3$	V
I_{OUT}^2	Maximum DC Output Current	150	mA
T_J	Operating Junction Temperature Range	-40 to 150	°C
T_{LEAD}	Maximum Soldering Temperature (at leads, 10 sec)	300	°C

Thermal Information³

Symbol	Description	Value	Units	
P_D	Maximum Power Dissipation	QFN44-16 ⁴	2.0	W
		TDFN34-16 ⁴		
θ_{JA}	Maximum Thermal Resistance	QFN44-16	50	°C/W
		TDFN34-16		

1. Stresses above those listed in Absolute Maximum Ratings may cause permanent damage to the device. Functional operation at conditions other than the operating conditions specified is not implied. Only one Absolute Maximum Rating should be applied at any one time.
2. Based on long-term current density limitation.
3. Mounted on an FR4 board.
4. Derate 20mW/°C above 25°C.

Electrical Characteristics¹

$C_{IN} = C_{OUT} = C_1 = C_2 = 1.0\mu\text{F}$; $T_A = -40^\circ\text{C}$ to $+85^\circ\text{C}$, unless otherwise noted. Typical values are $T_A = 25^\circ\text{C}$, $V_{IN} = 3.6\text{V}$.

Symbol	Description	Conditions	Min	Typ	Max	Units
Input Power Supply						
V_{IN}	Operation Range		2.7		5.5	V
I_{CC}	Operating Current	1X Mode, $3.0 \leq V_{IN} \leq 5.5$, Active, No Load Current, High Current Mode		0.3		mA
		1.5X Mode, $3.0 \leq V_{IN} \leq 5.5$, Active, No Load Current, High Current Mode		1		
		2X Mode, $3.0 \leq V_{IN} \leq 5.5$, Active, No Load Current, High Current Mode		1		
		1X Mode, $3.0 \leq V_{IN} \leq 5.5$, D5 Active, $I_{DS} = 100\mu\text{A}$, Low Current Mode			50	μA
I_{SHDN}	Shutdown Current	$V_{EN/SET} = 0\text{V}$			1	μA
I_{DX}	High Current Accuracy	$I_{SET} = 18\text{mA}$, $T_A = 25^\circ\text{C}$	-10		10	%
	Low Current Accuracy	$I_{SET} = 400\mu\text{A}$, $T_A = 25^\circ\text{C}$		15		%
$I_{(D-Match)}$	Current Matching ²	$V_F:D1:D5 = 3.6\text{V}$		0.5	1	%
V_{TH}	1X to 1.5X or 1.5X to 2X Transition Threshold at Any I_{SINK} Pin			150		mV
Charge Pump Section						
T_{SS}	Soft-Start Time			100		μs
F_{CLK}	Clock Frequency			1000		kHz
EN/SET						
$V_{EN(L)}$	Enable Threshold Low	$V_{IN} = 2.7\text{V}$			0.4	V
$V_{EN(H)}$	Enable Threshold High	$V_{IN} = 5.5\text{V}$	1.4			V
$T_{EN/SET LO}$	EN/SET Low Time		0.3		75	μs
$T_{EN/SET HI}$	Minimum EN/SET High Time			50		ns
$T_{EN/SET HI MAX}$	Maximum EN/SET High Time				75	μs
T_{OFF}	EN/SET Off Timeout				500	μs
T_{LAT}	EN/SET Latch Timeout				500	μs
$I_{EN/SET}$	EN/SET Input Leakage		-1		1	μA

- The AAT3167 is guaranteed to meet performance specifications over the -40°C to $+85^\circ\text{C}$ operating temperature range and is assured by design, characterization, and correlation with statistical process controls.
- Current matching is defined as the deviation of any sink current from the average of all active channels.

Typical Characteristics

$C_{IN} = C_{OUT} = C_1 = C_2 = 1.0\mu F$; $T_A = 25^\circ C$, $V_{IN} = 3.6V$, unless otherwise noted.

Efficiency vs. Supply Voltage

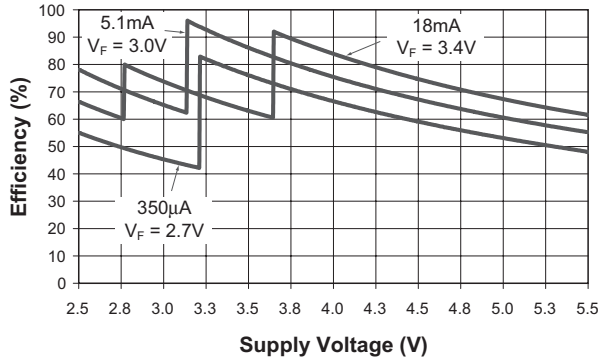

Turn-On to 1X Mode
($V_{IN} = 4.2V$; 18mA Load)

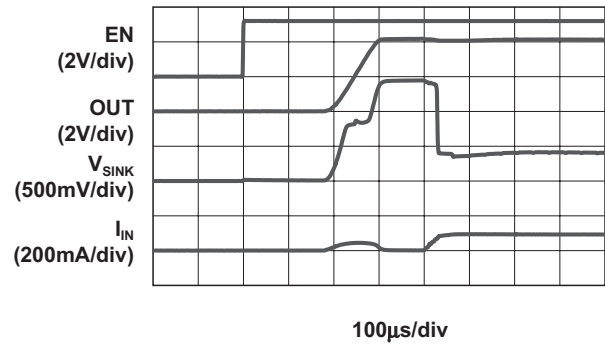

Turn-On to 1.5X Mode
($V_{IN} = 3.5V$; 18mA Load)

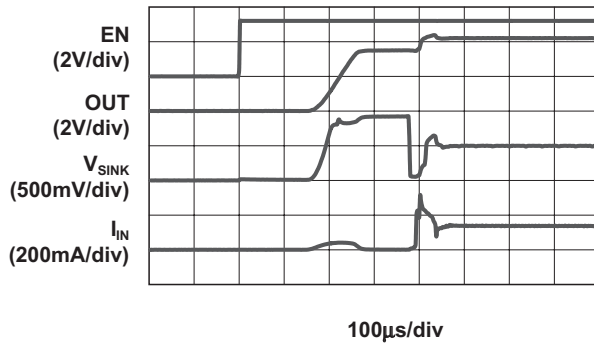

Turn-On to 2X Mode
($V_{IN} = 2.8V$; 18mA Load)

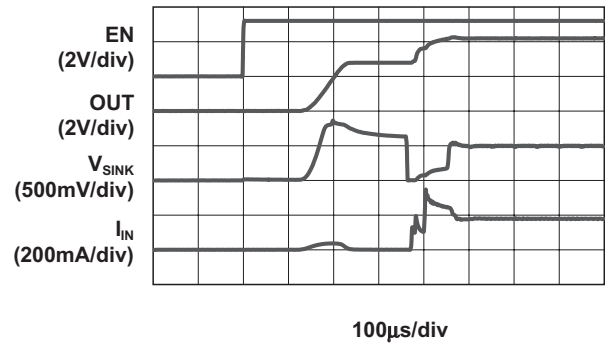

Turn-Off from 1.5X Mode
($V_{IN} = 3.5V$; 18mA Load)

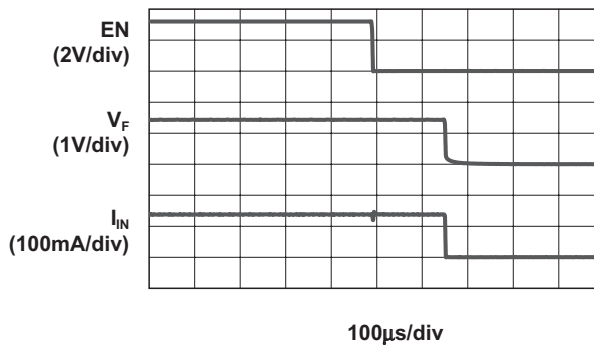

Current Matching vs. Temperature

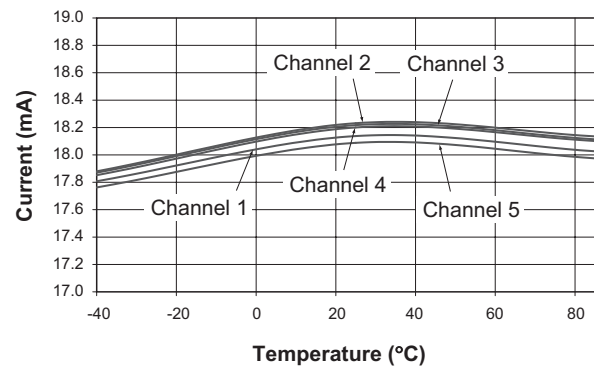

Typical Characteristics

$C_{IN} = C_{OUT} = C_1 = C_2 = 1.0\mu\text{F}$; $T_A = 25^\circ\text{C}$, $V_{IN} = 3.6\text{V}$, unless otherwise noted.

Load Characteristics
($V_{IN} = 3.9\text{V}$; 1.5X Mode; 18mA Load)

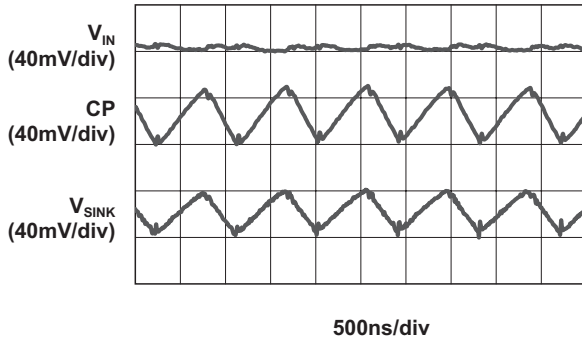

Load Characteristics
($V_{IN} = 2.9\text{V}$; 2X Mode; 18mA Load)

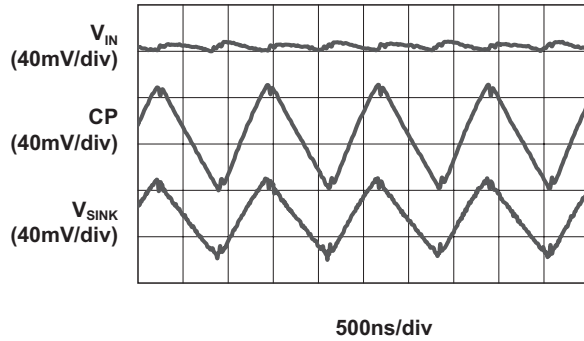

Load Characteristics
($V_{IN} = 4.2\text{V}$; 1.5X Mode; 27mA Load)

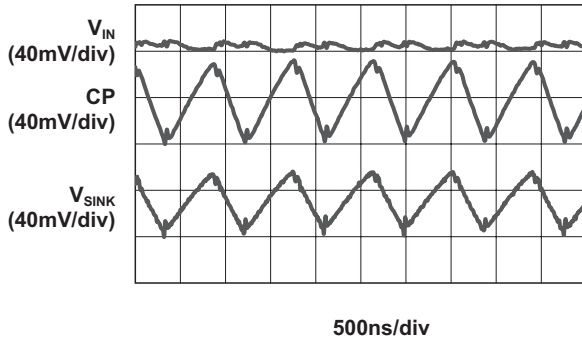

Load Characteristics
($V_{IN} = 3.3\text{V}$; 2X Mode; 27mA Load)

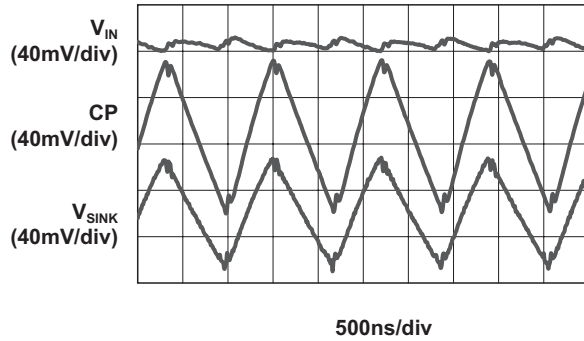

Input Ripple vs. Input Voltage

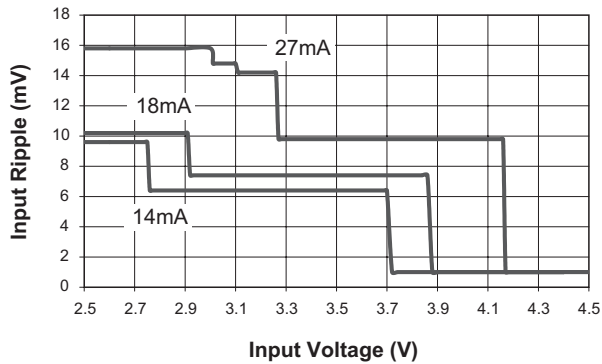

Typical Characteristics

$C_{IN} = C_{OUT} = C_1 = C_2 = 1.0\mu F$; $T_A = 25^\circ C$, $V_{IN} = 3.6V$, unless otherwise noted.

T_{LAT} vs. V_{IN}

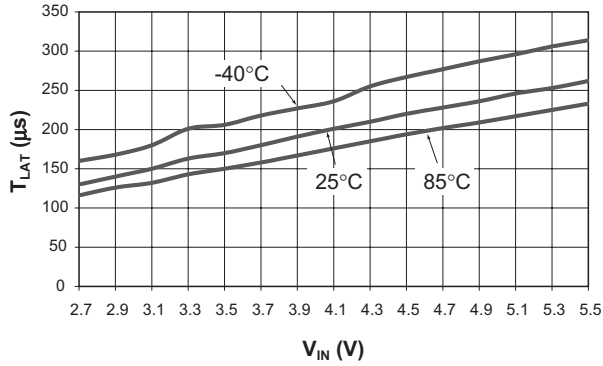

T_{OFF} vs. V_{IN}

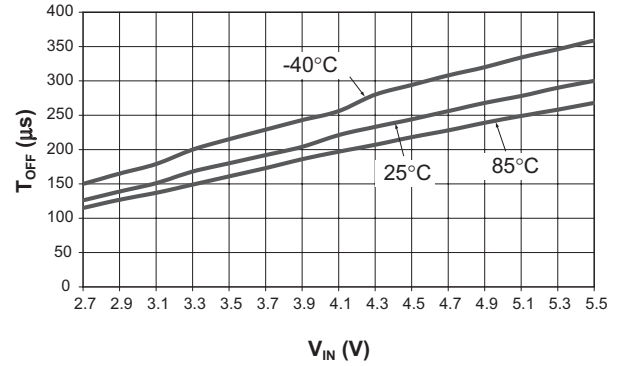

V_{IH} vs. V_{IN}

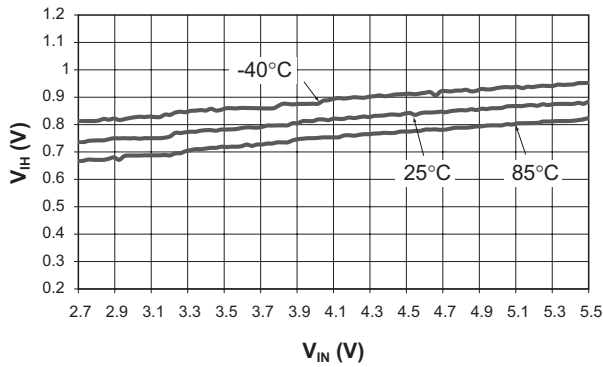

V_{IL} vs. V_{IN}

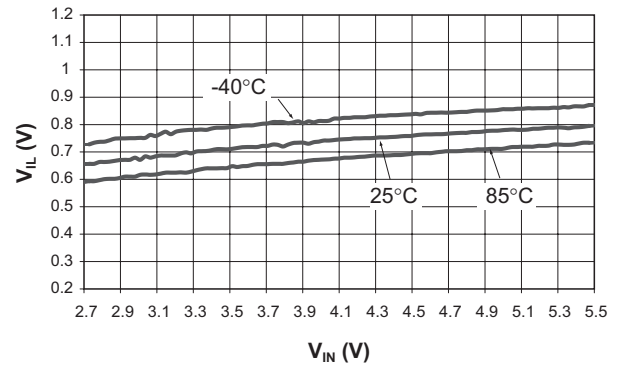

Functional Block Diagram

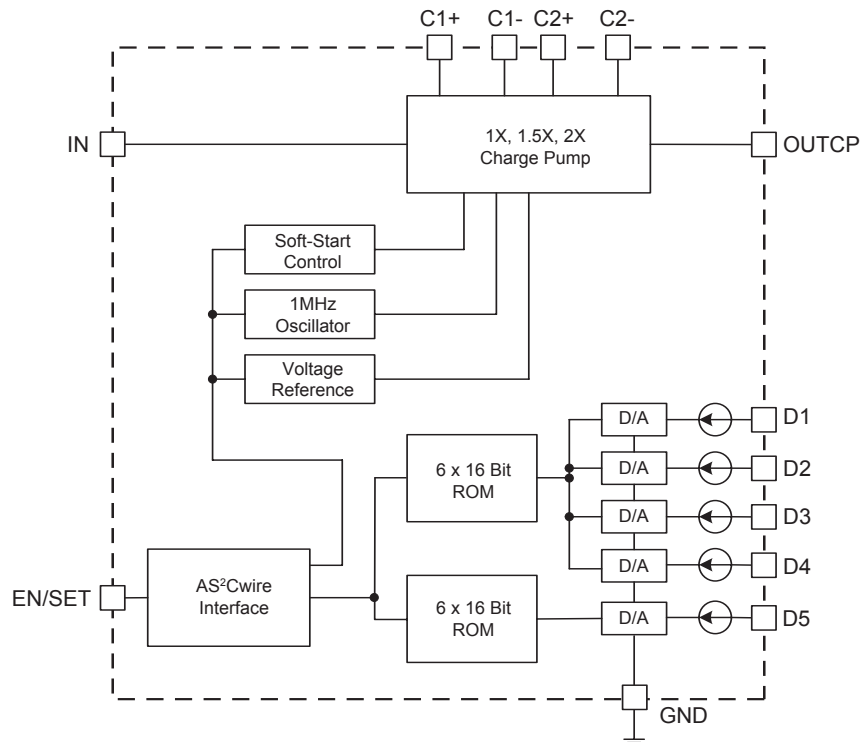

Functional Description

The AAT3167 is a tri-mode load switch (1X) and high efficiency (1.5X or 2X) charge pump device intended for white LED backlight applications. To maximize power conversion efficiency, an internal sensing circuit monitors the voltage required on each constant current sink input and sets the load switch and charge pump modes based on the input battery voltage and the current sink input voltage. As the battery discharges over time, the AAT3167 charge pump is enabled when any of the five current sink inputs near dropout. The charge pump initially starts in 1.5X mode. If the charge pump output droops enough for any current source output to become close to dropout, the charge pump will automatically transition to 2X mode. The AAT3167 requires only four external components: two 1 μ F ceramic capacitors for the charge pump flying capacitors (C1 and C2), one 1 μ F ceramic input

capacitor (C_{IN}), and one 0.33 μ F to 1 μ F ceramic charge pump output capacitor (C_{OUT}).

The five constant current sink inputs (D1 to D5) can drive five individual LEDs with a maximum current of 27mA nominal each. Unused sink inputs should be connected to OUTCP, otherwise the part will operate only in 2X charge pump mode. The AS²Cwire serial interface enables the AAT3167 and sets the current sink magnitudes. AS²Cwire addressing allows independent control of two groups of current sink input: D1~D4 and D5.

Constant Current Output Level Settings

The constant current sink levels for D1 to D5 are set via the serial interface according to a logarithmic scale, where each code is approximately 1.8dB lower than the previous code. In this manner, LED brightness appears linear with each increasing code count. Because the inputs D1 to D5 are true

independent constant current sinks, the voltage observed on any single given input will be determined by the actual forward voltage (V_F) for the LED being driven.

Since the input current sinks of the AAT3167 are programmable, no PWM (pulse width modulation) or additional control circuitry is needed to control LED brightness. This feature greatly reduces the burden on a microcontroller or system IC to manage LED or display brightness, allowing the user to "set it and forget it." With its high-speed serial interface (1MHz data rate), the input sink current of the AAT3167 can be changed successively to brighten or dim LEDs in smooth transitions (e.g., to fade-out) or in abrupt steps, giving the user complete programmability and real-time control of LED brightness.

The 16 individual current level settings are each approximately 2dB apart (see Table 1); the spacing at higher settings is less than 2dB, whereas at lower settings it is greater. Code 1 is full scale; Code 15 is full scale attenuated by approximately 30dB; and Code 16 is reserved as a "no current" setting.

Data	27mA Max I_{OUT} (mA)	18mA Max I_{OUT} (mA)	14mA Max I_{OUT} (mA)
1	27	18	14
2	22	15	11
3	18	12	8.8
4	14	10	7.1
5	12	7.9	6.0
6	10	6.3	4.8
7	8	5.1	3.8
8	6.2	4.1	3.1
9	5.2	3.5	2.6
10	4.3	2.9	2.1
11	3.3	2.2	1.7
12	2.9	1.9	1.4
13	2.4	1.6	1.2
14	1.9	1.3	1.0
15	1.4	1.0	0.7
16	0	0	0

Table 1: Current Level Settings.

AS²Cwire Serial Interface

The current sink input magnitude on AAT3167 is controlled by AnalogicTech's AS²Cwire serial digital input. AS²Cwire adds addressing capability for multiple data registers over the Simple Serial Control™ (S²Cwire™) interface, which is only capable of controlling a single register. The AAT3167 has four registers: Bank1, Bank2, Max Current, and Low Current.

Three addresses are used to control the two registers. Address 0 addresses both registers simultaneously to allow the loading of both registers with the same data using a single write protocol. Address 1 addresses Register 1 for D1 to D4 current level settings. Address 2 addresses Register 2 for D5 current level settings.

AS²Cwire relies on the number of rising edges of the EN/SET pin to address and load the registers. AS²Cwire latches data or address after the EN/SET pin has been held high for time T_{LAT} . Address or data is differentiated by the number of EN/SET rising edges. Since the data registers are 4 bits each, the differentiating number of pulses is 2^4 or 16, so that Address 0 is signified by 17 rising edges, Address 1 by 18 rising edges, and Address 2 by 19 rising edges. Data is set to any number of rising edges between 1 and including 16. A typical write protocol is a burst of EN/SET rising edges signifying a particular address, followed by a pause with EN/SET held high for the T_{LAT} timeout period, a burst of rising edges signifying data, and a T_{LAT} timeout for the data registers. Once an address is set, then multiple writes consisting of data only (without address) to the corresponding data register are allowed. Address 0 is the default address on the first rising edge after the AAT3167 has been disabled. If data is presented on the first rising edge with no prior address, both data registers are simultaneously loaded.

The maximum current level is determined by the value set in Register 3, the Max Current register. Three scales are available for high operating currents with maximum current levels of 27mA, 18mA, or 14mA. Each scale maintains approximately 1.8dB steps between settings. A separate mode is available for ultra-low LED current operation. When

the Max Current register (Register 3) is set to the Low Current setting, the Low Current register (Register 4) must be programmed. The two most significant bits of the Low Current register control whether or not a given bank of current sinks is enabled. The least two significant bits of the Low Current register set the current level for both banks. For low-current settings, the charge pump may be enabled if required by the battery voltage and LED forward voltage conditions, and 1X mode quiescent current is approximately 100µA for multiple channels or 50µA for Channel 5 operation only. Both banks of current sinks must be in the same high- or low-current mode of operation.

When EN/SET is held low for an amount of time greater than T_{OFF} , the AAT3167 enters shutdown mode and draws less than 1µA from V_{IN} . Data and Address registers are reset to 0 during shutdown.

AS²Cwire Serial Interface Addressing

Address	EN/SET Rising Edges	Data Register AAT3167
0	17	1&2: D1~D5 Current
1	18	1: D1~D4 Current
2	19	2: D5 Current
3	20	3: Max Current
4	21	4: Low Current

Data	Max Current
1	18mA
2	27mA
3	14mA
4	Low Current (see Low Current Register for values)

Low Current Register (Address 4)

Data	Main Low Current On	Sub Low Current On	Current
1	No	No	
2	No	No	
3	No	No	
4	No	No	
5	No	Yes	115µA
6	No	Yes	175µA
7	No	Yes	280µA
8	No	Yes	400µA
9	Yes	No	115µA
10	Yes	No	175µA
11	Yes	No	280µA
12	Yes	No	400µA
13	Yes	Yes	115µA
14	Yes	Yes	175µA
15	Yes	Yes	280µA
16	Yes	Yes	400µA

Auto-Disable Feature

The AAT3167 is equipped with an auto-disable feature for each LED channel. After the IC is enabled and started up, a test current of 120µA (typical) is forced through each sink channel. The channel will be disabled if the voltage of that particular SINK pin does not drop to a certain threshold. This feature is very convenient for disabling an unused channel or during an LED fail-short event.

Thermal Protection

The AAT3167 has a built-in thermal protection circuit that will shut down the charge pump if the die temperature rises above the thermal limit, as would be the case during a short circuit of the OUTCP pin.

AS²Cwire Serial Interface Timing

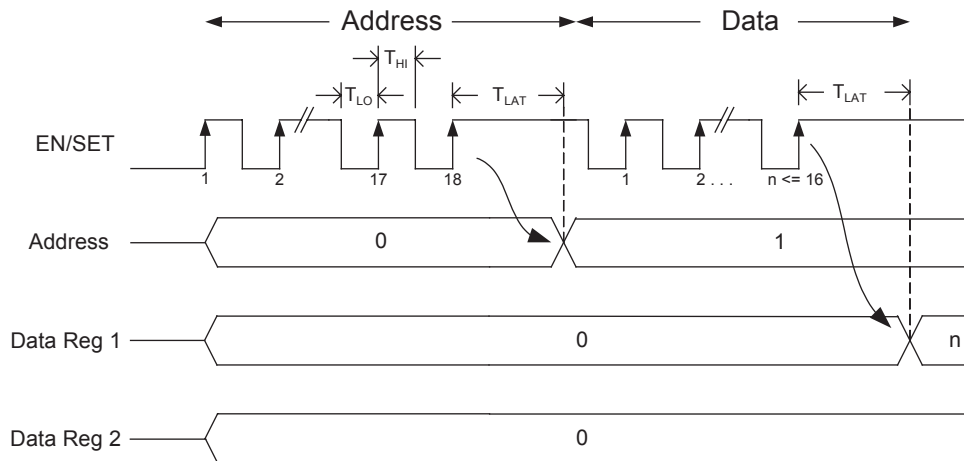

Applications Information

LED Selection

Although the AAT3167 is designed for driving white LEDs, the device also can be used to drive most types of LEDs with forward voltage specifications ranging from 2.0V to 4.7V. LED applications may include main and sub-LCD display backlighting, camera photo-flash applications, color (RGB) LEDs, infrared diodes for remotes, and other loads benefiting from a controlled output current generated from a varying input voltage. Since the D1 to D5 input current sinks are matched with negligible voltage dependence, the LED brightness will be matched regardless of the specific LED forward voltage (V_F) levels.

In some instances (e.g., in high-luminous-output applications such as photo flash), it may be necessary to drive high- V_F type LEDs. The low-dropout current sinks in the AAT3167 make it capable of driving LEDs with forward voltages as high as 4.7V at full current from an input supply as low as 3.0V. Outputs can be paralleled to drive high-current LEDs without complication.

Device Switching Noise Performance

The AAT3167 operates at a fixed frequency of approximately 1MHz to control noise and limit harmonics that can interfere with the RF operation of cellular telephone handsets or other communication devices. Back-injected noise appearing on the input pin of the charge pump is 20mV peak-to-peak, typically ten times less than inductor-based DC/DC boost converter white LED backlight solutions. The AAT3167 soft-start feature prevents noise transient effects associated with inrush currents during start-up of the charge pump circuit.

Capacitor Selection

Careful selection of the four external capacitors (C_{IN} , C1, C2, C_{OUT}) is important because they will affect turn-on time, output ripple, and transient performance. Optimum performance will be obtained when low equivalent series resistance (ESR) (<100m Ω) ceramic capacitors are used. A value of 1 μ F for all four capacitors is a good starting point when choosing capacitors. If the LED current sources are programmed only for light current levels, then the capacitor size may be decreased.

Capacitor Characteristics

Ceramic composition capacitors are highly recommended over all other types of capacitors for use with the AAT3167. Ceramic capacitors offer many advantages over their tantalum and aluminum electrolytic counterparts. A ceramic capacitor typically has very low ESR, is lowest cost, has a smaller PCB footprint, and is non-polarized. Low-ESR ceramic capacitors help maximize charge pump transient response. Since ceramic capacitors are non-polarized, they are not prone to incorrect connection damage.

Equivalent Series Resistance

ESR is an important characteristic to consider when selecting a capacitor. ESR is a resistance internal to a capacitor that is caused by the leads, internal connections, size or area, material composition, and ambient temperature. Capacitor ESR is typically measured in milliohms for ceramic capacitors and can range to more than several ohms for tantalum or aluminum electrolytic capacitors.

Ceramic Capacitor Materials

Ceramic capacitors less than $0.1\mu\text{F}$ are typically made from NPO or C0G materials. NPO and C0G materials generally have tight tolerance and are very stable over temperature. Larger capacitor values are usually composed of X7R, X5R, Z5U, or Y5V dielectric materials. Large ceramic capacitors (i.e., greater than $2.2\mu\text{F}$) are often available in low-cost Y5V and Z5U dielectrics, but capacitors greater than $1\mu\text{F}$ are not typically required for AAT3167 applications.

Capacitor area is another contributor to ESR. Capacitors that are physically large will have a lower ESR when compared to an equivalent material smaller capacitor. These larger devices can improve circuit transient response when compared to an equal value capacitor in a smaller package size.

Ordering Information

Package	Marking ¹	Part Number (Tape and Reel) ²
TDFN34-16		
QFN44-16	PWXY	AAT3167ISN-T1



All AnalogicTech products are offered in Pb-free packaging. The term "Pb-free" means semiconductor products that are in compliance with current RoHS standards, including the requirement that lead not exceed 0.1% by weight in homogeneous materials. For more information, please visit our website at <http://www.analogictech.com/pbfree>.

Package Information

TDFN34-16

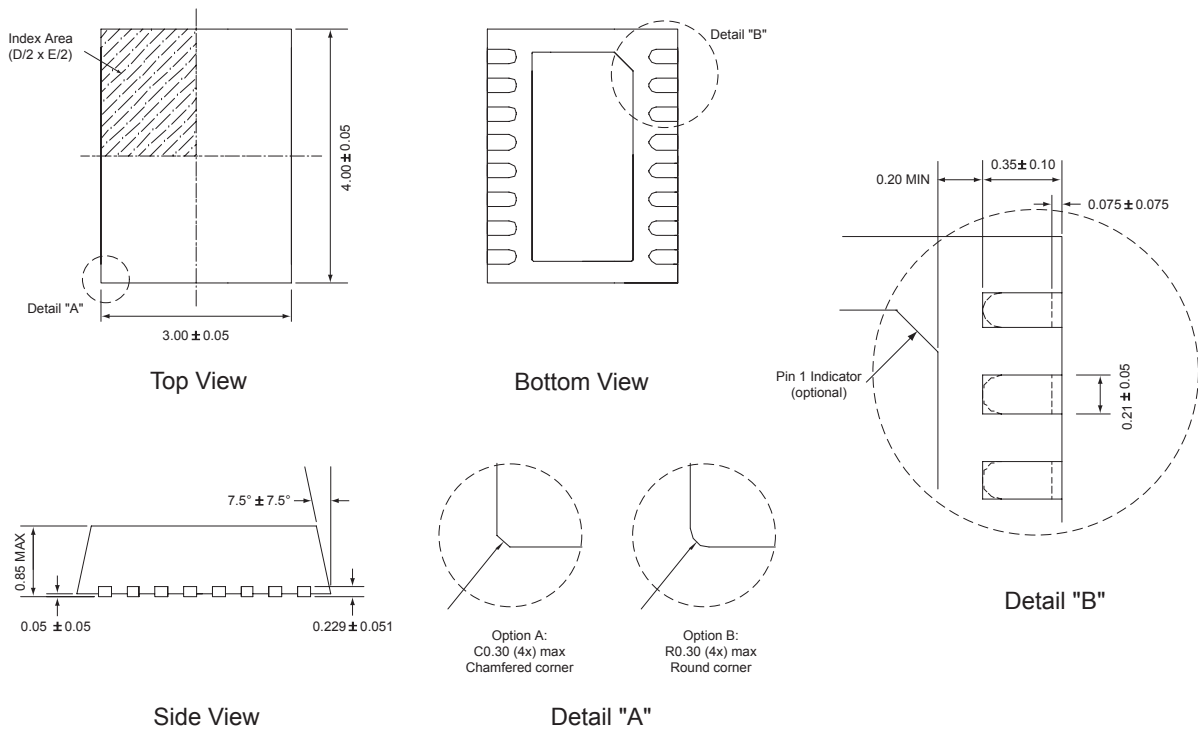

All dimensions in millimeters.

1. XYY = assembly and date code.
2. Sample stock is generally held on part numbers listed in **BOLD**.

QFN44-16



All dimensions in millimeters.

© Advanced Analogic Technologies, Inc.

AnalogicTech cannot assume responsibility for use of any circuitry other than circuitry entirely embodied in an AnalogicTech product. No circuit patent licenses, copyrights, mask work rights, or other intellectual property rights are implied. AnalogicTech reserves the right to make changes to their products or specifications or to discontinue any product or service without notice. Customers are advised to obtain the latest version of relevant information to verify, before placing orders, that information being relied on is current and complete. All products are sold subject to the terms and conditions of sale supplied at the time of order acknowledgement, including those pertaining to warranty, patent infringement, and limitation of liability. AnalogicTech warrants performance of its semiconductor products to the specifications applicable at the time of sale in accordance with AnalogicTech's standard warranty. Testing and other quality control techniques are utilized to the extent AnalogicTech deems necessary to support this warranty. Specific testing of all parameters of each device is not necessarily performed.

AnalogicTech and the AnalogicTech logo are trademarks of Advanced Analogic Technologies Incorporated. All other brand and product names appearing in this document are registered trademarks or trademarks of their respective holders.

Advanced Analogic Technologies, Inc.
 830 E. Arques Avenue, Sunnyvale, CA 94085
 Phone (408) 737-4600
 Fax (408) 737-4611