

---

Approved by:

Checked by:

Issued by:

# ***SPECIFICATION***

**PRODUCT:**            **SAW FILTER**

---

**MODEL:**             **HDF480A TO-39**

---

**SHOULDER**  
好达电子

**SHOULDER ELECTRONICS LIMITED**

## 1. SCOPE

This specification shall cover the characteristics of SAW filter with 480MHz used for DBS receiver.

## 2. ELECTRICAL SPECIFICATION

DC Voltage VDC	10V
AC Voltage Vpp	10V50Hz/60Hz
Operation temperature	-20 to +60
Storage temperature	-45 to +85
RF Power Dissipation	0dBm

### Electronic Characteristics

#### 2-1. Typical frequency response

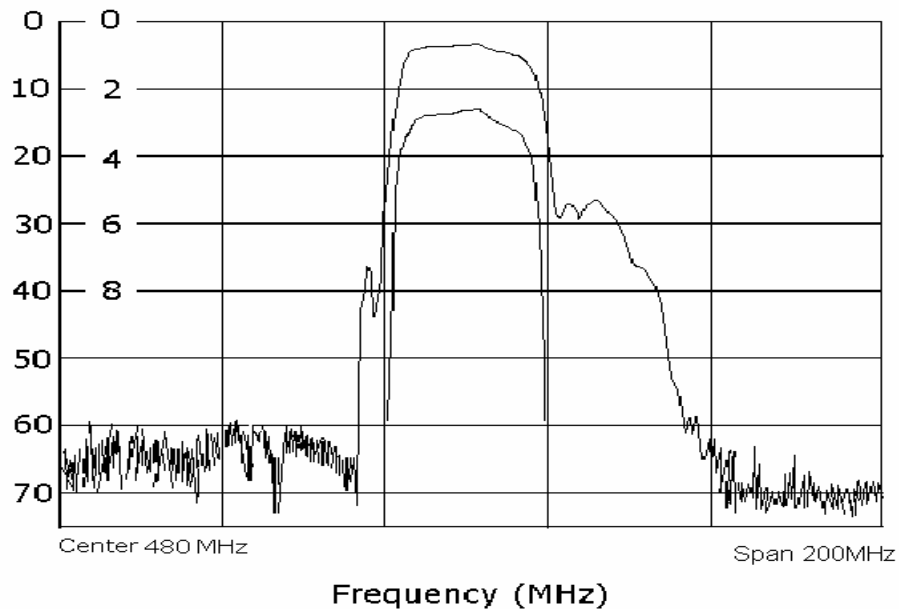

#### 2-2. Electrical characteristics

Part number	F480A	Unit
Center frequency fo	480.000	MHz
Insertion Loss: Fo: Fo ± 39.8~45.8MHz fo ± 45.8~100.0MHz	4.5max 45.0min 50.0min	dB
Passband width(-3dB)	9.0 type	MHz
Ripple(Fo ± 4.0MHz)	2.0max	dB
Group delay	100	ns
Group delay ripple	100	ns
Input/Output impedance	50//0	//pF

(Note: Operating temperature Range:-20 to +60 )

### 3. TEST CIRCUIT

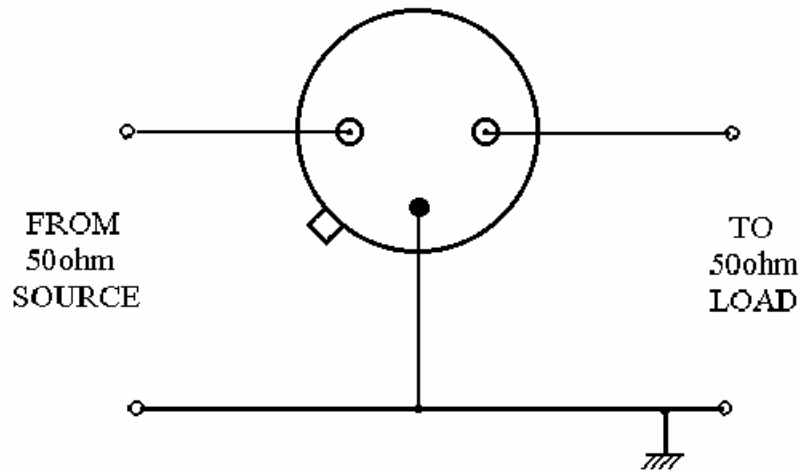

### 4. DIMENSION

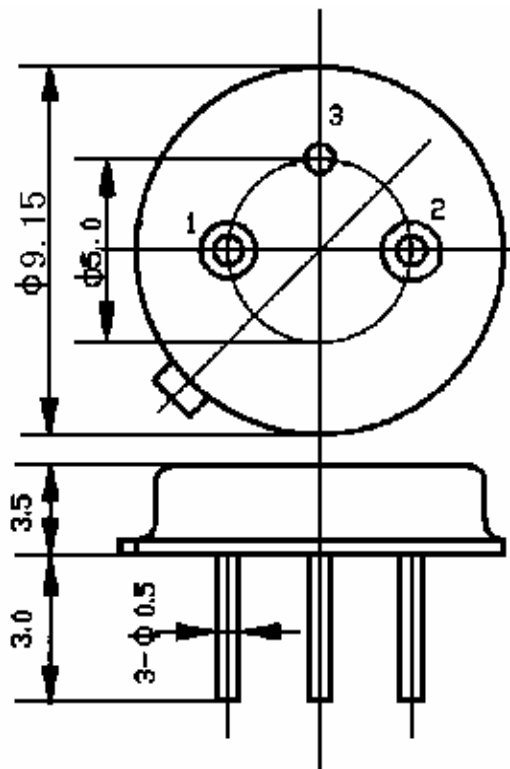

### 5. ENVIRONMENTAL CHARACTERISTICS

#### 5-1 High temperature exposure

Subject the device to +85 for 16 hours. Then release the filter into the room conditions for 24 hours prior to the measurement. It shall fulfill the specifications in table 1.

#### 5-2 Low temperature exposure

Subject the device to -20 for 16 hours. Then release the device into the room conditions for 24 hours prior to the measurement. It shall fulfill the specifications in table 1.

### 5-3 Temperature cycling

Subject the device to a low temperature of -40 for 30 minutes. Following by a high temperature of +80 for 30 Minutes. Then release the device into the room conditions for 24 hours prior to the measurement. It shall meet the specifications in table 1.

### 5-4 Resistance to solder heat

Dip the device terminals no closer than 1.5mm into the solder bath at  $260 \pm 10$  for  $10 \pm 1$  sec. Then release the device into the room conditions for 4 hours. The device shall meet the specifications in table 1.

### 5-5 Solderability

Subject the device terminals into the solder bath at  $245 \pm 5$  for 5s, More than 95% area of the terminals must be covered with new solder. It shall meet the specifications in table 1.

### 5-6 Mechanical shock

Drop the device randomly onto the concrete floor from the height of 1m 3 times. the device shall fulfill the specifications in table 1.

### 5-7 Vibration

Subject the device to the vibration for 1 hour each in x,y and z axes with the amplitude of 1.5 mm at 10 to 55 Hz. The device shall fulfill the specifications in table 1.

### 5-8 Lead fatigue

#### 5-8-1 Pulling test

Weight along with the direction of lead without an shock 1kg. The device shall satisfy all the initial Characteristics.

#### 5-8-2 Bending test

Lead shall be subject to withstand against 90 bending with 450g weight in the direction of thickness. This operation shall be done toward both direction. The device shall show no evidence of damage and shall satisfy all the initial electrical characteristics.

## 6. REMARK

### 6.1 Static voltage

Static voltage between signal load & ground may cause deterioration & destruction of the component. Please avoid static voltage.

### 6.2 Ultrasonic cleaning

Ultrasonic vibration may cause deterioration & destruction of the component. Please avoid ultrasonic cleaning

### 6.3 Soldering

Only leads of component may be soldered. Please avoid soldering another part of component.