

FEATURES

- 28mm (1-1/8 Inch) Diameter Side-on
- 300 to 650nm Spectral Response
- Low Dark Current Visible Range Photocathode



GENERAL

Parameter	Description/Value	Unit
Spectral Response	300 to 650	nm
Wavelength of Maximum Response	400	nm
Photo-cathode	Material	Sb-Cs
	Minimum Useful Size	8 × 24
Window Material	Borosilicate glass	—
Dynode	Structure	Circular-cage
	Number of Stages	9
Direct Interelectrode Capacitances	Anode to Last Dynode	4
	Anode to All Other Electrodes	6
Base	JEDEC No. B11-88	—
Suitable Socket	E678-11A	—

Figure 1: Typical Spectral Response

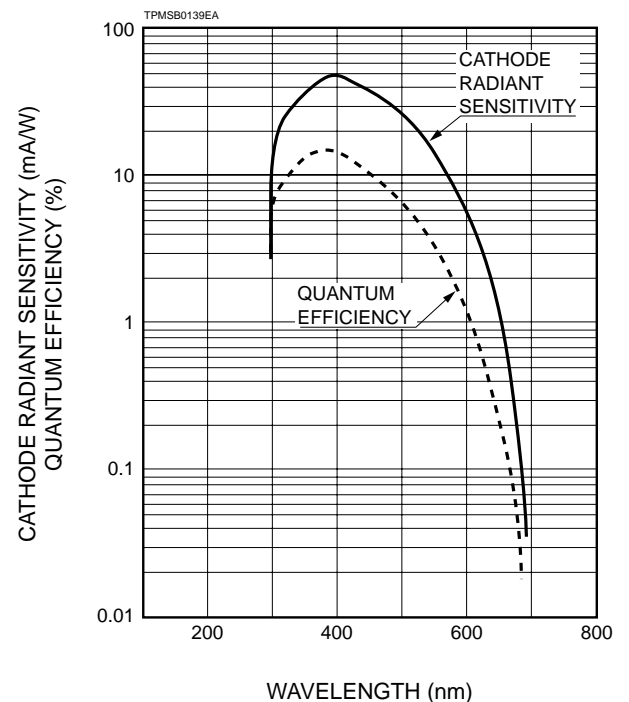

PHOTOMULTIPLIER TUBE 1P21

MAXIMUM RATINGS (Absolute Maximum Values)

Parameter	Value	Unit	
Supply Voltage	Between Anode and Cathode	1250	Vdc
	Between Anode and Last Dynode	250	Vdc
Average Anode Current	0.1	mA	
Ambient Temperature	-80 to +50	°C	

CHARACTERISTICS (at 25°C)

Parameter	Min.	Typ.	Max.	Unit	
Anode Sensitivity	Luminous (2856K)	50	250	—	A/lm
	Radiant at 400nm	—	3.0×10^5	—	A/W
Cathode Sensitivity	Luminous (2856K)	25	40	—	μA/lm
	Radiant at 400nm	—	48	—	mA/W
	Quantum Efficiency	—	13 at 350nm	—	%
Gain	—	6.25×10^6	—	—	
Anode Dark Current (after 30 minute)	—	1	5	nA	
Time Response	Anode Pulse Rise Time	—	2.2	—	ns
	Electron Transit Time	—	22	—	ns

VOLTAGE DISTRIBUTION RATIO AND SUPPLY VOLTAGE

Electrodes	K	Dy1	Dy2	Dy3	Dy4	Dy5	Dy6	Dy7	Dy8	Dy9	P
Ratio	1	1	1	1	1	1	1	1	1	1	1

Supply Voltage: 1000Vdc, K: Cathode, Dy: Dynode, P: Anode

Figure 2: Typical Gain Characteristics

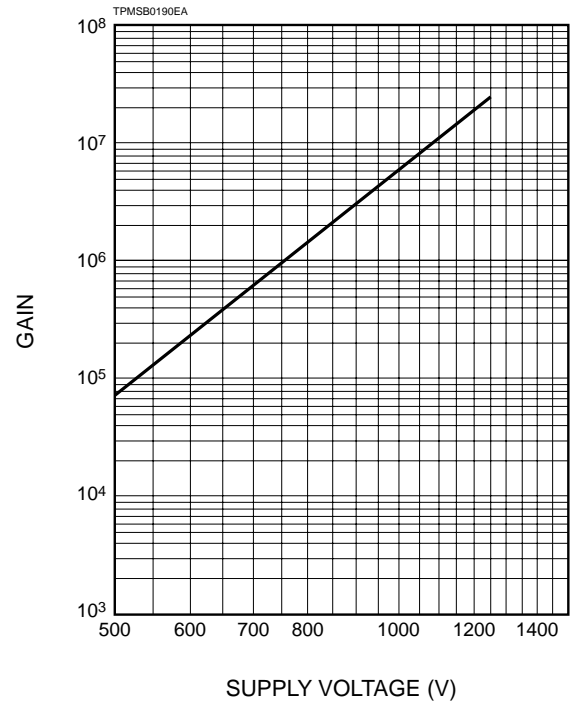
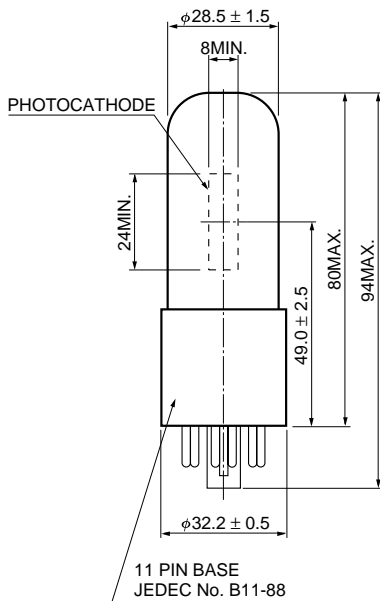
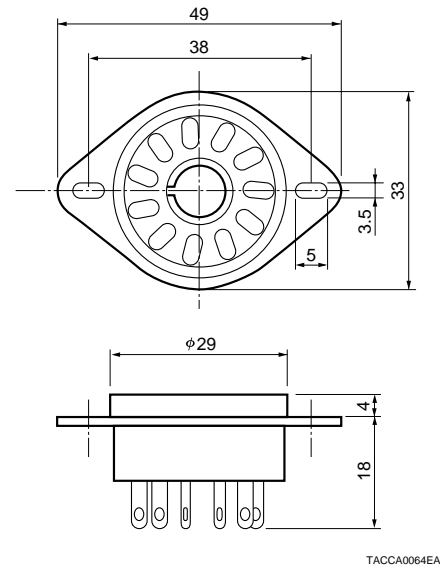

Figure 3: Dimensional Outline and Basing Diagram (Unit: mm)



TPMSA0001EA

Socket (Option) (E678-11A)



TACCA0064EA

HAMAMATSU

HAMAMATSU PHOTONICS K.K., Electron Tube Center

314-5, Shimokanzo, Toyooka-village, Iwata-gun, Shizuoka-ken, 438-0193, Japan, Telephone: (81)539/62-5248, Fax: (81)539/62-2205

U.S.A.: Hamamatsu Corporation: 360 Foothill Road, P. O. Box 6910, Bridgewater, N.J. 08807-0910, U.S.A., Telephone: (1)908-231-0960, Fax: (1)908-231-1218

Germany: Hamamatsu Photonics Deutschland GmbH: Arzbergerstr. 10, D-82211 Herrsching am Ammersee, Germany, Telephone: (49)8152-375-0, Fax: (49)8152-2658

France: Hamamatsu Photonics France S.A.R.L.: 8, Rue du Saule Trapu, Parc du Moulin de Massy, 91882 Massy Cedex, France, Telephone: (33)1 69 53 71 00, Fax: (33)1 69 53 71 10

United Kingdom: Hamamatsu Photonics UK Limited: Lough Point, 2 Gladbeck Way, Windmill Hill, Enfield, Middlesex EN2 7JA, United Kingdom, Telephone: (44)181-367-3560, Fax: (44)181-367-6384

North Europe: Hamamatsu Photonics Norden AB: Smidesvägen 12, SE-171-41 SOLNA, Sweden, Telephone: (46)8-509-031-00, Fax: (46)8-509-031-01

Italy: Hamamatsu Photonics Italia: S.R.L.: Strada della Moia, 1/E, 20020 Arese, (Milano), Italy, Telephone: (39)02-935 81 733, Fax: (39)02-935 81 741