

THIS DOCUMENT AND THE DATA DISCLOSED HEREIN OR HEREWITH IS NOT TO BE REPRODUCED, USED, OR DISCLOSED IN WHOLE OR IN PART TO ANYONE WITHOUT PERMISSION OF VICOR CORP.

REV.	DESCRIPTION	DATE	APPROVED
#1	DRAWN FOR DEVELOPMENT	AK 5/03/01	GCK
#2	REVSD PER MRKUP	AK 8/02/01	GCK
#3	REVSD PER MRKUP	PEI 9/13/01	GCK

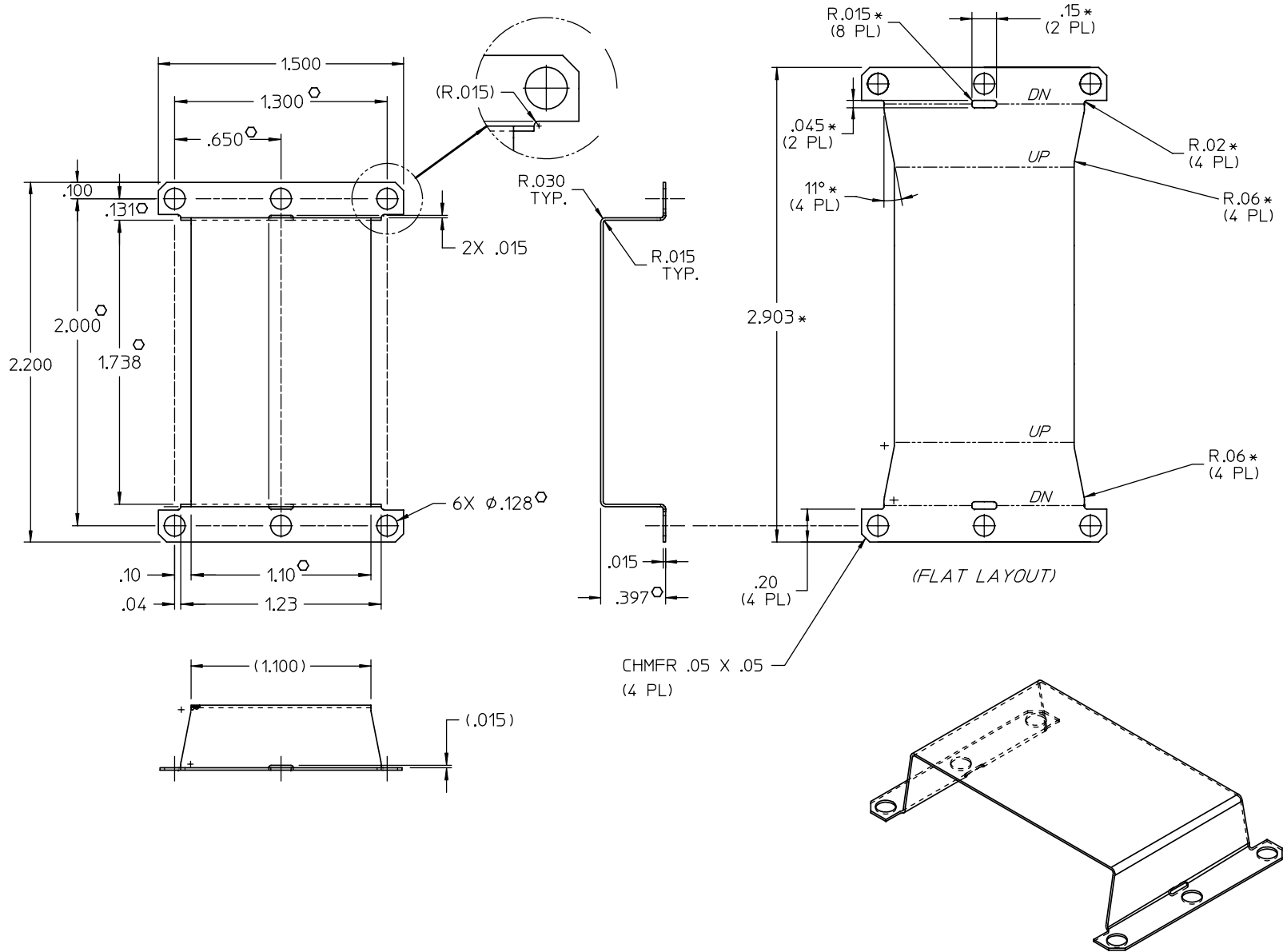

NOTES:

1. MATERIAL: ALUMINUM- (.015) THK, 5052
2. REMOVE BURRS & SHARP EDGES
3. "*" DIMENSIONS ARE NOT FOR VICOR INSPECTION.
4. "O" DENOTES CRITICAL CHARACTERISTICS FOR LOT INSPECTION.
5. FINISH: CLEAR CHROMATE

DRAWN BY A. KUMAR		DATE 5/08/01			
UNLESS OTHERWISE SPECIFIED DIMENSIONS ARE IN INCHES - TOLERANCES ARE: FRACTIONS: DECIMALS ANGLES +1/64 .XX= .01 *° .XXX= .005 *°					
THIRD ANGLE PROJECTION 		SIZE C	FSCM NO. 67131	DWG NO. 21241	REV # 3
DO NOT SCALE DRAWING		SCALE 2X	SHEET 1 OF 1		