

FUJI POWER MOSFET Super FAP-G Series

N-CHANNEL SILICON POWER MOSFET

Features

- High speed switching
- Low on-resistance
- No secondary breakdown
- Low driving power
- Avalanche-proof

Applications

- Switching regulators
- DC-DC converters
- UPS (Uninterruptible Power Supply)

Maximum ratings and characteristic Absolute maximum ratings

($T_c=25^\circ\text{C}$ unless otherwise specified)

Item	Symbol	Ratings	Unit	Remarks
Drain-source voltage	V_{DS}	500	V	
	V_{DSX}	500	V	$V_{GS}=-30\text{V}$
Continuous drain current	I_D	± 19	A	
Pulsed drain current	$I_{D(puls)}$	± 76	A	
Gate-source voltage	V_{GS}	± 30	V	
Non-Repetitive Maximum avalanche current	I_{AS}	19	A	$T_{ch} \leq 150^\circ\text{C}$
Non-Repetitive Maximum avalanche energy	E_{AS}	245.3	mJ	$L=1.25\text{mH}$ $V_{CC}=50\text{V}^*2$
Maximum Drain-Source dV/dt	dV_{DS}/dt	20	kV/s	$V_{DS} \leq 500\text{V}$
Peak diode recovery dV/dt	dV/dt	5	kV/ μs	*3
Max. power dissipation	P_D	2.50	W	$T_a=25^\circ\text{C}$
		235		$T_c=25^\circ\text{C}$
Operating and storage temperature range	T_{ch}	+150	$^\circ\text{C}$	
	T_{stg}	-55 to +150	$^\circ\text{C}$	

*2 See to Avalanche Energy Graph

*3 $I_F \leq -I_D$, $-di/dt=50\text{A}/\mu\text{s}$, $V_{CC} \leq BV_{DS}$, $T_{ch} \leq 150^\circ\text{C}$

Electrical characteristics ($T_c=25^\circ\text{C}$ unless otherwise specified)

Item	Symbol	Test Conditions	Min.	Typ.	Max.	Units
Drain-source breakdown voltage	$V_{(BR)DSS}$	$I_D=250\mu\text{A}$ $V_{GS}=0\text{V}$	500			V
Gate threshold voltage	$V_{GS(th)}$	$I_D=250\mu\text{A}$ $V_{DS}=V_{GS}$	3.0		5.0	V
Zero gate voltage drain current	I_{DSS}	$V_{DS}=500\text{V}$ $V_{GS}=0\text{V}$ $T_{ch}=25^\circ\text{C}$			25	μA
		$V_{DS}=400\text{V}$ $V_{GS}=0\text{V}$ $T_{ch}=125^\circ\text{C}$			250	
Gate-source leakage current	I_{GSS}	$V_{GS}=\pm 30\text{V}$ $V_{DS}=0\text{V}$		10	100	nA
Drain-source on-state resistance	$R_{DS(on)}$	$I_D=9.5\text{A}$ $V_{GS}=10\text{V}$		0.29	0.38	Ω
Forward transconductance	g_{fs}	$I_D=9.5\text{A}$ $V_{DS}=25\text{V}$	7.5	15		S
Input capacitance	C_{iss}	$V_{DS}=25\text{V}$		1560	2340	pF
Output capacitance	C_{oss}	$V_{GS}=0\text{V}$		230	345	
Reverse transfer capacitance	C_{rss}	$f=1\text{MHz}$		8	12	
Turn-on time t_{on}	$t_{d(on)}$	$V_{CC}=300\text{V}$ $I_D=9.5\text{A}$		29	43.5	ns
	t_r	$V_{GS}=10\text{V}$		13	19.5	
Turn-off time t_{off}	$t_{d(off)}$	$R_{GS}=10\Omega$		56	84	
	t_f			8	12	
Total Gate Charge	Q_G	$V_{CC}=250\text{V}$		34	51	nC
Gate-Source Charge	Q_{GS}	$I_D=19\text{A}$		13	19.5	
Gate-Drain Charge	Q_{GD}	$V_{GS}=10\text{V}$		10	15	
Avalanche capability	I_{AV}	$L=1.25\text{mH}$ $T_{ch}=25^\circ\text{C}$	19			A
Diode forward on-voltage	V_{SD}	$I_F=19\text{A}$ $V_{GS}=0\text{V}$ $T_{ch}=25^\circ\text{C}$		1.20	1.50	V
Reverse recovery time	t_{rr}	$I_F=19\text{A}$ $V_{GS}=0\text{V}$		0.57		μs
Reverse recovery charge	Q_{rr}	$-di/dt=100\text{A}/\mu\text{s}$ $T_{ch}=25^\circ\text{C}$		7.0		μC

Thermal characteristics

Item	Symbol	Test Conditions	Min.	Typ.	Max.	Units
Thermal resistance	$R_{th(ch-c)}$	channel to case			0.532	$^\circ\text{C}/\text{W}$
	$R_{th(ch-a)}$	channel to ambient			50.0	$^\circ\text{C}/\text{W}$

Outline Drawings [mm]

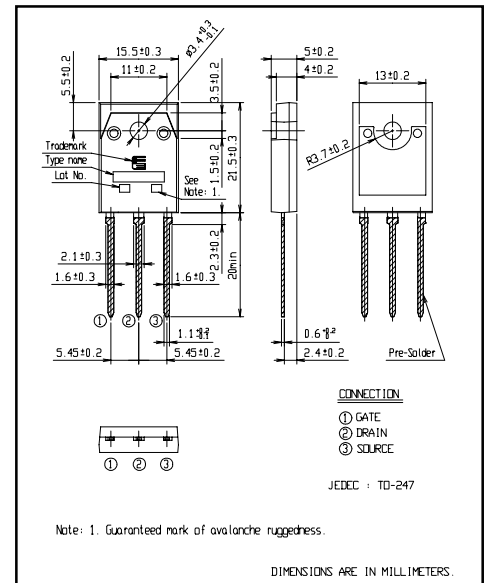

Equivalent circuit schematic

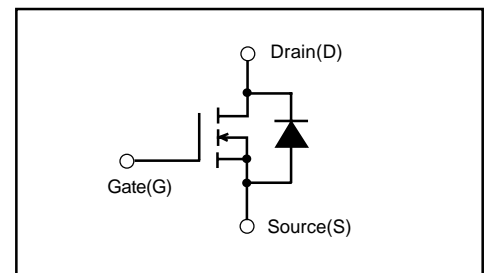

Characteristics

