

GENERAL DESCRIPTION

The 3001 is a common base transistor capable of providing 1 watt of CW RF output power at 3000 MHz. This hermetically sealed transistor is specifically designed for telemetry and telecommunications applications. It uses gold metalization and diffused ballasting to provide high reliability and supreme ruggedness.

3001
1 WATT - 28 VOLTS
3000 MHz

MICROWAVE CW BIPOLAR

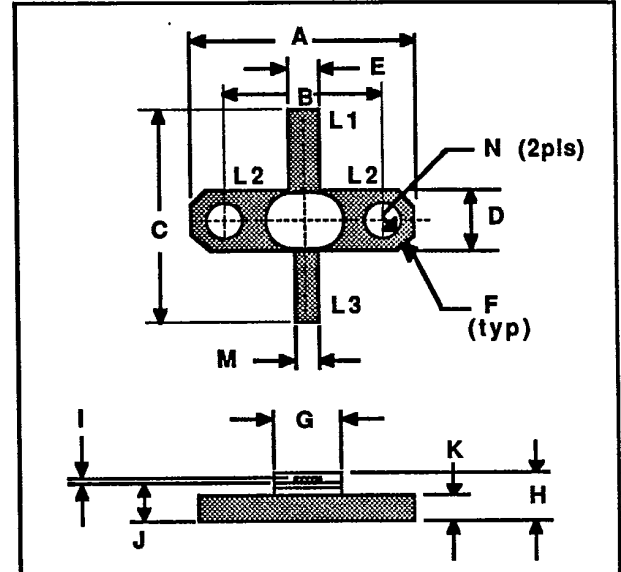

ABSOLUTE MAXIMUM RATINGS

Maximum Power Dissipation @ 25°C Case Temperature	5W
Maximum Voltage and Current	
BVces Collector to Emitter Voltage	50 V
BVebo Emitter to Base Voltage	3.5 V
Ic Collector Current	0.12A
Maximum Temperatures	
Storage Temperature	-65 to +200 °C
Operating Junction Temperature	+200 °C

L1 : B	DIM	Millimeter	TOL	Inches	TOL
L2 : E	A	20.32	.13	.800	.005
L3 : C	B	14.27	.13	.562	.005
	C	18.03	MIN	.710	MIN
	D	5.84	.13	.230	.005
	E	3.05	.13	.120	.005
	F	45°	5°	45°	5°
	G	5.84	.13	.230	.005
	H	4.57	REF	.180	REF
	I	0.13	.02	.005	.001
	J	3.81	.13	.150	.005
	K	1.52	.13	.060	.005
	M	1.27	.13	.050	.005
	N	3.30	.13	.130	.005

POWER OUTPUT VS POWER INPUT VS FREQUENCY (TYPICAL)

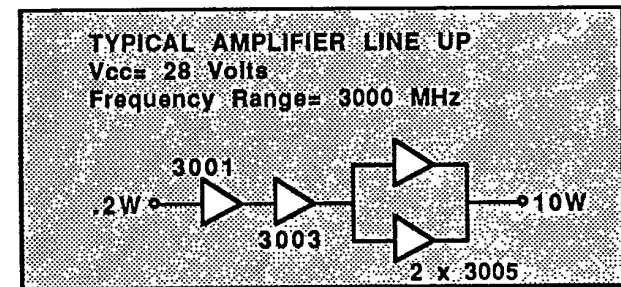
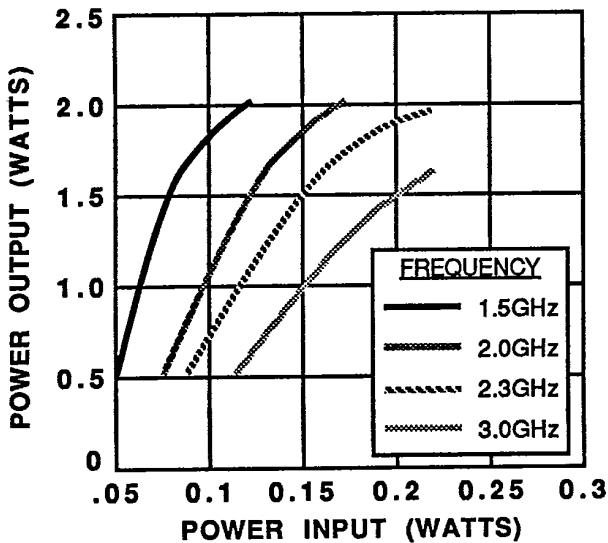

3001-2

ELECTRICAL CHARACTERISTICS¹

SYMBOL	CHARACTERISTICS	TEST CONDITIONS	MIN.	TYP.	MAX.	UNITS
P _{out}	Power Output	f = 3.0 GHz V _{cc} = 28V	1.0			Watts
P _{in}	Power Input				0.2	Watts
P _g	Power Gain		7.0	8.5		dB
η _c	Collector Efficiency		30			%
VSWR	Load Mismatch Tolerance				∞:1	
BV _{ebo}	Breakdown Voltage (Emitter to Base)	I _c = 0A, I _e = 1.0mA	3.5			Volts
BV _{ces}	Breakdown Voltage (Collector to Emitter)	V _{be} = 0A, I _c = 10mA	50			Volts
BV _{cbo}	Breakdown Voltage (Collector - Base)	I _e = 0A, I _c = 1mA	45			Volts
I _{cbo}	Collector Leakage Current	I _e = 0A, V _{cb} = 28V			0.5	mA
h _{FE}	DC-Current Gain	V _{ce} = 5V, I _c = 100mA	10			
θ _{jc}	Thermal Resistance	T _c = 25°C			35	°C/W

Note 1: T_c = +25°C unless otherwise specified

POWER OUTPUT VS FREQUENCY (TYPICAL)

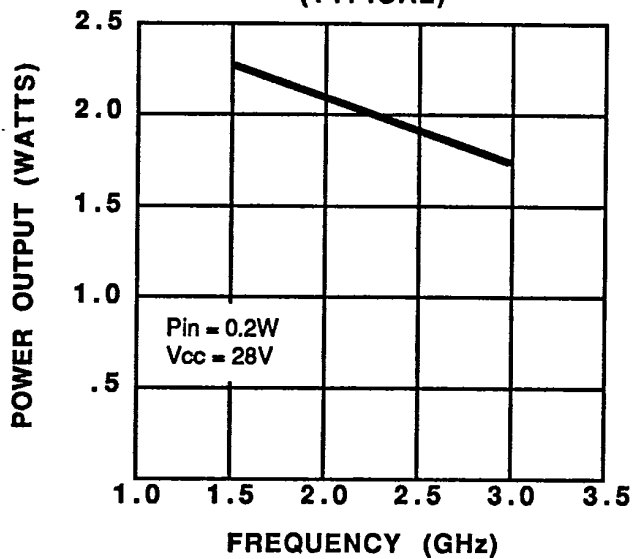

EFFICIENCY VS FREQUENCY (TYPICAL)

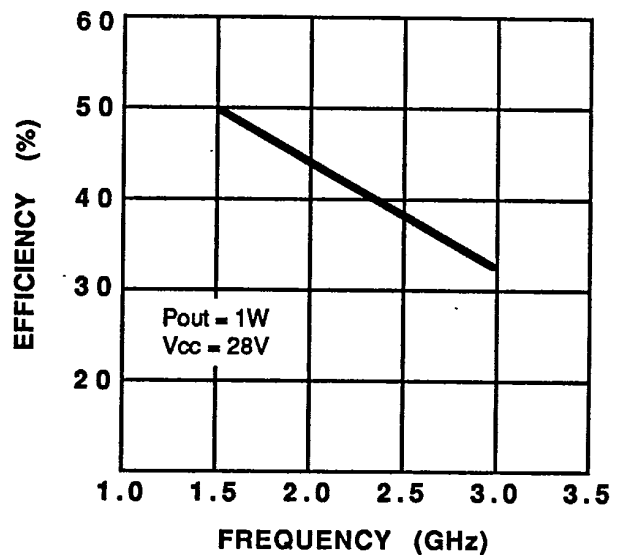

SPECIFICATIONS MAY BE SUBJECT TO CHANGE WITHOUT NOTICE

454

**SMITH CHART
3001**

NORMALIZED IMPEDANCE AND ADMITTANCE COORDINATES

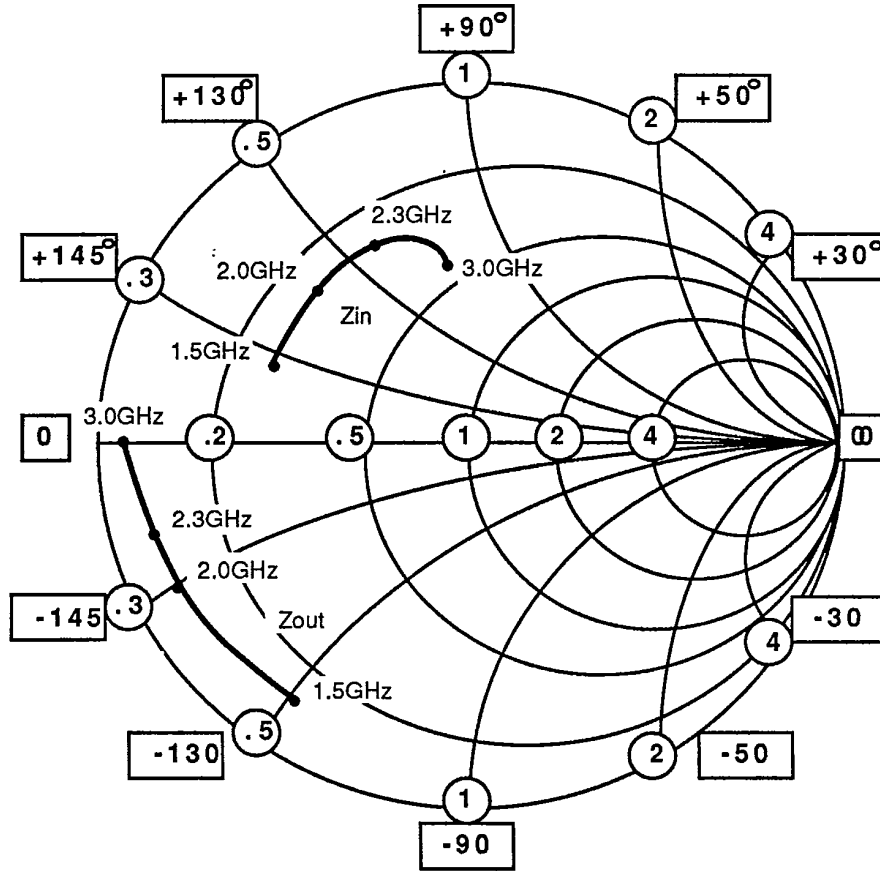

NORMALIZED TO A 50 OHM SYSTEM.

FREQUENCY MHz	Zsource R	JX	FREQUENCY MHz	Zload R	JX
1.5	15	14	1.5	6	25
2.0	16	20	2.0	5	15
2.3	17	27	2.3	4.5	10
3.0	19	32	3.0	4	0

3001-4

3001 TEST AMPLIFIER

f = 3000 MHz

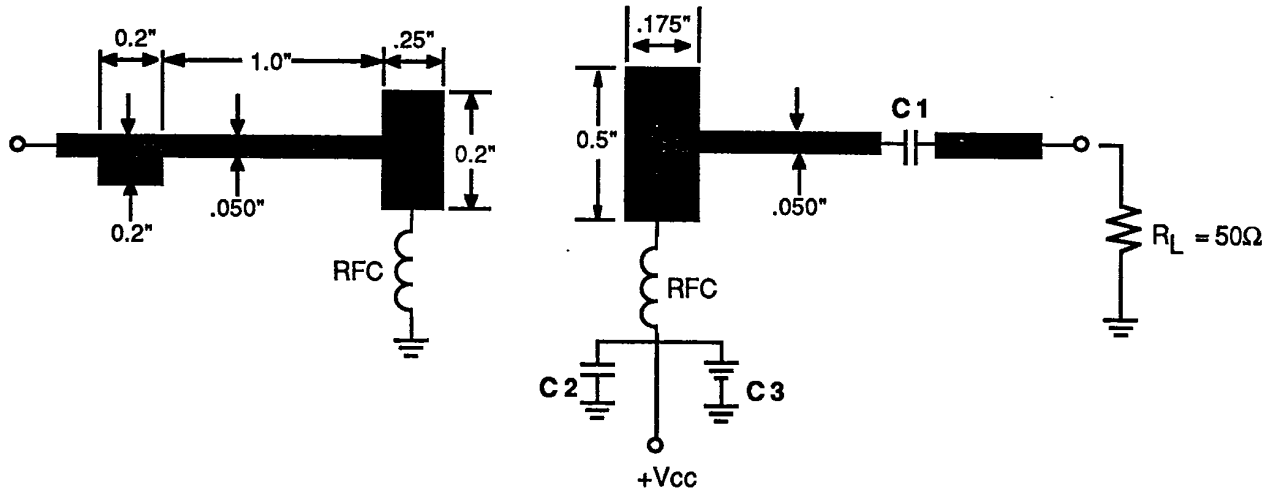

--- MICROSTRIP ON 0.020 TEFLON FIBERGLASS, $\epsilon_r = 2.55$
 C1, C2 --- ATC 'A' 47 pf
 C3 --- 10 μ fd @ 35 Volts

u56