

SCHOTTKY RECTIFIER

3 Amp

Major Ratings and Characteristics

Characteristics	30BQ015	Units
$I_{F(AV)}$ Rectangular waveform	3.0	A
V_{RRM}	15	V
I_{FSM} @ $t_p = 5\mu s$ sine	650	A
V_F @ 3.0Apk, $T_J = 75^\circ C$	0.30	V
T_J	-55 to 100	$^\circ C$

Description / Features

The 30BQ015 surface-mount Schottky rectifier has been designed for applications requiring very low forward drop and small foot prints on PC boards. Typical applications are in disk drives, switching power supplies, converters, free-wheeling diodes, battery charging and reverse battery protection.

- Small footprint, surface mountable
- Very low forward voltage drop
- High frequency operation
- Guard ring for enhanced ruggedness and long-term reliability

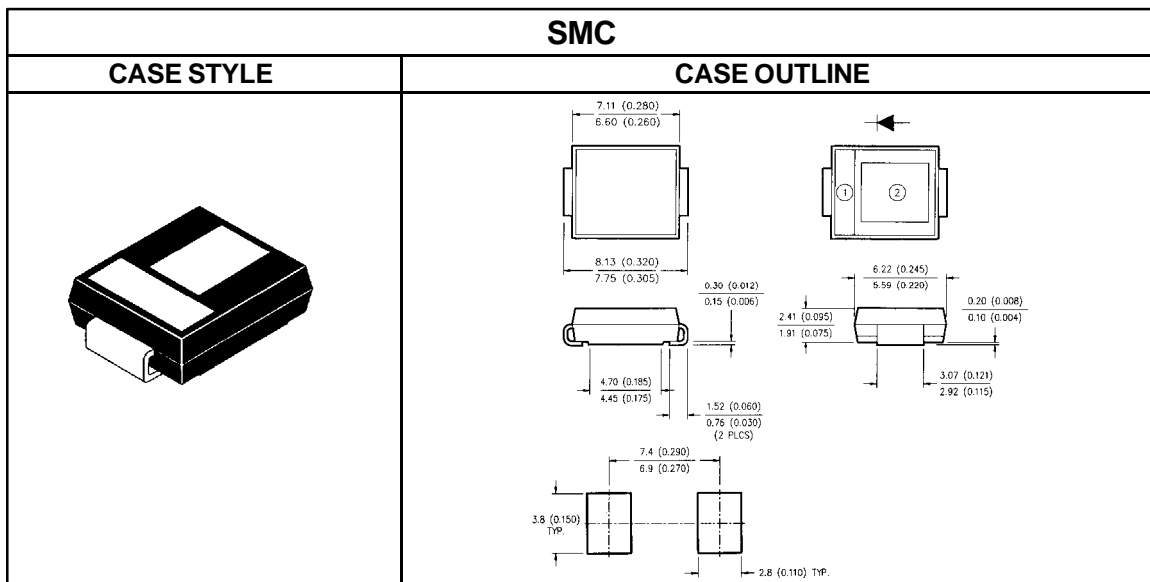

30BQ015



Voltage Ratings

Part number	30BQ015
V _R Max. DC Reverse Voltage (V)	15
V _{RRM} Max. Working Peak Reverse Voltage (V)	25

Absolute Maximum Ratings

Parameters	30BQ	Units	Conditions
I _{F(AV)} Max. Average Forward Current	3.0	A	50% duty cycle @ T _C = 83°C, rectangular waveform
	4.0		50% duty cycle @ T _C = 78°C, rectangular waveform
I _{FSM} Max. Peak One Cycle Non - Repetitive Surge Current	650	A	5μs Sine or 3μs Rect. pulse
	95		10ms Sine or 6ms Rect. pulse
E _{AS} Non - Repetitive Avalanche Energy	9	mJ	T _J = 25°C, I _{AS} = 0.6A, L = 6.6mH
I _{AR} Repetitive Avalanche Current	0.6	A	Current decaying linearly to zero in 1μsec Frequency limited by T _J max. V _A = 1.5 X V _R typical

Electrical Specifications

Parameters	30BQ	Units	Conditions
V _{FM} Max. Forward Voltage Drop ①	0.35	V	@ 3.0A
		V	@ 6.0A
	0.30	V	@ 3.0A
		V	@ 6.0A
I _{RM} Max. Reverse Leakage Current ①	4	mA	T _J = 25°C
	50	mA	T _J = 125°C
C _T Max. Junction Capacitance	1120	pF	V _R = 5V _{DC} , (test signal range 100KHz to 1MHz) 25°C
L _S Typical Series Inductance	3.0	nH	Measured lead to lead 5mm from package body
dv/dt Max. Voltage Rate of Change (Rated V _R)	10,000	V/μs	

Thermal-Mechanical Specifications

Parameters	30BQ	Units	Conditions
T _J Max. Junction Temperature Range	-55 to 100	°C	
T _{STG} Max. Storage Temperature Range	-55 to 100	°C	
R _{thJA} Max. Thermal Resistance, Junction to Ambient	12	°C/W	DC operation
R _{thJL} Max. Thermal Resistance, Junction to Lead ②	46	°C/W	DC operation
wt Approximate Weight	0.24	g	
Case Style	SMC		Similar to DO-214AB

① Pulse Width < 300μs, Duty Cycle < 2%

② Mounted 1 inch square PCB, thermal probe connected to lead 2mm from package

Refer to the Appendix Section for the following:

Appendix D: Tape and Reel Information — See page 339.