

# SBD Type : 31DQ03L

## OUTLINE DRAWING

### FEATURES

- \* Extremely Low Forward Voltage Drop
- \* Low Power Loss, High Efficiency
- \* High Surge Capability
- \* 30volts trough 100volts Types Available

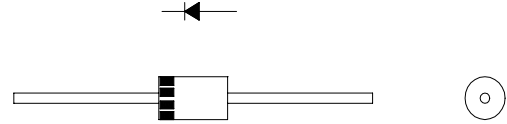

### Maximum Ratings

Approx Net Weight:1.18g

Rating	Symbol	31DQ03L			Unit
Repetitive Peak Reverse Voltage	$V_{RRM}$	30			V
Average Rectified Output Current	$I_O$	1.9	$T_a=25^{\circ}C$	Half Sine Wave Resistive Load	A
		3.0	$T_a=53^{\circ}C$		
RMS Forward Current	$I_{F(RMS)}$	4.71			A
Surge Forward Current	$I_{FSM}$	120	Half Sine Wave,1cycle,Non-repetitive		A
Operating JunctionTemperature Range	$T_{jw}$	- 40 to + 150			$^{\circ}C$
Storage Temperature Range	$T_{stg}$	- 40 to + 150			$^{\circ}C$

### Electrical • Thermal Characteristics

Characteristics	Symbol	Conditions	Min	Typ	Max	Unit
Peak Reverse Current	$I_{RM}$	$T_j= 25^{\circ}C, V_{RM}= V_{RRM}$	-	-	3	mA
Peak Forward Voltage	$V_{FM}$	$T_j= 25^{\circ}C, I_{FM}= 3 A$	-	-	0.45	V
Thermal Resistance(Junction to Ambient)	$R_{th(j-a)}$	Without Fin or P.C.Board	-	-	80	$^{\circ}C/W$
		With Fin *1			34	

\*1 :20x20x1t(mm) Copper plates, L=5mm, Both Sides

31DQ\_ OUTLINE DRAWING (Dimensions in mm)

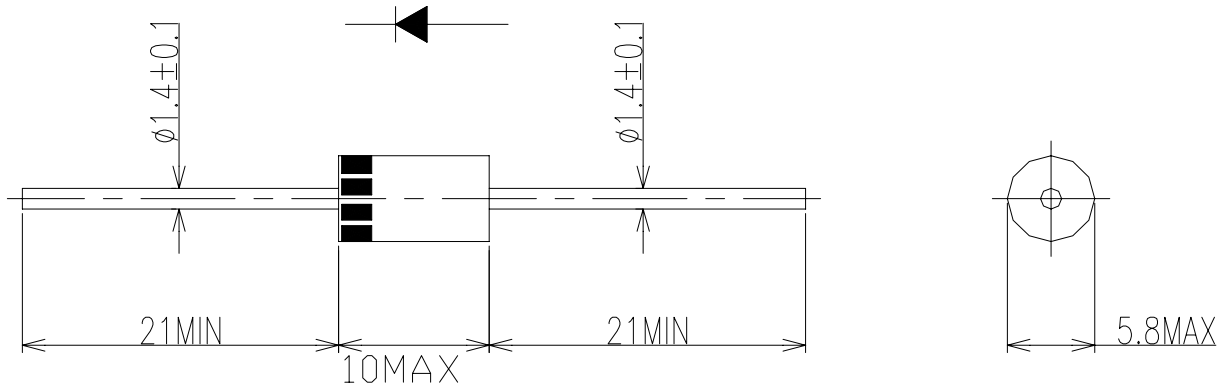

FORWARD CURRENT VS. VOLTAGE

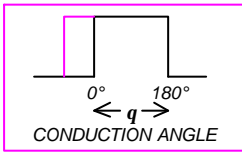
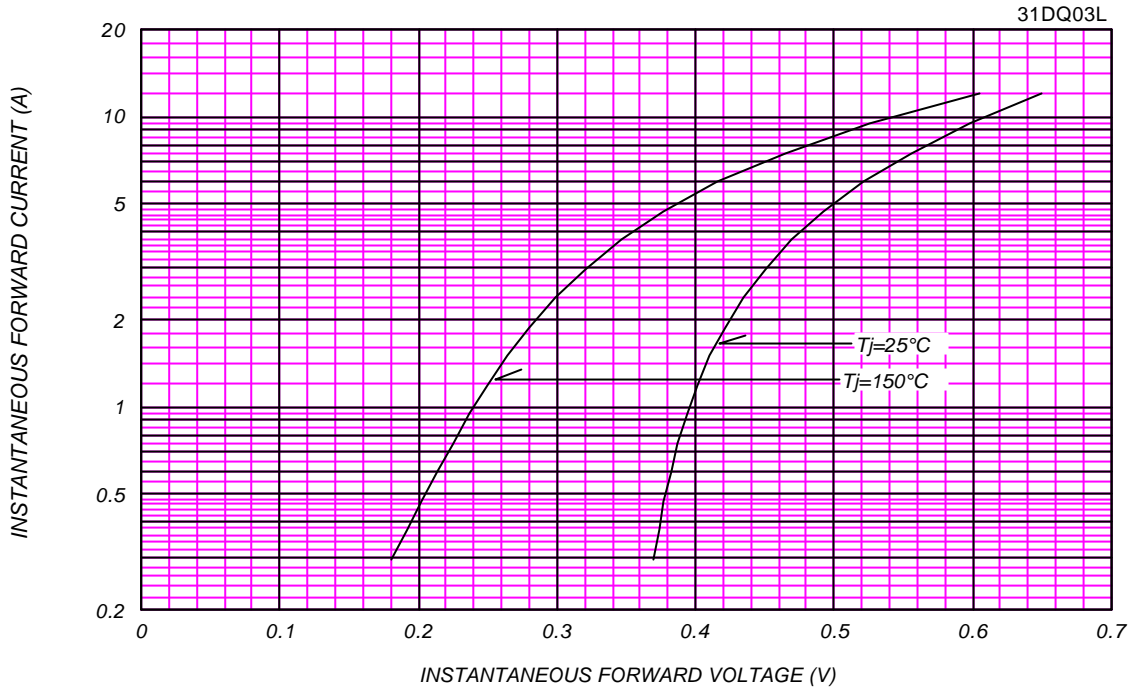

AVERAGE FORWARD POWER DISSIPATION

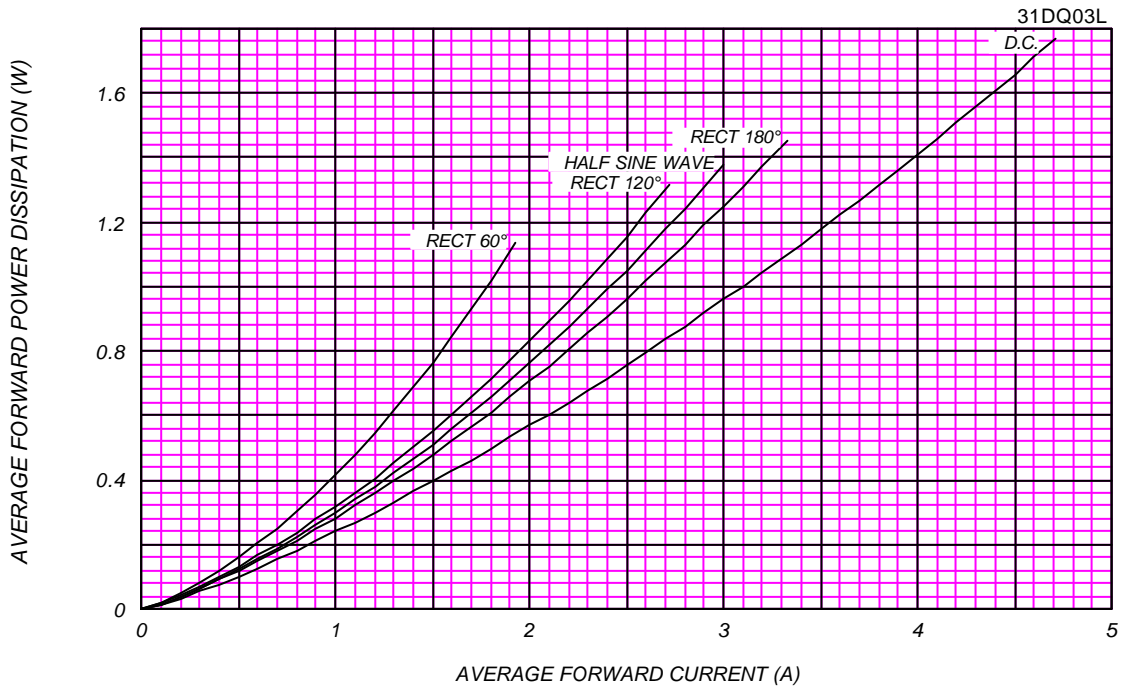

PEAK REVERSE CURRENT VS. PEAK REVERSE VOLTAGE

T<sub>j</sub> = 150 °C

31DQ03L

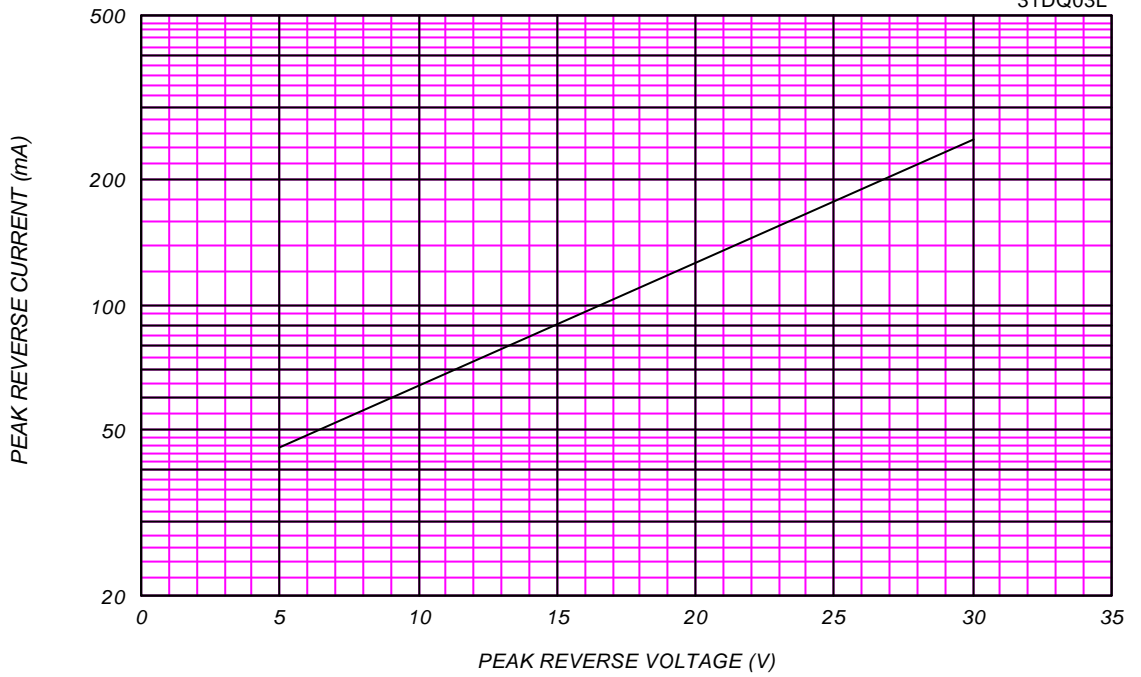

AVERAGE REVERSE POWER DISSIPATION

31DQ03L

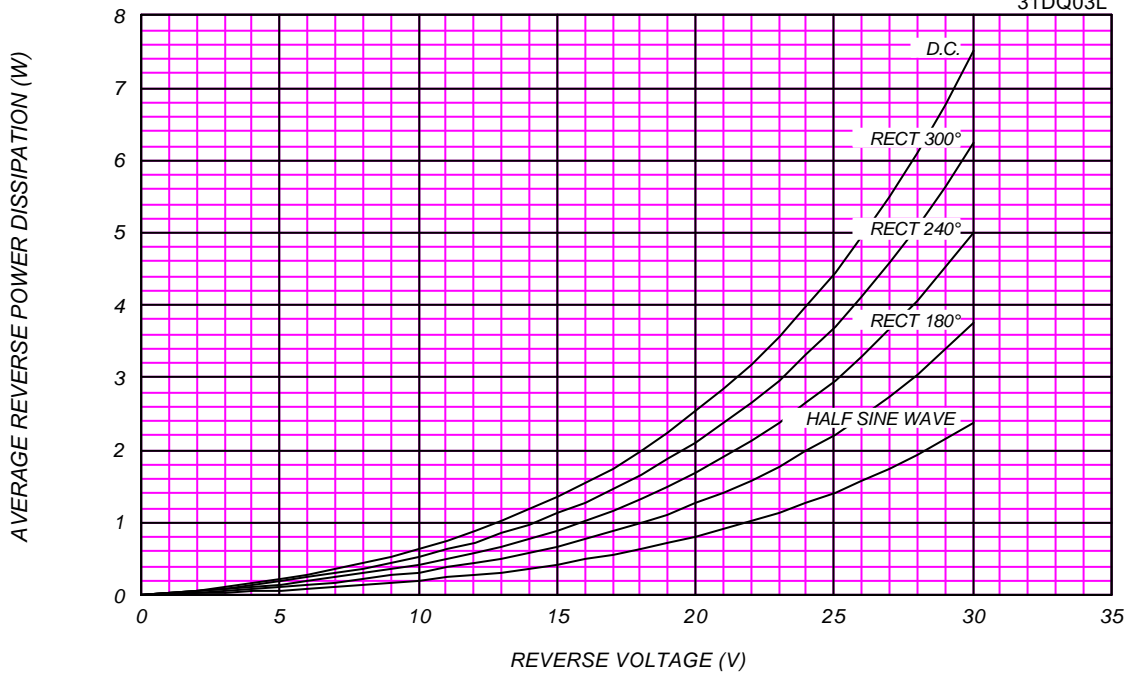

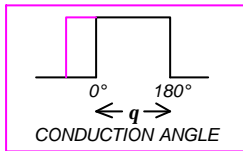

### AVERAGE FORWARD CURRENT VS. AMBIENT TEMPERATURE

Without Fin or P.C. Board,  $V_{RM}=30V$

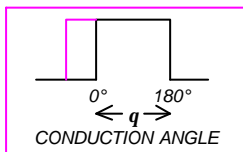
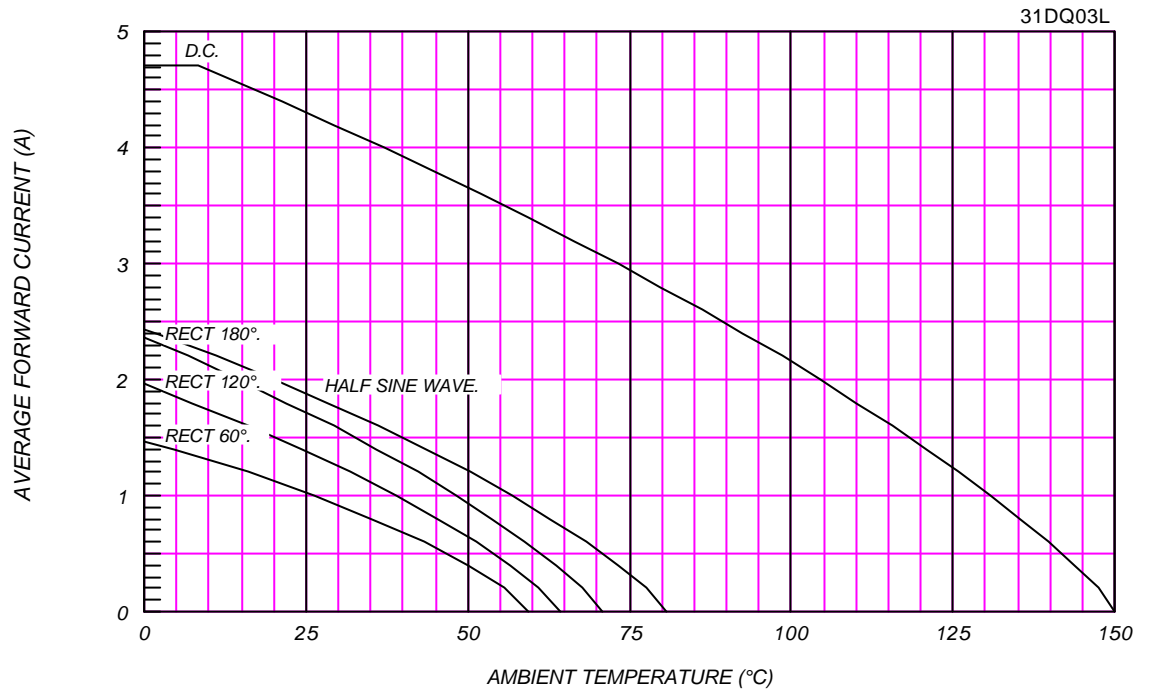

### AVERAGE FORWARD CURRENT VS. AMBIENT TEMPERATURE

With Cu Fin $\times$ 2 (20 $\times$ 20 $\times$ 1t, L=5mm, Both Sides),  $V_{RM}=30V$

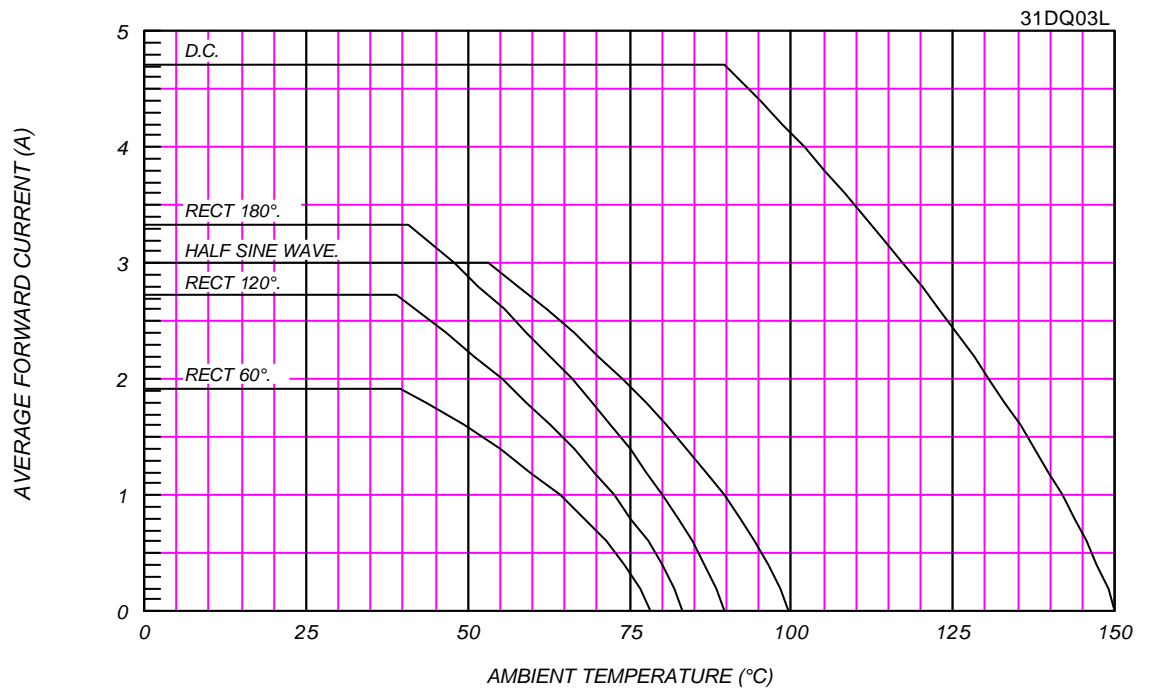

### SURGE CURRENT RATINGS

f=50Hz, Half Sine Wave, Non-Repetitive, No Load

31DQ03L

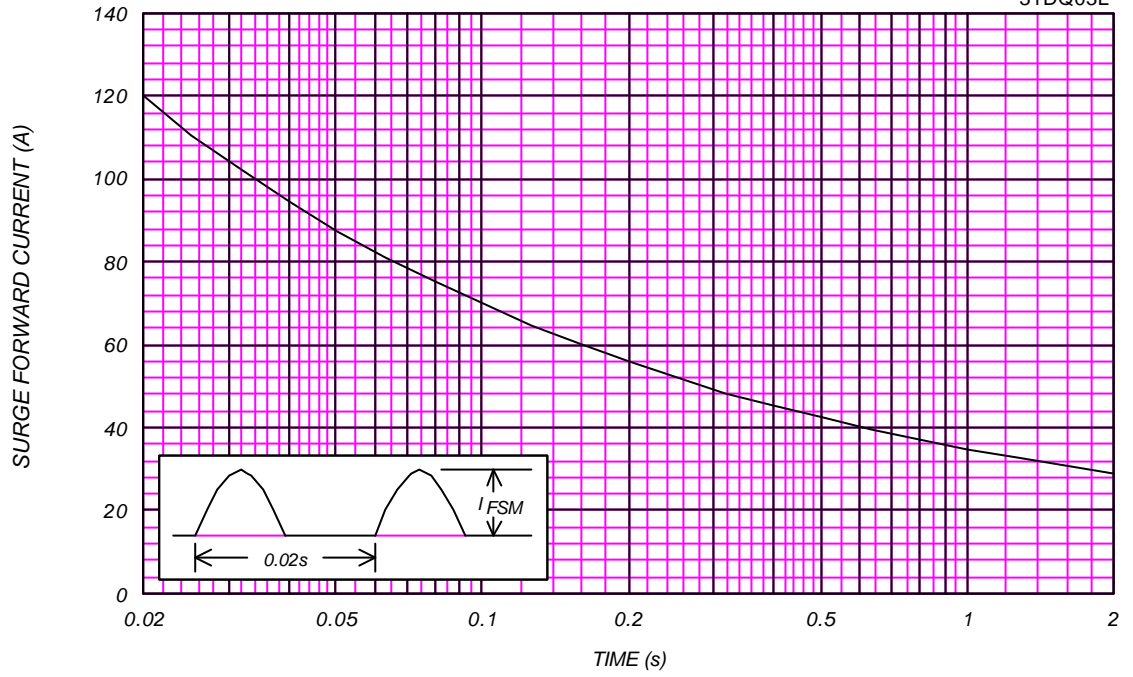

### JUNCTION CAPACITANCE VS. REVERSE VOLTAGE

$T_j = 25^\circ\text{C}$ ,  $V_m = 20\text{mV}_{\text{RMS}}$ ,  $f = 100\text{kHz}$ , Typical Value

31DQ03L

