

V_{RRM}	=	4500 V
$I_{F(AV)M}$	=	900 A
I_{FSM}	=	16×10^3 A
$V_{(T0)}$	=	1.8 V
r_T	=	0.9 mW
$V_{DC-link}$	=	2400 V

Fast Recovery Diode

5SDF 07H4501

Doc. No. 5SYA1111-02 Oct. 06

- Patented free-floating silicon technology
- Low switching losses
- Optimized for use as large-area snubber diode in GTO converters
- Industry standard housing
- Cosmic radiation withstand rating

Blocking

Maximum rated values ¹⁾

Parameter	Symbol	Conditions	Value	Unit
Repetitive peak reverse voltage	V_{RRM}	$f = 50$ Hz, $t_p = 10$ ms, $T_{vj} = 125^\circ\text{C}$	4500	V
Permanent DC voltage for 100 FIT failure rate	$V_{DC-link}$	Ambient cosmic radiation at sea level in open air. (100% Duty)	2400	V
Permanent DC voltage for 100 FIT failure rate	$V_{DC-link}$	Ambient cosmic radiation at sea level in open air. (5% Duty)	2800	V

Characteristic values

Parameter	Symbol	Conditions	min	typ	max	Unit
Repetitive peak reverse current	I_{RRM}	$V_R = V_{RRM}$, $T_{vj} = 125^\circ\text{C}$			200	mA

Mechanical data

Maximum rated values ¹⁾

Parameter	Symbol	Conditions	min	typ	max	Unit
Mounting force	F_m		36	40	44	kN
Acceleration	a	Device unclamped			50	m/s^2
Acceleration	a	Device clamped			200	m/s^2

Characteristic values

Parameter	Symbol	Conditions	min	typ	max	Unit
Weight	m				0.83	kg
Housing thickness	H		26.0		26.4	mm
Surface creepage distance	D_s		30			mm
Air strike distance	D_a		20			mm

Note 1 Maximum rated values indicate limits beyond which damage to the device may occur

ABB Switzerland Ltd, Semiconductors reserves the right to change specifications without notice.



On-state

Maximum rated values ¹⁾

Parameter	Symbol	Conditions	min	typ	max	Unit
Max. average on-state current	$I_{F(AV)M}$	Half sine wave, $T_C = 85\text{ °C}$			900	A
Max. RMS on-state current	$I_{F(RMS)}$				1400	A
Max. peak non-repetitive surge current	I_{FSM}	$t_p = 10\text{ ms}$, $T_{vj} = 125\text{ °C}$, $V_R = 0\text{ V}$			16×10^3	A
Limiting load integral	I^2t				1.28×10^6	A ² s
Max. peak non-repetitive surge current	I_{FSM}	$t_p = 1\text{ ms}$, $T_{vj} = 125\text{ °C}$, $V_R = 0\text{ V}$			40×10^3	A
Limiting load integral	I^2t				800×10^3	A ² s

Characteristic values

Parameter	Symbol	Conditions	min	typ	max	Unit
On-state voltage	V_F	$I_F = 3000\text{ A}$, $T_{vj} = 125\text{ °C}$			4.5	V
Threshold voltage	$V_{(T0)}$	$T_{vj} = 125\text{ °C}$ $I_F = 500 \dots 5000\text{ A}$			1.8	V
Slope resistance	r_T				0.9	mΩ

Turn-on

Characteristic values

Parameter	Symbol	Conditions	min	typ	max	Unit
Peak forward recovery voltage	V_{FRM}	$di_F/dt = 500\text{ A}/\mu\text{s}$, $T_{vj} = 125\text{ °C}$			55	V

Turn-off

Characteristic values

Parameter	Symbol	Conditions	min	typ	max	Unit
Reverse recovery current	I_{RM}	$di_F/dt = 100\text{ A}/\mu\text{s}$, $T_j = 125\text{ °C}$, $I_{FQ} = 1000\text{ A}$,			260	A
Reverse recovery charge	Q_{rr}				1700	μC
Turn-off energy	E_{rr}	$R_S = 22\text{ Ω}$, $C_S = 0.22\text{ μF}$			TBD	J

Thermal

Maximum rated values ^{Note 1}

Parameter	Symbol	Conditions	min	typ	max	Unit
Operating junction temperature range	T_{vj}		-40		125	°C
Storage temperature range	T_{stg}		-40		125	°C

Characteristic values

Parameter	Symbol	Conditions	min	typ	max	Unit
Thermal resistance junction to case	$R_{th(j-c)}$	Double-side cooled $F_m = 36...44$ kN			12	K/kW
	$R_{th(j-c)A}$	Anode-side cooled $F_m = 36...44$ kN			24	K/kW
	$R_{th(j-c)C}$	Cathode-side cooled $F_m = 36...44$ kN			24	K/kW
Thermal resistance case to heatsink	$R_{th(c-h)}$	Double-side cooled $F_m = 36...44$ kN			3	K/kW
	$R_{th(c-h)}$	Single-side cooled $F_m = 36...44$ kN			6	K/kW

Analytical function for transient thermal impedance:

$$Z_{th(j-c)}(t) = \sum_{i=1}^n R_{th i} (1 - e^{-t/t_i})$$

i	1	2	3	4
$R_{th i}$ (K/kW)	7.440	2.000	1.840	0.710
τ_i (s)	0.4700	0.0910	0.0110	0.0047

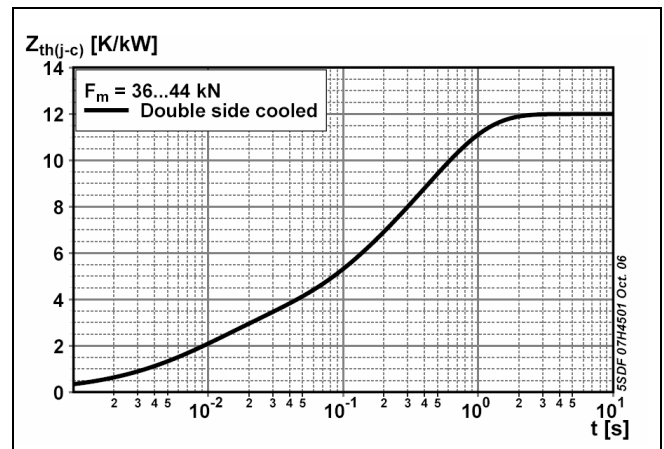

Fig. 1 Transient thermal impedance junction-to-case

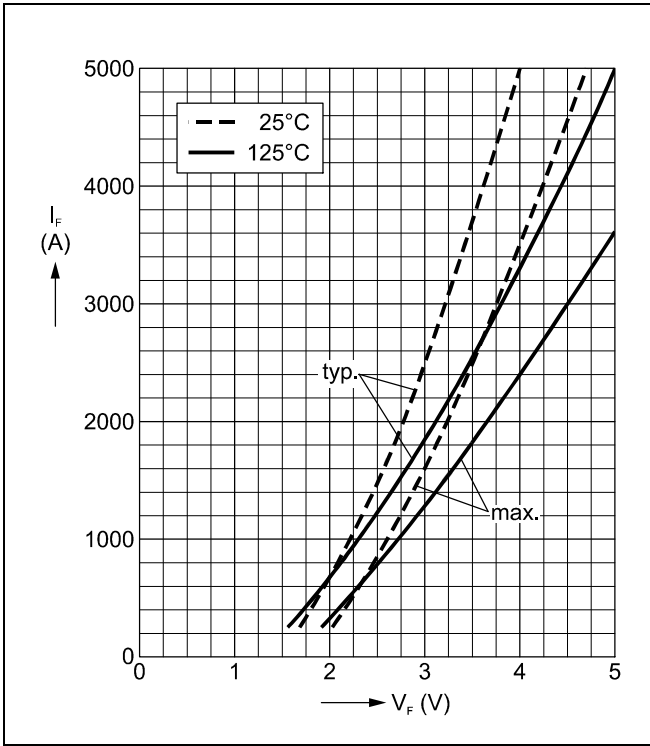

Fig. 2 Max. on-state voltage characteristics

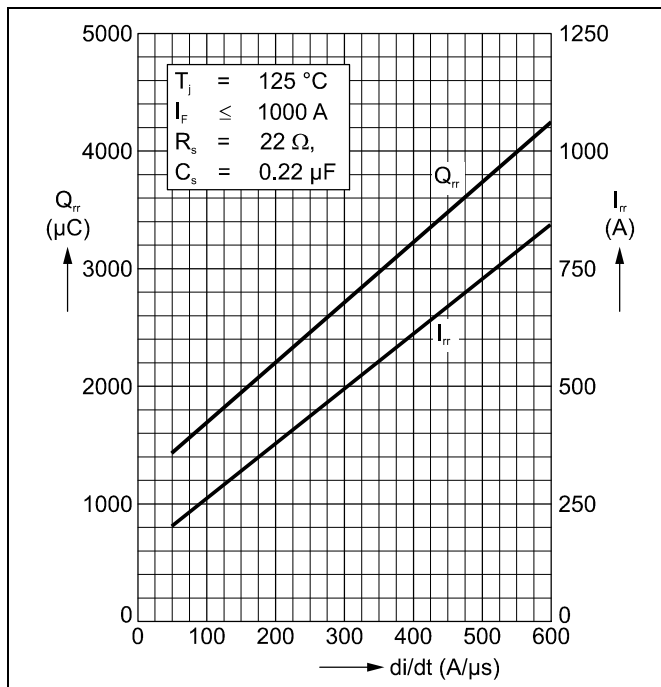

Fig. 3 Upper scatter range of repetitive reverse recovery charge vs reverse current rise rate.

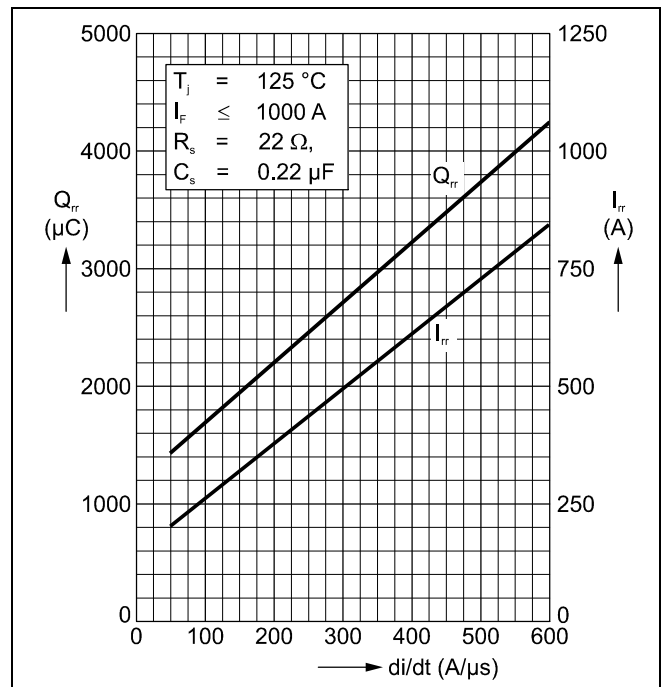

Fig. 4 Upper scatter range of reverse recovery current vs reverse current rise rate

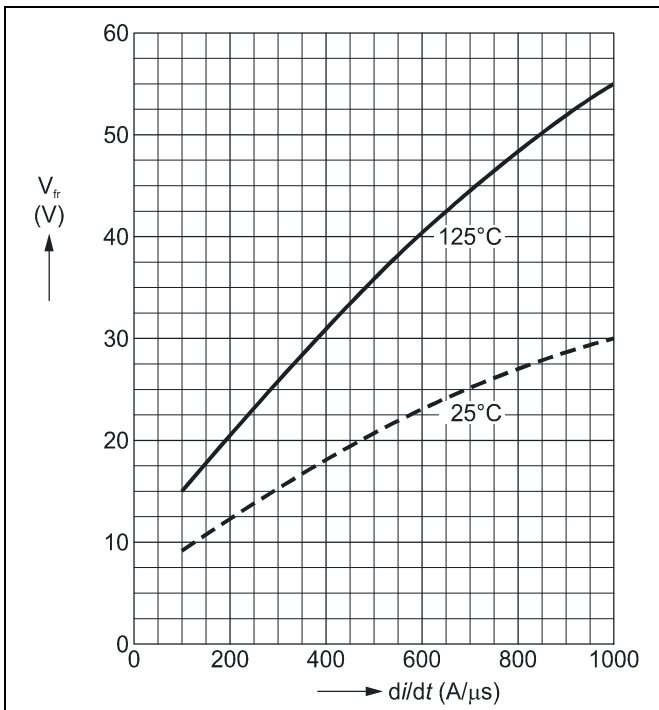

Fig. 5 Forward recovery vs. turn on di/dt (max. values)

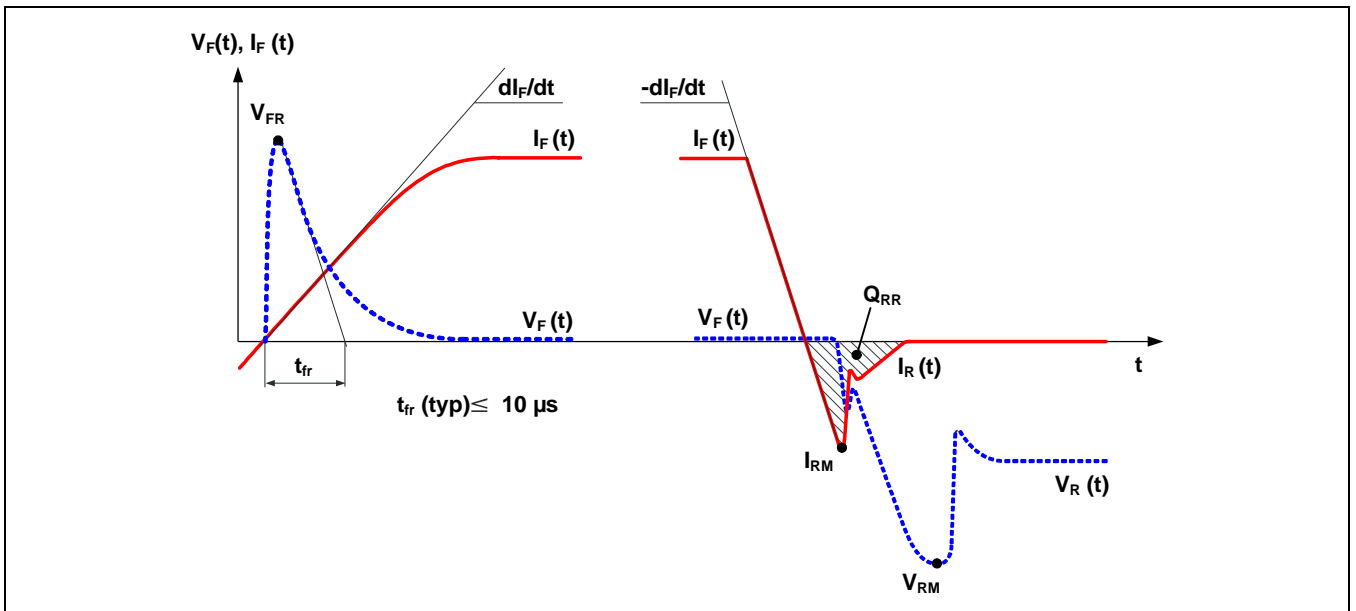

Fig. 6 General current and voltage waveforms

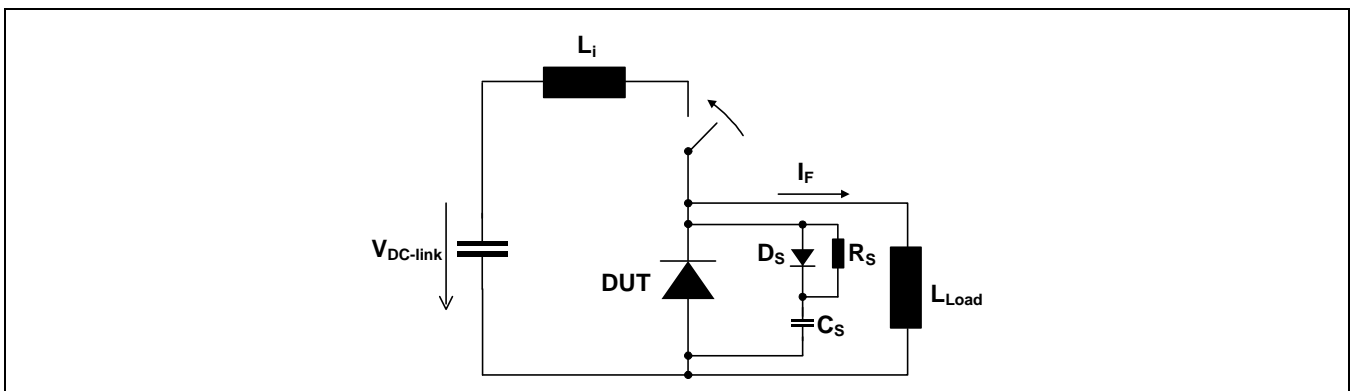

Fig. 7 Test circuit.

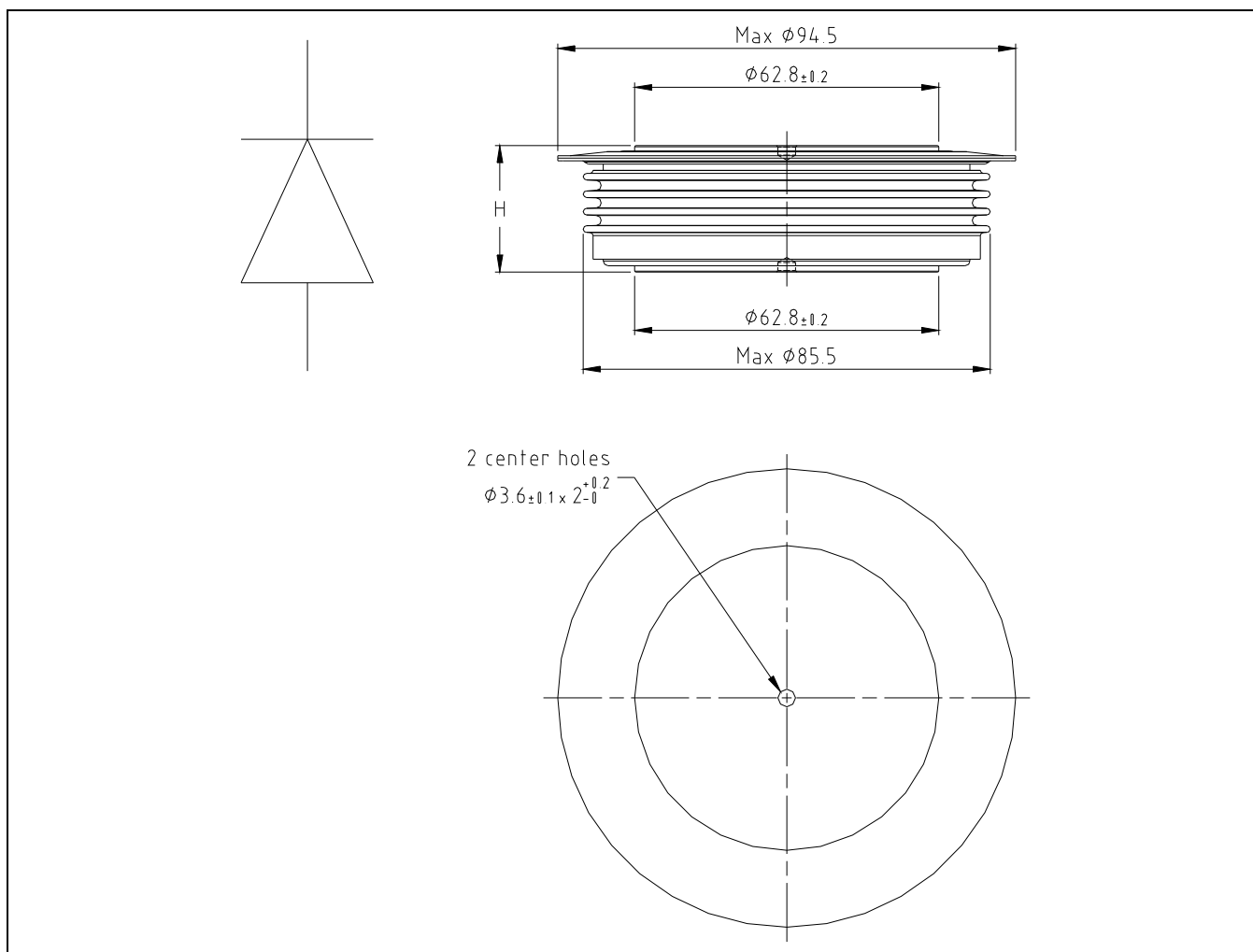

Fig. 8 Outline drawing, all dimensions are in millimeters and represent nominal values unless stated otherwise

Related documents:

Doc. Nr	Titel
5SYA 2036	Recommendations regarding mechanical clamping of Press Pack High Power Semiconductors
5SZK 9104	Specification of environmental class for pressure contact diodes, PCTs and GTO, STORAGE available on request, please contact factory
5SZK 9105	Specification of environmental class for pressure contact diodes, PCTs and GTO, TRANSPORTATION available on request, please contact factory

Please refer to <http://www.abb.com/semiconductors> for current version of documents.

ABB Switzerland Ltd, Semiconductors reserves the right to change specifications without notice.



ABB Switzerland Ltd
Semiconductors
 Fabrikstrasse 3
 CH-5600 Lenzburg, Switzerland

Doc. No. 5SYA1111-02 Oct. 06

Telephone +41 (0)58 586 1419
 Fax +41 (0)58 586 1306
 Email abbsem@ch.abb.com
 Internet www.abb.com/semiconductors