



**ATTENTION**  
OBSERVE PRECAUTIONS  
FOR HANDLING  
ELECTROSTATIC  
DISCHARGE  
SENSITIVE  
DEVICES

AAA5060SUREVGEC

HYPER RED / GREEN

### Features

- CHIPS CAN BE CONTROLLED SEPARATELY.
- SUITABLE FOR ALL SMT ASSEMBLY AND SOLDER PROCESS.
- AVAILABLE ON TAPE AND REEL.
- PACKAGE: 500PCS / REEL.
- RoHS COMPLIANT.

### Description

The Hyper Red source color devices are made with DH InGaAlP on GaAs substrate Light Emitting Diode. The Green source color devices are made with InGaN on SiC Light Emitting Diode. Static electricity and surge damage the LEDs. It is recommended to use a wrist band or anti-electrostatic glove when handling the LEDs. All devices, equipment and machinery must be electrically grounded.

### Package Dimensions

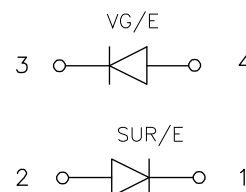
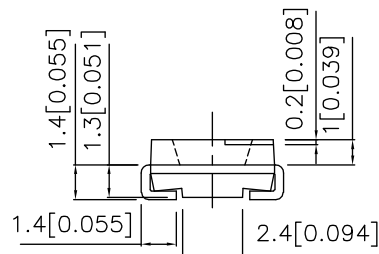
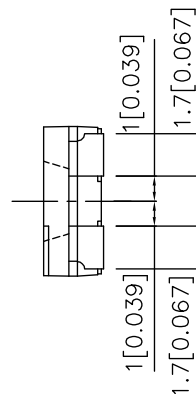
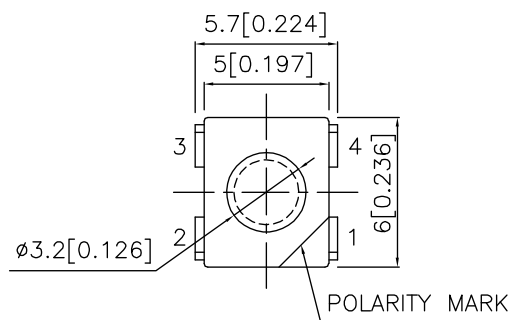

**Notes:**

1. All dimensions are in millimeters (inches).
2. Tolerance is  $\pm 0.25(0.01)$  unless otherwise noted.
3. Specifications are subject to change without notice.

## Selection Guide

Part No.	Dice	Lens Type	Iv (mcd) @ 50mA*30 mA		Viewing Angle
			Min.	Typ.	2 θ 1/2
AAA5060SUREVGEC	HYPER RED (InGaAlP)	WATER CLEAR	380	700	100°
	GREEN (InGaN)		*280	*600	

Notes:

1. θ1/2 is the angle from optical centerline where the luminous intensity is 1/2 the optical centerline value.
2. \* Luminous intensity with asterisk is measured at 30mA.

## Electrical / Optical Characteristics at TA=25°C

Symbol	Parameter	Device	Typ.	Max.	Units	Test Conditions
λ <sub>peak</sub>	Peak Wavelength	Hyper Red Green	640 518		nm	I <sub>F</sub> =20mA
λ <sub>D</sub>	Dominant Wavelength	Hyper Red Green	630 525		nm	I <sub>F</sub> =20mA
Δλ <sub>1/2</sub>	Spectral Line Half-width	Hyper Red Green	25 36		nm	I <sub>F</sub> =20mA
C	Capacitance	Hyper Red Green	45 50		pF	V <sub>F</sub> =0V;f=1MHz
V <sub>F</sub>	Forward Voltage	Hyper Red Green	1.9 3.5	2.5 4.5	V	I <sub>F</sub> =20mA
I <sub>R</sub>	Reverse Current	All		10	uA	V <sub>R</sub> = 5V

## Absolute Maximum Ratings at TA=25°C

Parameter	Hyper Red	Green	Units
Power dissipation	125	135	mW
DC Forward Current	50	30	mA
Peak Forward Current [1]	200	150	mA
Reverse Voltage	5	5	V
Operating / Storage Temperature	-40°C To +85°C		

Note:

1. 1/10 Duty Cycle, 0.1ms Pulse Width.

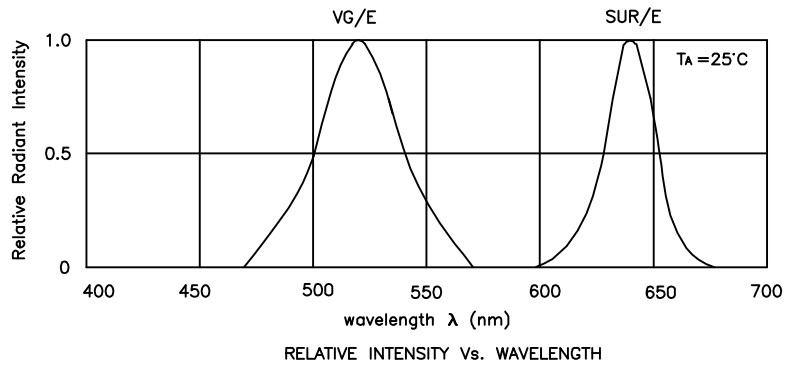

## AAA5060SUREVGEC Hyper Red

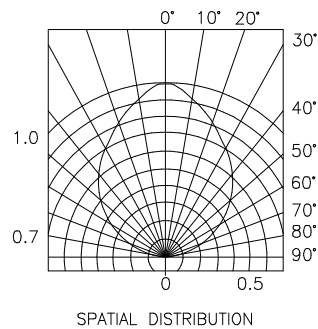
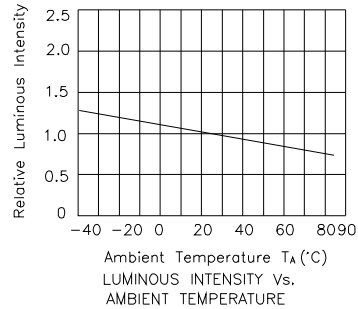
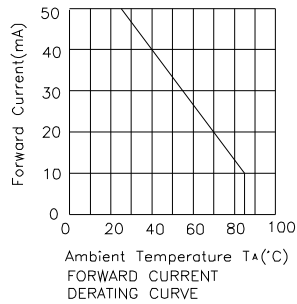
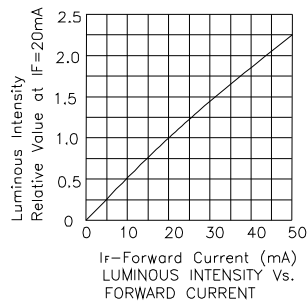
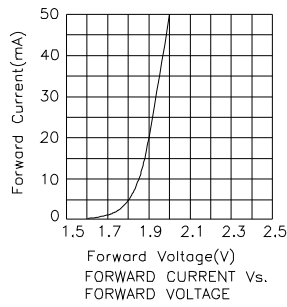

# Kingbright

## Green

