



Details are subject to change without notice

**250-mA MULTI-INPUT LOW-DROPOUT REGULATOR**  
**WITH V<sub>AUX</sub> SWITCH**

**Features**

- Complete Power Management
- Automatic Input Voltage Selection
- Input Voltage Source Detector With Hysteresis
- 250-mA Load Current Capability With VCC50 or VSB50 or AUX33 Input Source
- Integrated Low  $r_{DS(on)}$  Switch
- Regulated Output 3.3V (fixed)
- Output Short Circuit Protection

**Pin Configuration**

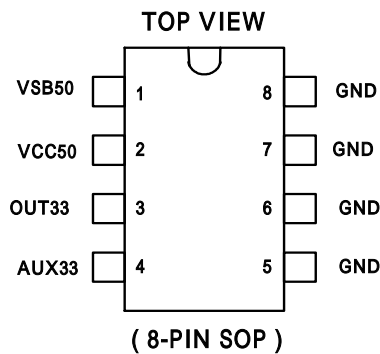

**Description**

The AAT1203 is a multi-input low-dropout regulator designed for LAN cards. It provides constant output supply 3.3V at an output capable of driving a 250-mA load.

The AAT1203 is equipped with regulated power output for systems that have multiple input sources and require constant voltage source with a low-dropout voltage. This is an intelligent power source selection device with a low-dropout regulator for either VCC50 or VSB50 inputs, and a low-resistance bypass switch for the AUX33 input.

The AAT1203 allows transitions to progress smoothly from one input supply to another without generating a glitch outside of the specified range of the 3.3-V output. The device has an incorporated reverse-blocking scheme to prevent excess leakage from the input terminals in the event that the output voltage is greater than the input voltage.

The input voltage is prioritized in the following order: VCC50, VSB50, AUX33.



**Function Table**

INPUT VOLTAGE STATUS (V)			INPUT SELECTED	OUTPUT (V)	OUTPUT (I)(mA)
VCC50	VS50	AUX33	VCC50/VS50/AUX33	OUT33	Iout33
0	0	0	None	0	0
0	0	3.3	AUX33	3.3	250
0	5	0	VS50	3.3	250
0	5	3.3	VS50	3.3	250
5	0	0	VCC50	3.3	250
5	0	3.3	VCC50	3.3	250
5	5	0	VCC50	3.3	250
5	5	3.3	VCC50	3.3	250

**Pin Description**

TERMINAL NAME	TERMINAL NO.	I/O	DESCRIPTION
VS50	1	I	5V Standby Supply Input
VCC50	2	I	5V Main Supply Input
OUT33	3	O	3.3V Regulated Output
AUX33	4	I	3.3V Auxiliary Supply Input
GND	5	I	Ground
GND	6	I	Ground
GND	7	I	Ground
GND	8	I	Ground

**Absolute Maximum Ratings**

- Main Supply Voltage,  $V_{(VCC50)}$  ..... -0.5 V~7V
- Standby Supply Voltage,  $V_{(VS50)}$  ..... -0.5 V~7V
- Auxiliary Supply Voltage,  $V_{(AUX33)}$  ..... -0.5 V~7V
- Output Current Limit,  $I_{(LIMIT)}$  ..... 1.5A
- Continuous Power Dissipation,  $P_d$  ( see Note 1 ) ..... 1.1W
- Electrostatic Discharge Susceptibility, Human Body Mode ..... 2kV
- Operating Ambient Temperature Range,  $T_C$  ..... 0 to +70
- Storage Temperature Range,  $T_{storage}$  ..... -45 to +125
- Operating Junction Temperature Range,  $T_J$  ..... -5 to +130
- Lead Temperature ( Soldering for 10 seconds ),  $T_{(LEAD)}$  ..... 260



Note 1 : The device deteriorates with increase in ambient temperature,  $T_C$ . See Thermal Information section.

### Recommended Operating Conditions

Parameter	Min	Typ	Max	Unit
5V Main Supply Input, VCC50	4.5	-	5.5	V
5V Standby Supply Input, VSB50	4.5	-	5.5	V
3.3V Auxiliary Supply Input, AUX33	3.0	-	3.6	V
Load Capacitance, $C_L$	4.23	4.70	5.17	$\mu$ F
Load Current, $I_L$	0	-	250	mA
Ambient Temperature, $T_C$	0	-	70	

### Electrical Characteristics Over Recommended Operating Free-Air Temperature, $T_C = 0$ to $70$ , $C_L = 4.7\mu$ F (Unless Otherwise Specified)

Parameter	Symbol	Test Condition	Min	Typ	Max	Unit
5V Inputs	VCC50 VSB50		4.5	5.0	5.5	V
3.3V Output	OUT33	$I_{out33} = 250$ mA	3.135	3.300	3.465	V
Line Regulation Voltage	$\Delta V_{O(\Delta VI)}$	VSB50 or VCC50 = 4.5V to 5.5V	-	2	-	mV
Load Regulation Voltage	$\Delta V_{O(\Delta IO)}$	20 mA < $I_L$ < 250 mA	-	40	-	mV
Quiescent Supply Current	$I_{50}$	From VCC50 VSB50 terminals, $I_L = 0$ mA to 250mA	-	1.0	3.0	mA
$I_{AUX}$	$I_{AUX}$	From AUX33 terminal, $I_L = 0$ A	-	1.0	3.0	mA
Out33 Load Current	$I_{L33}$		0.25	-	-	A
Output Current Limit	$I_{LIMIT}$	Out33 Output short to 0V	-	-	1.5	
Thermal Shutdown (Note 2)	$T_{TSD}$		150	-	180	
Thermal Hysteresis (Note 2)	$T_{hys}$		-	15	-	
Load Capacitance	$C_L$	Minimal ESR to insure stability of regulated output	-	4.7	-	$\mu$ F
Reverse Leakage Output Current	$I_{Ikg(REV)}$	Tested for grounded input AUX33, VSB50 or VCC50 = GND, Out33 = 3.3V	-	-	50	$\mu$ A
Threshold Voltage, Low	$V_{LO}$	VSB50 or VCC50	3.85	4.05	4.25	V
Threshold Voltage, High	$V_{HI}$	VSB50 or VCC50	4.1	4.3	4.5	V
Auxiliary Switch Resistance	$R_{(SWITCH)}$	VSB50 = VCC50 = 0V, AUX33 = 3.3V, $I_L = 150$ mA	-	-	0.4	$\Omega$
Thermal Impedance, Junction-to-Ambient (Note 3)	$R_{\theta JA}$	Without copper for heat spreading	-	100	-	/W
		With copper for heat spreading	-	70	-	

– 台灣類比科技股份有限公司 –  
– Advanced Analog Technology, Inc. –



Note 2 : Design targets only. Not tested in production.

Note 3 : Please refer to "Thermal Information"

## Block Diagram

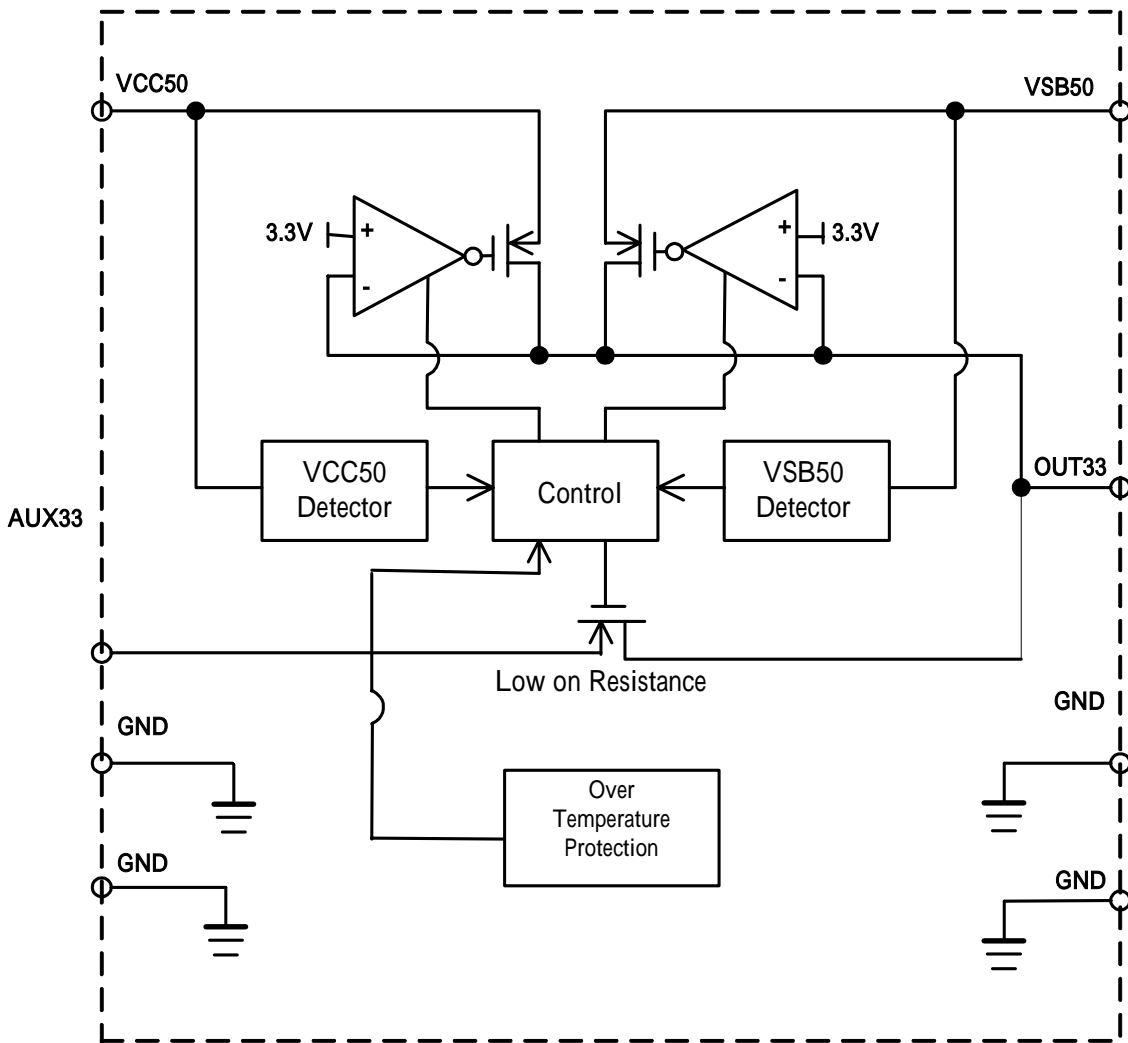



Typical Characteristics

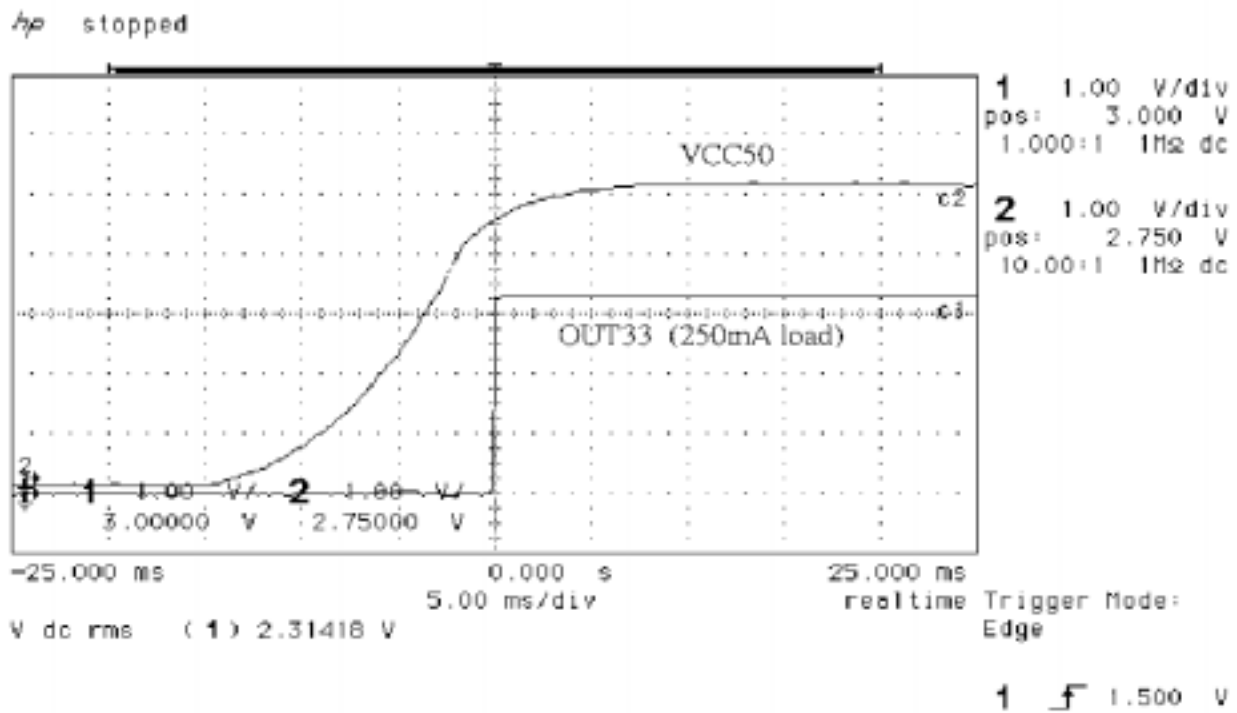

Fig. 1. 3.3V VCC50 Cold Start

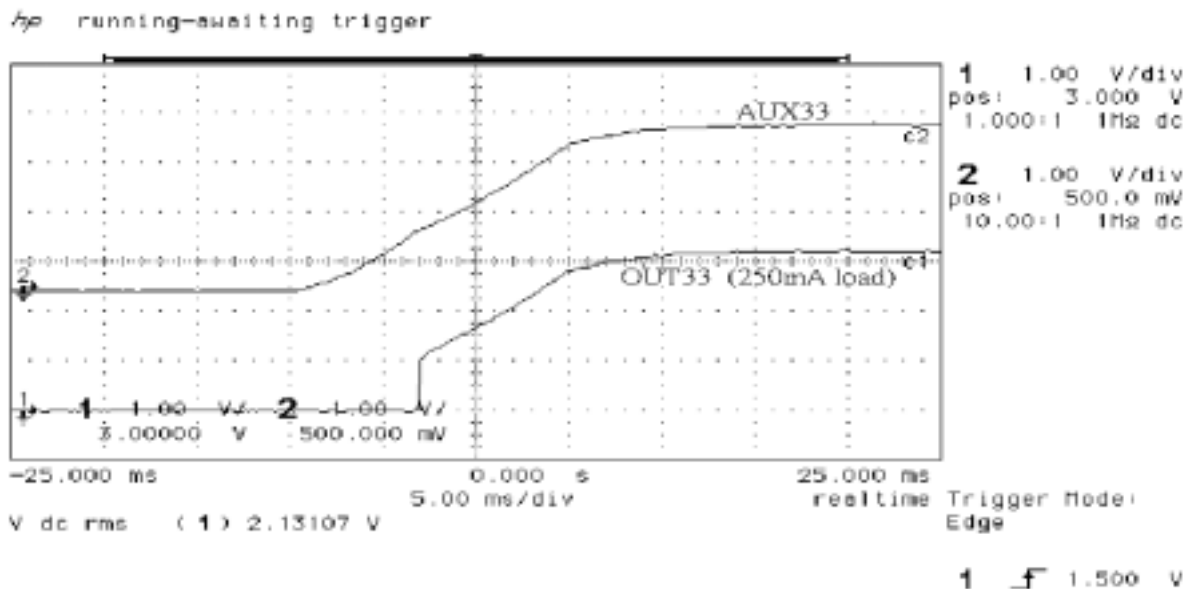

Fig. 2. 3.3V VUX33 Cold Start

– 台灣類比科技股份有限公司 –  
– Advanced Analog Technology, Inc. –



Typical Characteristics

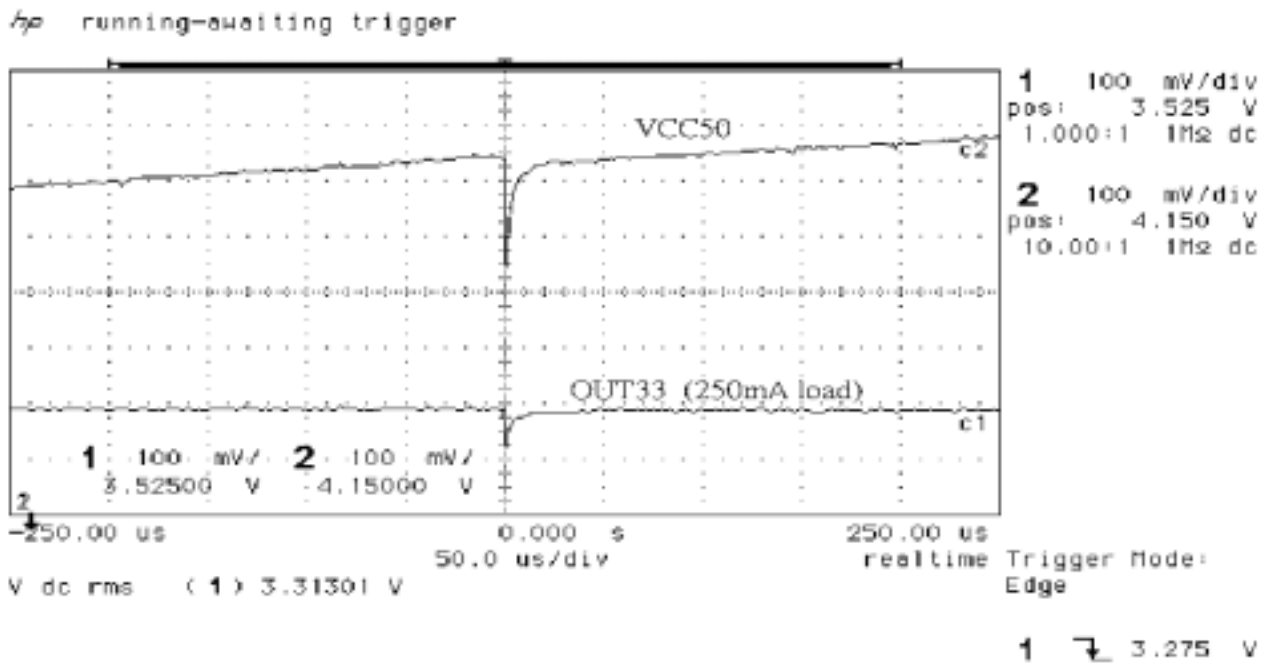

Fig. 3. 3.3V VCC50 Power Up (VSB50=5V)

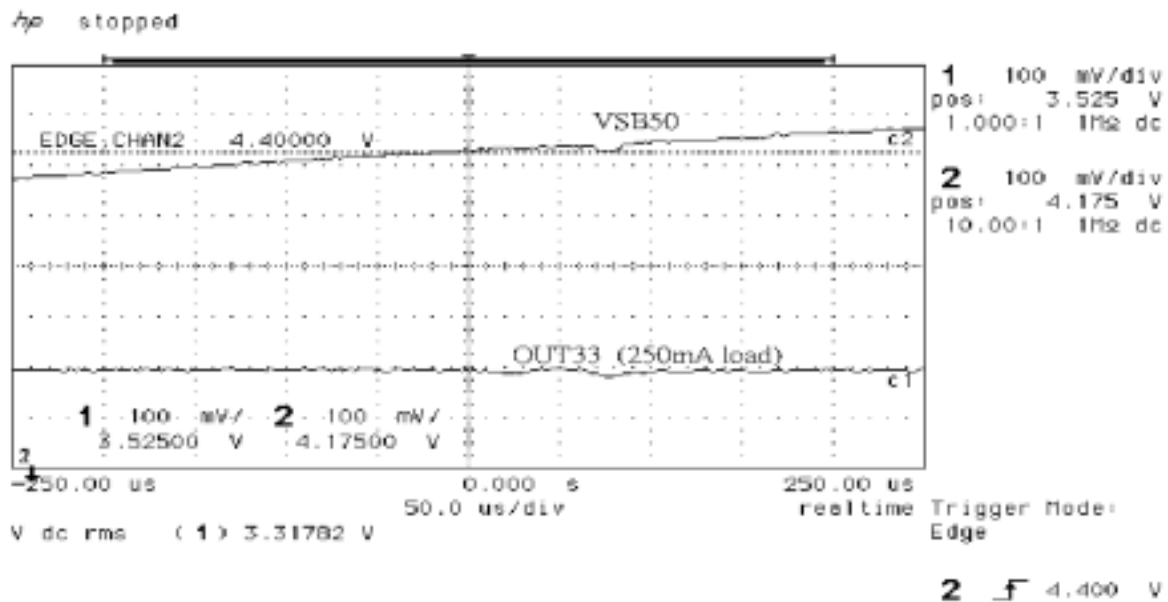

Fig. 4. 3.3V VCC50 Power Up (AUX33=3.3V)

– 台灣類比科技股份有限公司 –  
– Advanced Analog Technology, Inc. –



Typical Characteristics

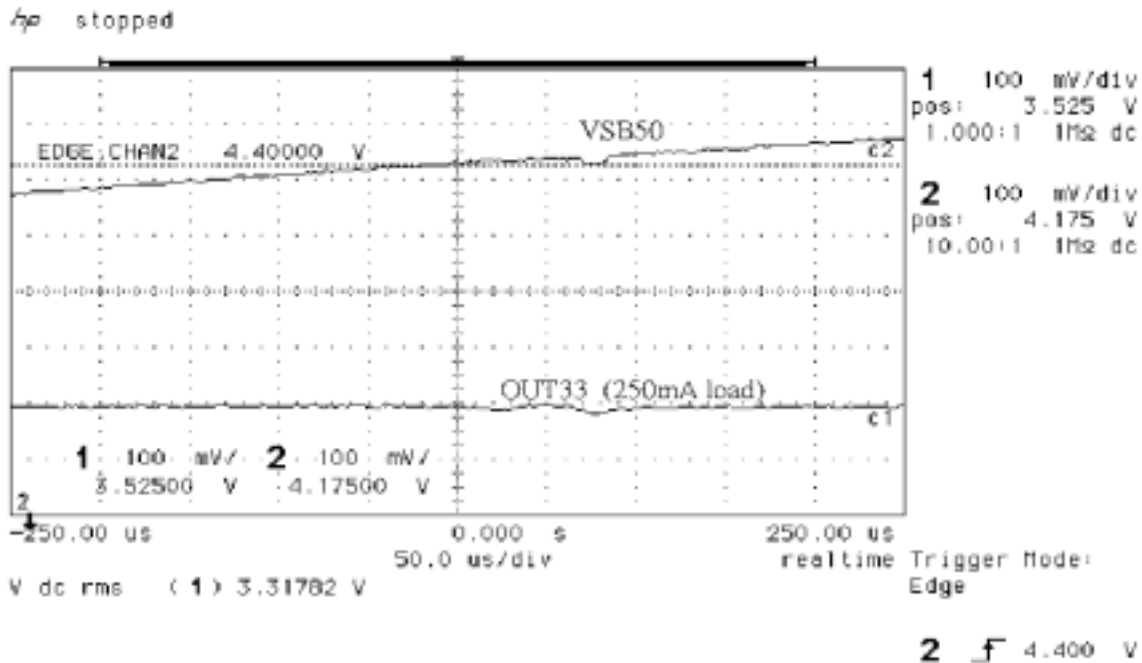

Fig. 5. 3.3V VSB50 Power Up (AUX33=3.3V)

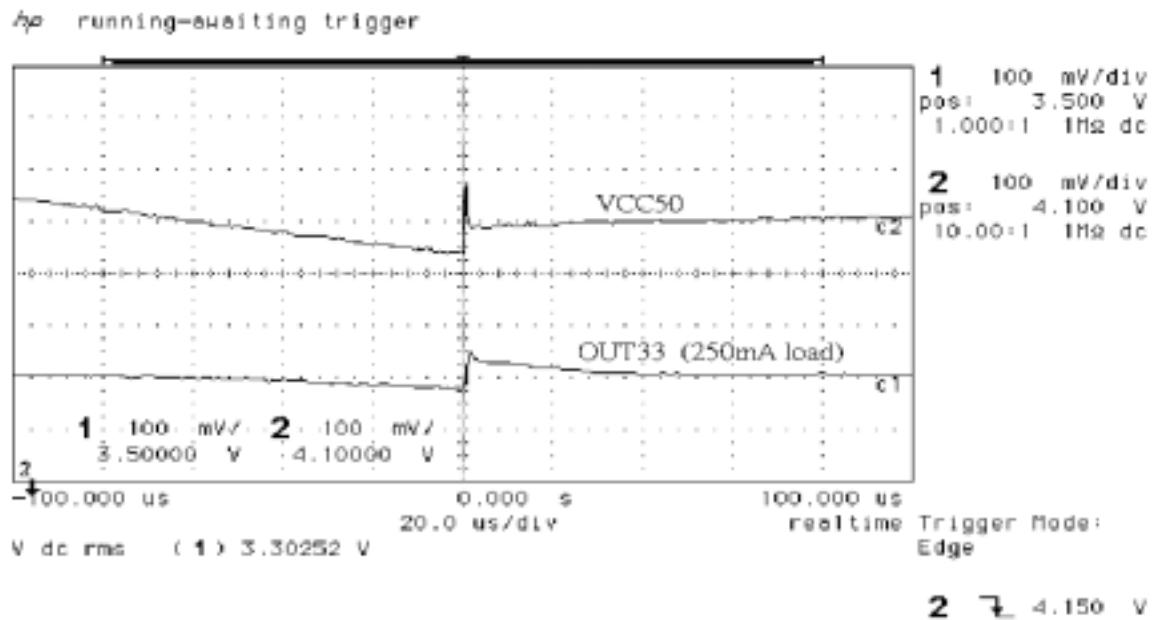

Fig. 6. 3.3V VCC50 Power Down (VSB=5V)

– 台灣類比科技股份有限公司 –  
– Advanced Analog Technology, Inc. –





Typical Characteristics

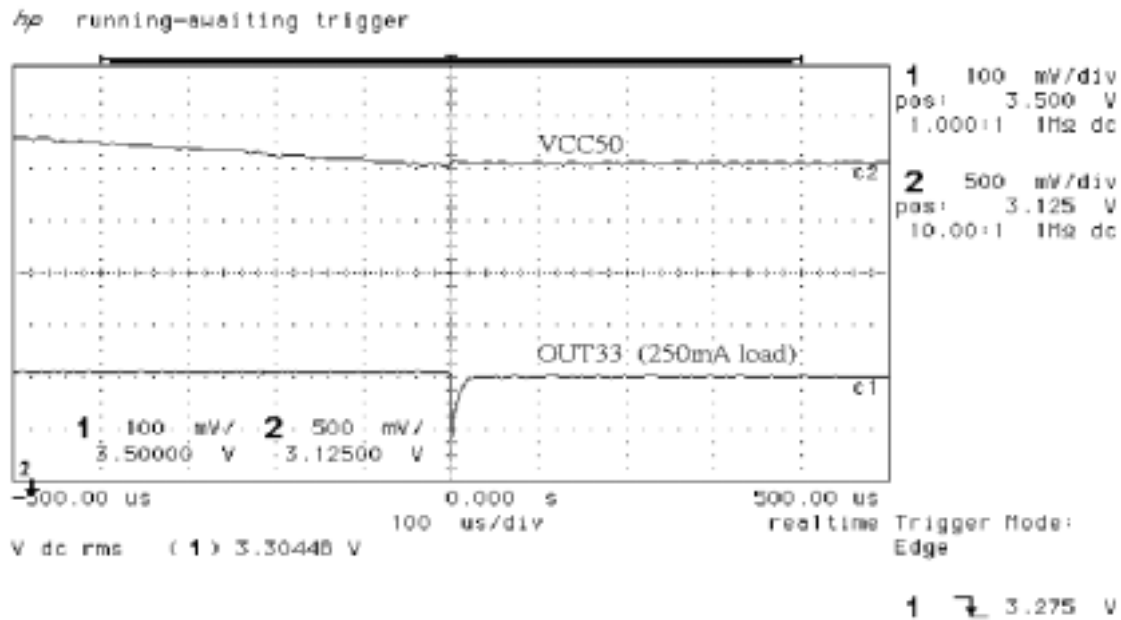

Fig. 7. 3.3V VCC50 Power Down (AUX33=3.3V)

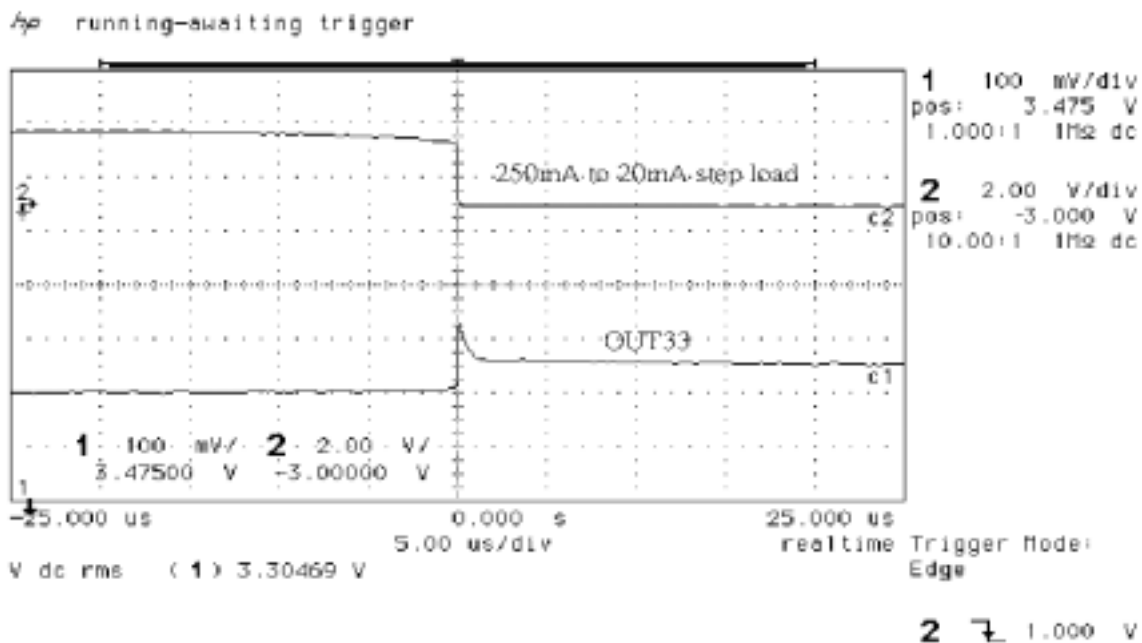

Fig. 8. 3.3V Load Transient Response Falling.

– 台灣類比科技股份有限公司 –  
– Advanced Analog Technology, Inc. –



Typical Characteristics

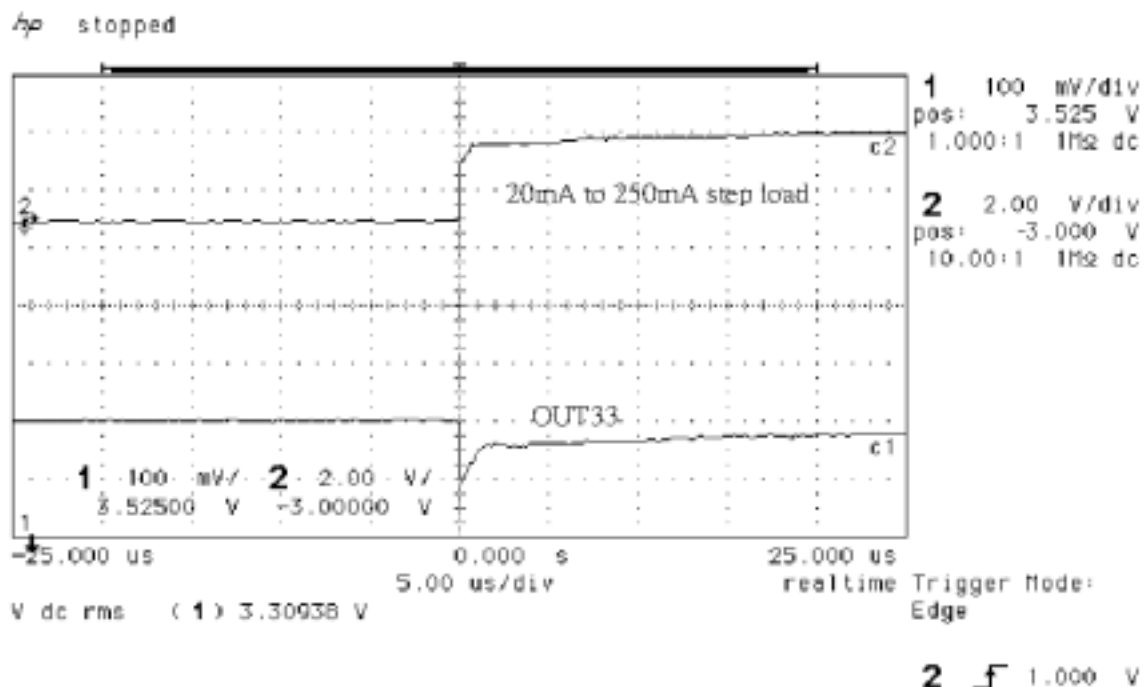

Fig. 9. 3.3V Load Transient Response Rising



### Thermal Information

To ensure reliable operation of the device, the junction temperature of the output device must be within the safe operating area ( SOA ). This is achieved by having a means to dissipate the heat generated from the junction of the output structure. There are two components that contribute to thermal resistance. They consist of two paths in series. The first path is the junction to case thermal resistance,  $R_{JC}$ ; the second path is the case to ambient thermal resistance,  $R_{CA}$ . The overall junction to ambient thermal resistance,  $R_{JA}$ , is determined by :

$$R_{JA} = R_{JC} + R_{CA}$$

Package and board layout incorporated in the application determines the ability to efficiently dissipate the heat from the junction. The operating junction temperature is determined by the operation ambient temperature,  $T_C$ , and the junction power dissipation,  $P_J$ .

The junction temperature,  $T_J$ , is equal to the following thermal equation :

$$T_J = T_C + P_J ( R_{JC} ) + P_J ( R_{CA} )$$

$$T_J = T_C + P_J ( R_{JA} )$$

This particular application uses the 8-pin SOIC package with standard lead frame with a dedicated ground terminal. Hence, the maximum power dissipation allowable for an operating ambient temperature of 70 , and a maximum junction temperature of 150 is determined as :

$$P_J = ( T_J - T_C ) / R_{JA}$$

$$P_J = ( 150 - 70 ) / 70 = 1.1W$$

Worst case maximum power dissipation is determined by :

$$P_d = ( 5.5 - 3.135 ) \times 0.25 = 0.591W$$

Normal operating maximum power dissipation is :

$$P_d = ( 5 - 3.3 ) \times 0.25 = 0.425W$$

Note: The thermal characteristics of the AAT1203 were measured using a double-sided board with two square inches of copper area connected to the GND pins for "heat spreading". The use of multi-layer board construction with power planes will further enhance the thermal performance of the package.



### Thermal Information (Cont.)

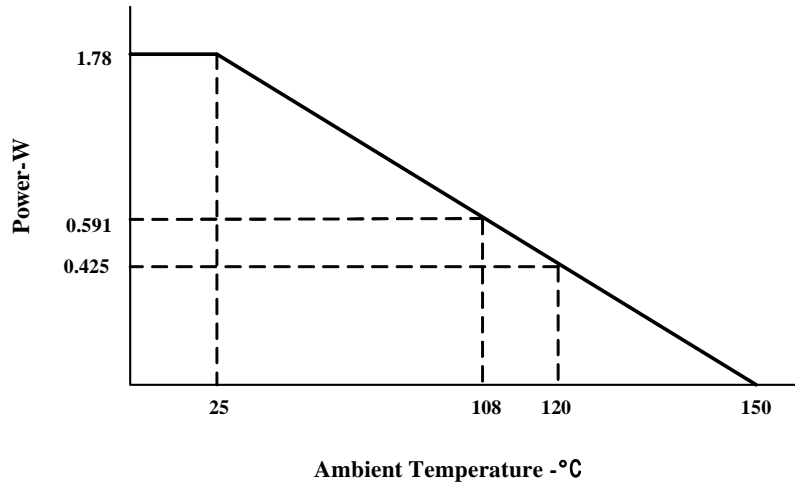

NOTE: These curves are to be used for guideline purposes only. For a particular application, a more specific thermal characterization is required.

Power Dissipation Derating Curves

### Application Information

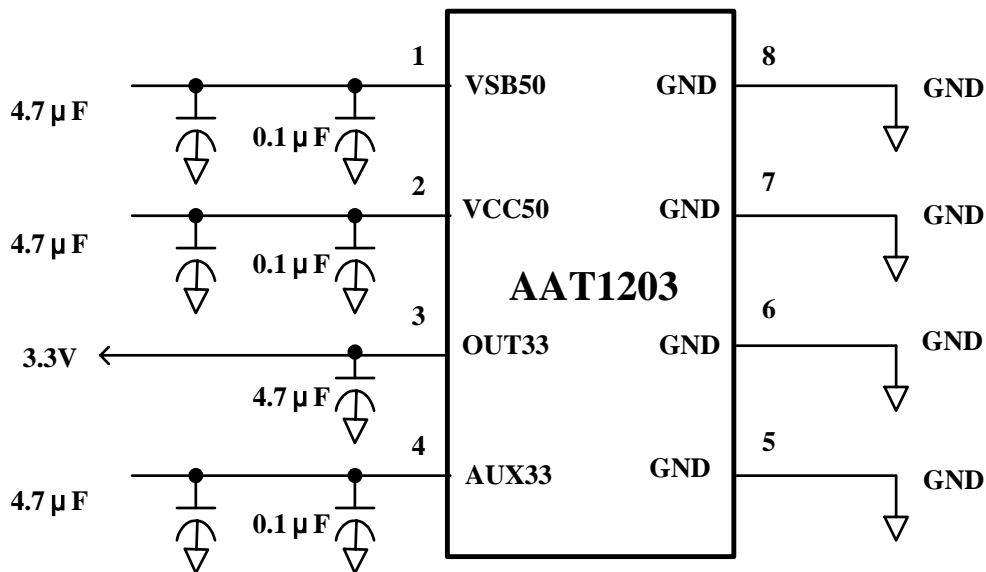



**Package Dimension**

**8-Pin SOP**

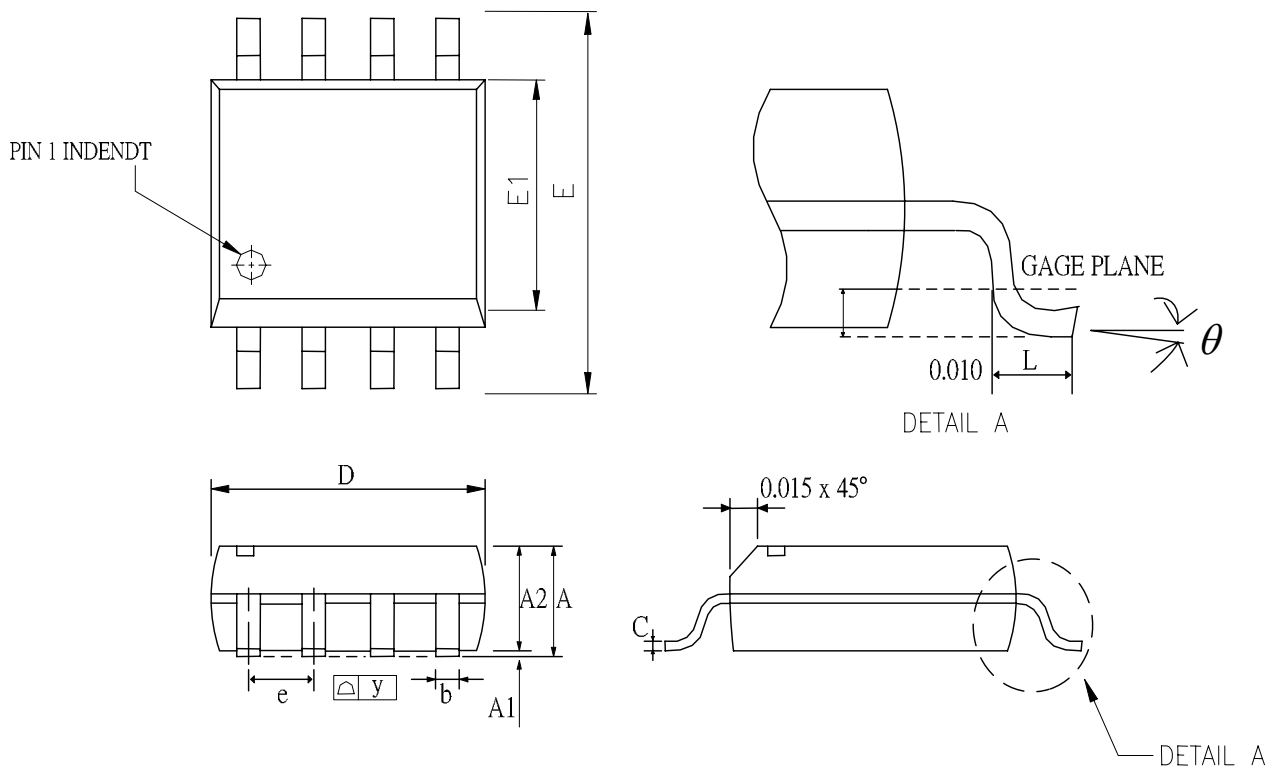

SYMBOLS	DIMENSIONS IN MILLIMETERS			DEMINSIONS IN INCHES		
	MIN	TYP	MAX	MIN	TYP	MAX
A	1.47	1.60	1.73	0.058	0.063	0.068
A1	0.10	---	0.22	0.004	---	0.008
A2	---	1.45	---	---	0.057	---
b	0.33	0.41	0.51	0.013	0.016	0.020
C	0.19	0.20	0.25	0.0075	0.008	0.0098
D	4.80	4.85	4.95	0.189	0.191	0.195
E	5.80	6.00	6.20	0.228	0.236	0.244
E1	3.80	3.90	4.00	0.150	0.154	0.157
e	---	1.27	---	---	0.050	---
L	0.38	0.71	1.27	0.015	0.028	0.050
y	---	---	0.076	---	---	0
θ	0	---	0	0	---	0



**Tape and Reel**  
**8-Pin SOP**

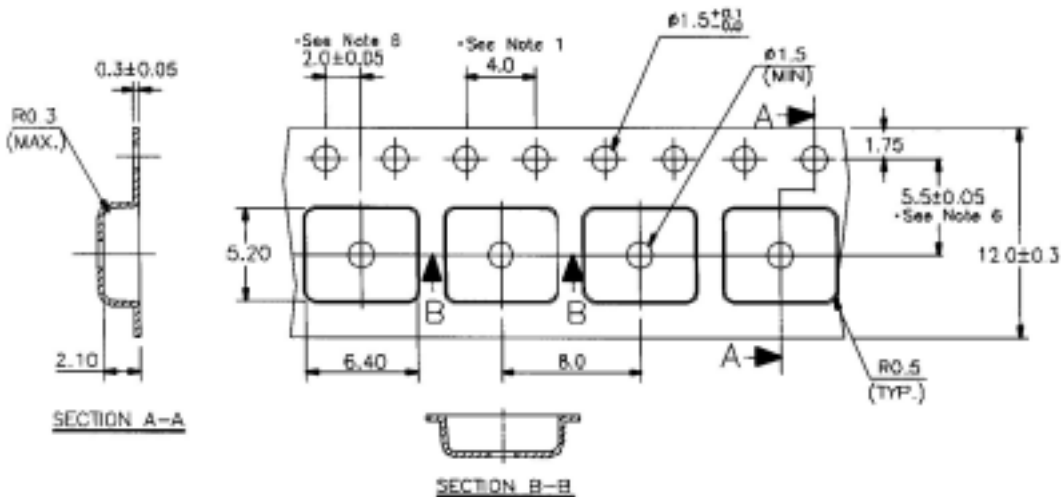
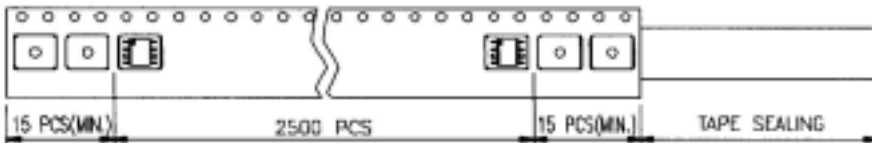
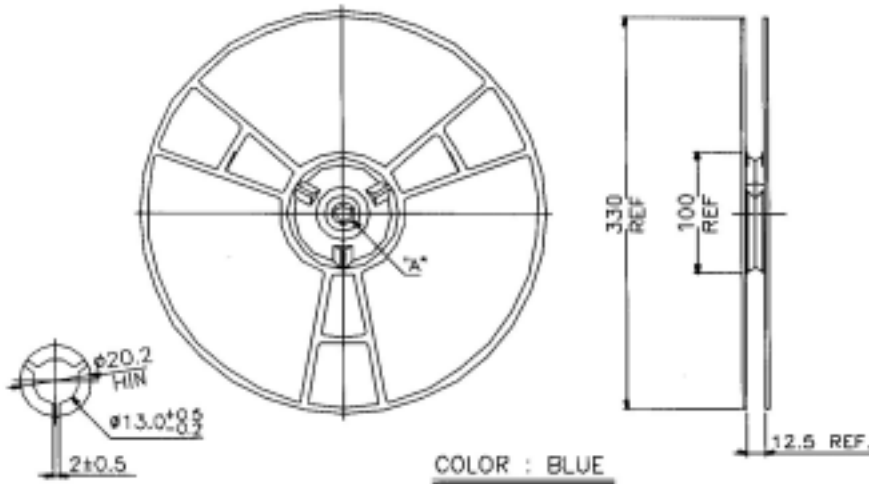



## Tape and Reel

### 8-Pin SOP (Cont.)

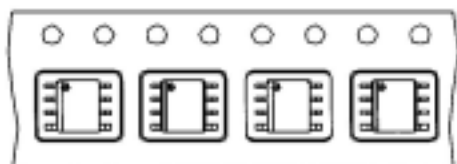

SOP 8N(150mil)

#### NOTE:

1. 10 SPROCKET HOLE PITCH CUMULATIVE TOLERANCE  $\pm 0.2$  MILLIMETERS.
2. CAMBER NOT TO EXCEED 1 MILLIMETER IN 100 MILLIMETERS
3. MATERIAL: ANTI-STATIC BLACK ADVANTEK POLYSTYRENE.
4.  $A_0$  AND  $B_0$  ARE MEASURED ON A PLANE 0.3 MILLIMETERS ABOVE THE BOTTOM OF THE POCKET.
5.  $K_0$  IS MEASURED FROM A PLANE ON THE INSIDE BOTTOM OF THE POCKET TO THE TOP SURFACE OF THE CARRIER.
6. POCKET POSITION RELATIVE TO SPROCKET HOLE IS MEASURED AS TRUE POSITION OF POCKET, NOT POCKET HOLE.

## Part Marking

### SOP8 Top Marking

AAT1203  
XXXXXX

### SOP8 Back Marking

YYWW



**Ordering Information**

**AAT xxxxx-xx-x**

AAT Part Number

Package Code 1  
8-Pin SOP: S

Package Code 2  
T=Taping Reel  
Blank=Tube or Tray

Remark:  
T=Taping Reel  
PS. 8-Pin SOP→2,500pcs/reel

Blank=Tube  
PS. 8-Pin SOP→98pcs/tube