

# ACX307AK ACX308AK

The 2.5-type color LCD panel is widely used as the monitor in digital video cameras.

Sony has already released the 200K-dot ACX300CK high-resolution low-temperature polycrystalline silicon TFT LCD. Now, Sony is expanding its product line by releasing the 120K-dot ACX307AK and the 60K-dot ACX308AK LCD panels, which provide identical functionality and have the same external dimensions as the ACX300CK.

- High transmittance achieved by using low-temperature polycrystalline silicon TFT technology.  
ACX307AK: 9.0 %  
ACX308AK: 10.5 %
- Low power consumption: 50 mW (When a 12 V power supply is used)
- Analog full color display
- Wide-screen display function
- Up/down and/or right/left inversion functions

By releasing the new ACX307AK and the ACX308AK products in addition to the previously released 200K-dot high-resolution ACX300CK, Sony now provides a product line of three 2.5-type color LCD panels for AV applications that are compatible in size and shape but offer differing numbers of active dots. This allows our customers to expand their end-product lines while using only low-temperature polycrystalline silicon LCD panels, and increases flexibility in end product design. Furthermore, the panel external size can also be matched to that of amorphous silicon LCD panels, thus allowing these products to flexibly respond to needs for interchangeability.

## ■ High Optical Transmittance Achieved

As a result of optimal pixel design in the context of Sony's unique low-temperature polycrystalline silicon TFT technology, the ACX307AK and the ACX308AK achieve the high aperture ratios of 73% and 81%, respectively. Additionally, Sony has adopted a new pixel structure that significantly increases the optical transmittance as compared to conventional amorphous silicon LCD panels of which the same number of pixels. In particular, the ACX307AK achieves 9.0% and the ACX308AK achieves 10.5%. This means that these are "even brighter" LCD panels. (See table 1.)

## ■ Extensive Functionality and Improved Ease of Use

In addition to the up/down and/or right/left inversion and wide display functions provided by conventional products, Sony has developed and adopted voltage step-up power supply and negative voltage generation circuits to reduce the external power supply and to improve the ease of use of these products. (See figure 1.) Sony is also planning to develop a new single chip IC that integrates both timing generator and control functions on the same chip to make drive circuit design far simpler. (See figure 2.)

## V O I C E

Although up to now we have focused on high-resolution devices in our low-temperature polycrystalline silicon LCDs, in our current project, we developed popular devices, the ACX307AK and the ACX308AK. These devices make superlative low-temperature polycrystalline silicon LCD panels available for a wide range of products, from popular models to high-class models.



*New  
Products*

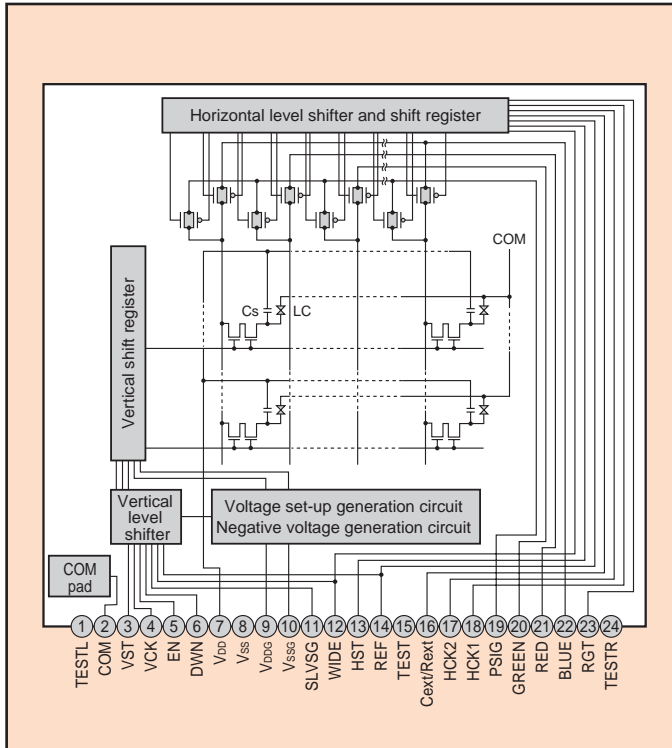

■ Figure 1 Panel Block Diagram

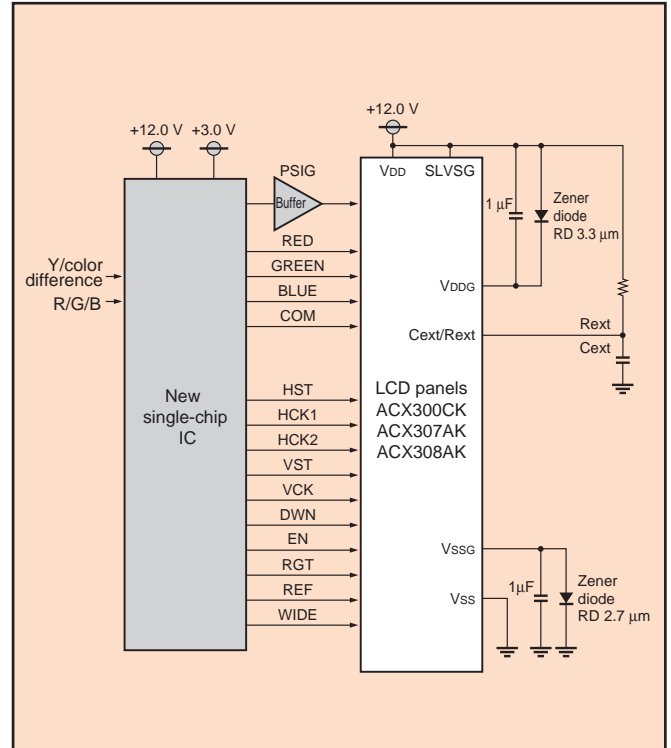

■ Figure 2 System Block Diagram

■ Table 1 6.25 cm (2.5-type) Transmissive LCD Panel

Module structure	ACX300CK	ACX307AK	ACX308AK
Screen size	6.25 cm diagonal	6.25 cm diagonal	6.25 cm diagonal
Number of active dots (H × V)	200,000 (880 × 228)	120,000 (560 × 220)	60,000 (280 × 220)
Screen aspect ratio	4 : 3	4 : 3	4 : 3
Pixel arrangement	RGB delta	RGB delta	RGB delta
Dot pitch (μm)	56.75 × 163.75	90 × 170	179 × 170
Aperture ratio (%)	67	73	81
Optical transmittance (%)	8.2	9.0	10.5
Contrast ratio	200 : 1	200 : 1	200 : 1
Supply voltage (V)	12	12	12
Display method	NTSC/PAL	NTSC/PAL	NTSC/PAL
Panel dimensions (W × H × t (mm))	61.6 × 49.3 × 2.2	61.6 × 49.3 × 2.2	61.6 × 49.3 × 2.2
Power consumption (W)	0.06	0.06	0.06
Number of colors	Analog full color	Analog full color	Analog full color