

AZ DISPLAYS, INC.

COMPLETE LCD SOLUTIONS

SPECIFICATIONS FOR LIQUID CRYSTAL DISPLAY

PART NUMBER:

AGM 1232E SERIES

DATE:

FEBRUARY 10, 2001

AGM1232E SERIES GRAPHIC MODULE

1.0 MECHANICAL SPECS

1. Item	Description
2. Overall Module Size	66.1mm(W) x 27.3mm(H) x max 8.5mm(D)
3. Dot Size	0.40mm(W) x 0.45mm(H)
4. Dot Pitch	0.44mm(W) x 0.49mm(H)
5. Duty	1/32
6. Controller IC	SED1520FOA/DOA
7. LC Fluid Options	STN, FSTN
8. Polarizer Options	Reflective, Transflective, Transmissive
9. Backlight Options	EL
10. Temperature Range Options	Standard (0°C ~ 50°C), Wide (-20°C ~ 70°C)

2.0 ABSOLUTE MAXIMUM RATINGS

Item	Symbol	Min	Typ	Max	Unit
Operating temperature (Standard)	Top	0	-	50	°C
Storage temperature (Standard)	Tst	-20	-	70	°C
Operating temperature (Wide temperature)	Top	-20	-	70	°C
Storage temperature (Wide temperature)	Tst	-30	-	80	°C
Input voltage	Vin	Vss		Vdd	V
Supply voltage for logic	Vdd- Vss	-0.3	-	7.0	V
Supply voltage for LCD drive	Vdd- Vee	5.0	6.5	9.5	V

AGM1232E SERIES GRAPHIC MODULE

3.0 ELECTRICAL CHARACTERISTICS

Item	Symbol	Condition	Min	Typ	Max	Unit
Input voltage (high)	V _{ih}	H level	3.5	-	V _{dd}	V
Input voltage (low)	V _{il}	L level	0	-	1.5	V
Recommended LC Driving Voltage (Standard Temp)	V _{dd} - V _{ee}	0°C	-	7.8	10.0	V
		25°C	-	6.5	-	
		50°C	4.3	5.5	-	
Recommended LC Driving Voltage (Wide Temp)	V _{dd} -V _{ee}	-20°C	-	8.5	10.8	V
		0°C	-	7.8	-	
		50°C	4.3	5.5	-	
		70°C	3.5	4.8	-	
Power Supply Current	I _{dd}	V _{dd} =5.0V	-	-	13.0	mA
LED Power Supply Voltage	V _{fled}	R=6.8Ω	-	4.4	5.0	V
LED Power Supply Current	I _{fled}	R=6.8Ω	-	300	420	mA

4.0 OPTICAL CHARACTERISTICS

Item		Cr (Contrast Ratio)		θ (Viewing Angle)		φ (Viewing Angle)	
		25°C		25°C		25°C	
		MIN.	TYP.	MIN	TYP.	MIN	TYP.
R	A	2.8	3.05	80°	85°	-	35°
	B	7.10	7.70	80°	85°	-	35°
	C	-	-	-	-	-	-
S	A	2.49	2.99	80°	85°	-	35°
	B	7.05	7.55	80°	85°	-	35°
	C	-	-	-	-	-	-

Note:

R: Reflective
 S: Transflective
 A: STN Gray
 B: STN Yellow
 C: FSTN

At: φ = 0°, θ = 0°

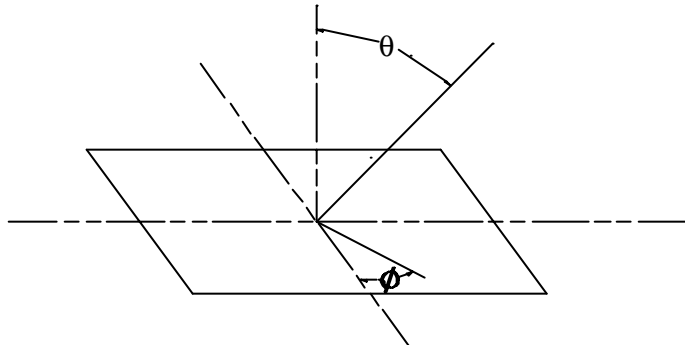

AGM1232E SERIES GRAPHIC MODULE

Item	Symbol	Condition	Min	Typ	Max	Unit
Response time (rise)	Tr	25 °C	-	80	160	ms
Response time (fall)	Tf	25 °C	-	50	100	ns

5.0 BLOCK DIAGRAM

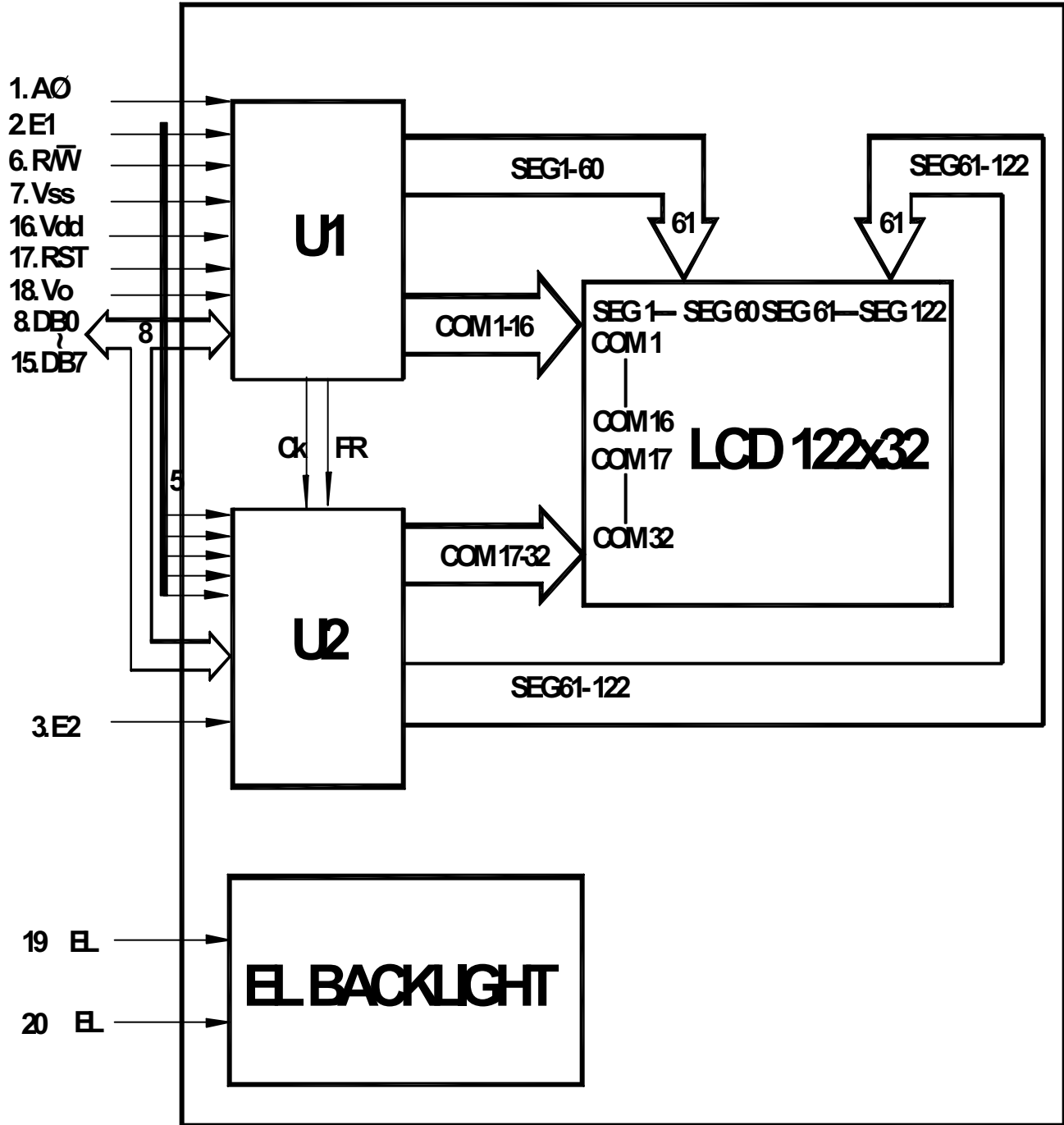

AGM1232E SERIES GRAPHIC MODULE

6.0 PIN ASSIGNMENT

Pin No.	Symbol	Function	Level
1	AØ	Instruction/Data	H/L
2	E1	Enable for IC1	H/L
3	E2	Enable for IC2	H/L
4	NC	No Connect	
5	NC	No Connect	
6	R/W	H: Data read L: Data write	H/L
7	Vss	Ground	-
8	DB0	Data bit 0	H/L
9	DB1	Data bit 1	H/L
10	DB2	Data bit 2	H/L
11	DB3	Data bit 3	H/L
12	DB4	Data bit 4	H/L
13	DB5	Data bit 5	H/L
14	DB6	Data bit 6	H/L
15	DB7	Data bit 7	H/L
16	Vdd	Power Supply For Logic Circuit	
17	RST	Reset	
18	Vee	Power Supply For LCD Driving	
19	EL	Power Supply for EL	-
20	EL	Power Supply for EL	-

7.0 POWER SUPPLY

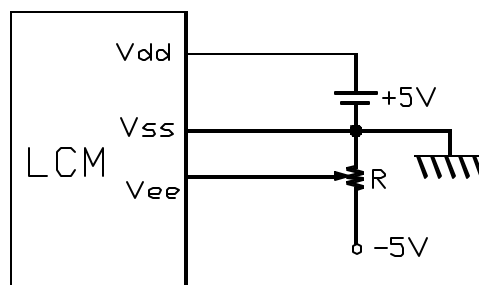

AGM1232E SERIES GRAPHIC MODULE

8.0 TIMING CHARACTERISTICS

Item	Symbol	Test Condition	Min.	Typ.	Max.	Unit
System cycle time	t_{CYC6}	Fig. a, Fig. b	1000	-	-	ns
Address setup time	t_{AW6}	Fig. a, Fig. b	20	-	-	ns
Address hold time	t_{AH6}	Fig. a, Fig. b	10	-	-	ns
Data hold time	t_{DH6}	Fig. a	10	-	-	ns
Data setup time	t_{DS6}	Fig. a	80	-	-	ns
Output disable time	t_{OH6}	CL=100 pF	10	-	60	ns
Access time	t_{ACC6}		-	-	90	
Enable pulsewidth	Read	T_{EW}	100			ns
	Write		80			ns
Rise and fall time	T_r, T_f	Fig. a, Fig. b	-	-	15	ns

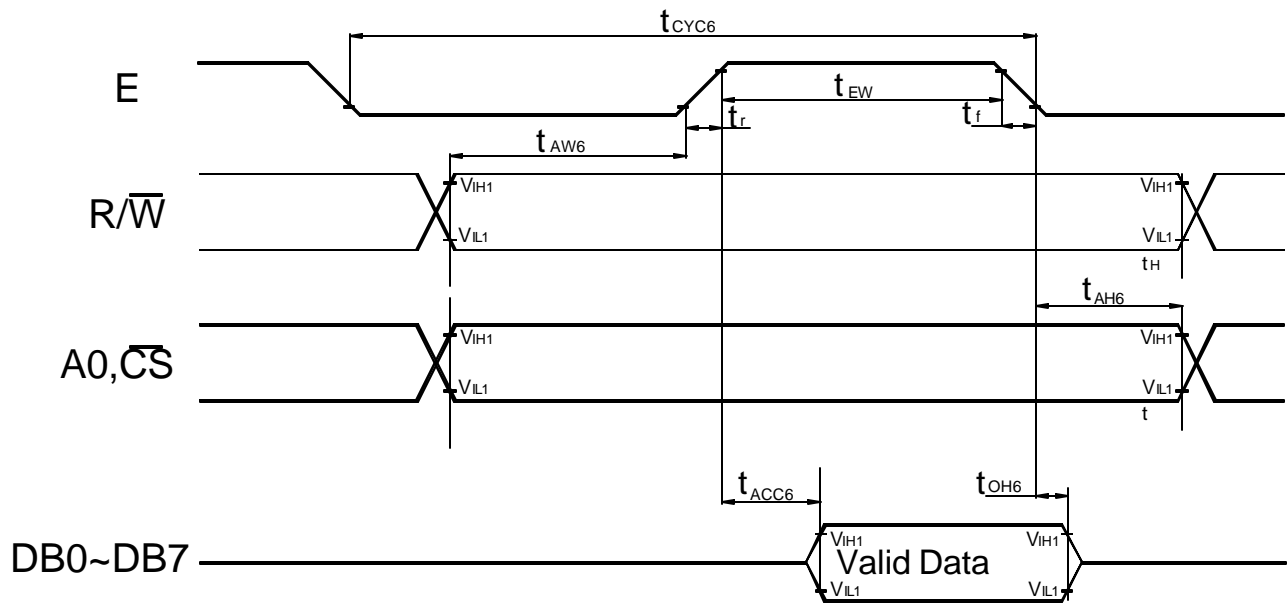

Fig. a Interface timing (data Read)

AGM1232E SERIES GRAPHIC MODULE

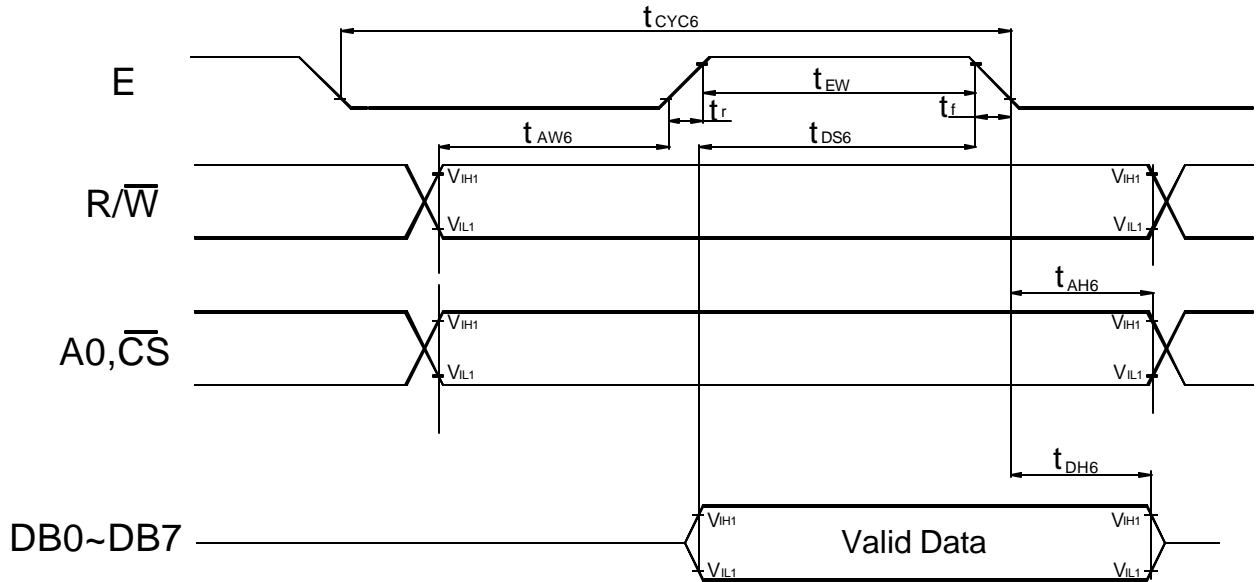

Fig. b Interface timing (data Write)

9.0 RELIABILITY TEST

Storage Condition	Content	Evaluations and Assessment*			
		Current Consumption	Oozing	Contrast	Other Appearances
Operation at high temperature and humidity	40° C, 90% RH, 240hrs	Twice initial value or less	none	More than 80% of initial value	No abnormality
High temperature storage	60° C, 240hrs	Twice initial value or less	none	More than 80% of initial value	No abnormality
Low temperature storage	-20° C, 240hrs	Twice initial value or less		More than 80% of initial value	No abnormality

*Evaluations and assessment to be made two hours after returning to room temperature (25° C ± 5° C).

*The LCDs subjected to the test must not have dew condensation.

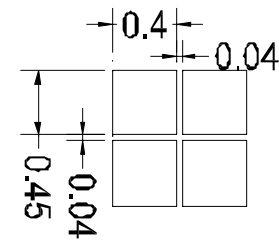
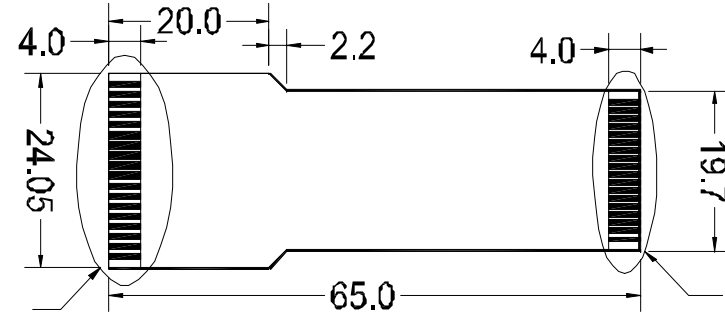
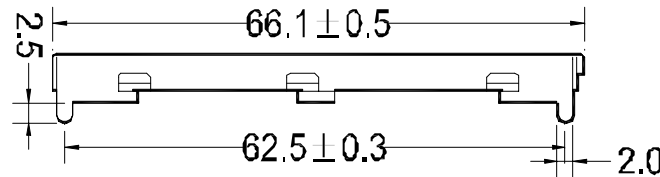
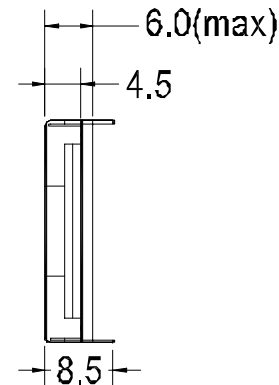
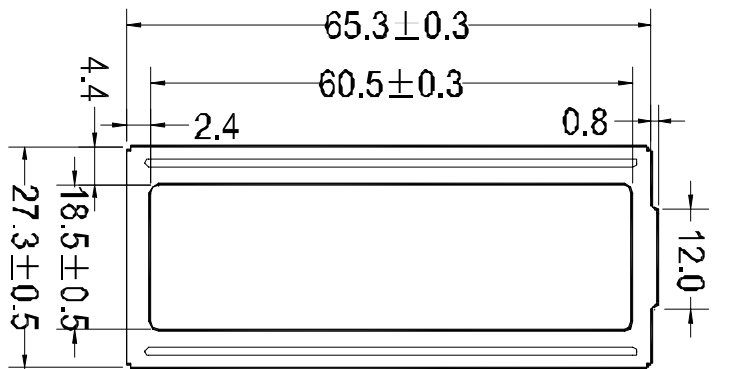
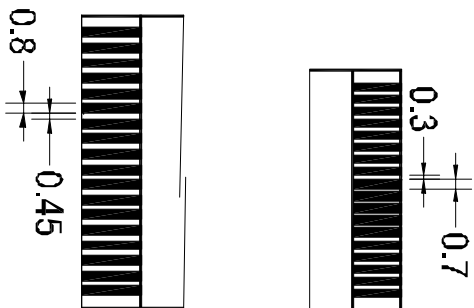

Display Pattern

PIN	SYMBOL	FUNCTION
1	A0	INSTRUCTION/DATA
2	E1	ENAB_E FOR IC1
3	E2	ENAB_E FOR IC2
4	NC	No Connect
5	NC	No Connect
6	R/W	READ/WRITE SINGAL
7	Vss	POWER SUPPLY (GND)
8	DB0	DATA BUS LINE
9	DB1	
10	DB2	
11	DB3	
12	DB4	
13	DB5	
14	DB6	
15	DB7	
16	Vdd	POWER SUPPLY (+5V)
17	RES	RESET
18	Vo	POWER SUPPLY FOR LCD DRIVING
19	EL	POWER SUPPLY EL
20	EL	POWER SUPPLY EL

TITLE: AGM1232E SERIES LCD MODULE		AZ DISPLAYS, INC.			
REVISION RECORD		NAME	DATE	DRAWING NO. AGM1232E-1 CM-01	DRAWN BY:
1					CHECKED BY:
2					APPROVED BY:
3				REVISION: VER.1	
4					
					UNIT: MM
					SCALE:

AGM1232E SERIES GRAPHIC MODULE

11.0 RELATION BETWEEN DISPLAY PATTERN AND DRIVERS

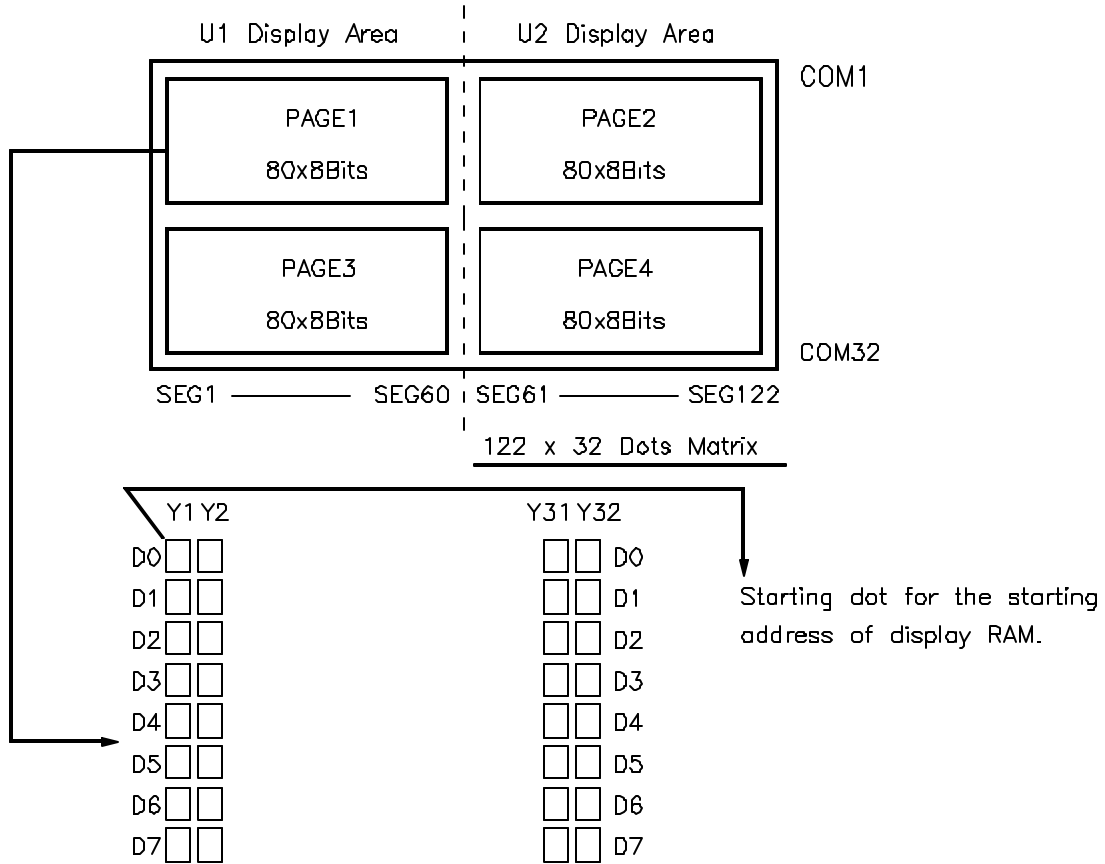

Each segment driver has 4 pages RAM, and each page has 80x8 bits RAM. D0~D7 are 8 bits transmitted data, where D0 is LSB and D7 is MSB.

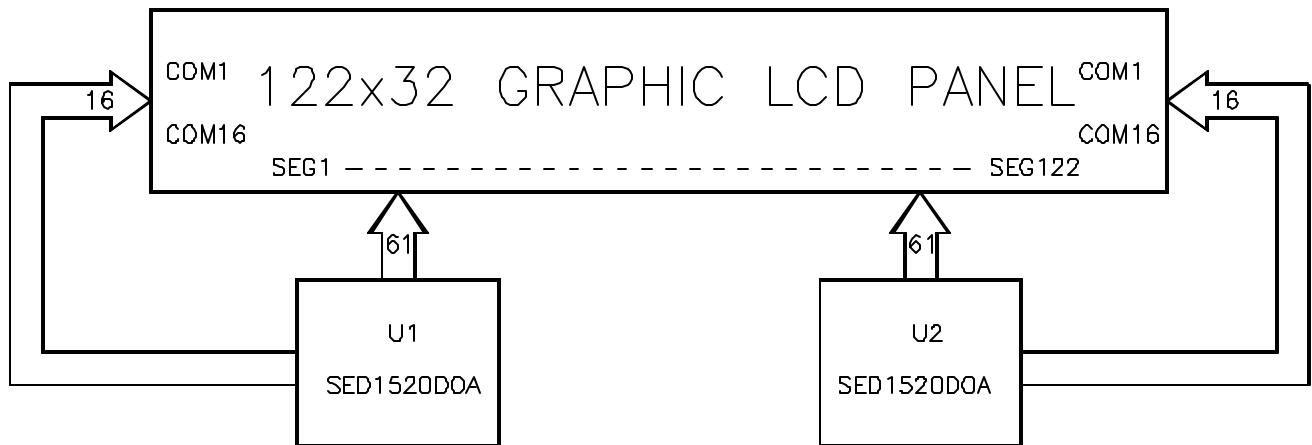

AGM1232E SERIES GRAPHIC MODULE

12.0 DISPLAY CONTROL INSTRUCTION

The display control instructions control the internal state of the SED1520DOA/FOA. Instructions are received from MPU to SED1520DOA/FOA for the display control.

INSTRUCTION	A0	RD	R/W	DB7	DB6	DB5	DB4	DB3	DB2	DB1	DB0	DESCRIPTION
Display ON/OFF	0	1	0	1	0	1	0	1	1	1	1/0	Turns display on or off. 0: OFF. 1:ON
Set Page Address	0	1	0	1	0	1	1	1	0	Page (0~3)		Sets display RAM Page in Page address register
Set Column (Segment address)	0	1	0	0	Column address (0~79)							Sets display RAM column address in column address register
Display Start Line	0	1	0	1	1	0	Display start line (0~31)					Indicates the display data RAM displayed at the top of the screen.
Status Read	0	0	1	BUSY	ADC	ON/OFF	RESET	0	0	0	0	Reads the following status: BUSY 0: Ready 1: Busy ADC 1: CW output 0: CCW output ON/OFF 0: Display on 1: Display off RESET 0: Normal 1: Being Reset
Write Display Data	1	1	0	Write Data								Writes data DB0~DB7 from bus into display data RAM.
Read Display Data	1	0	1	Read Data								Reads data DB0~DB7 from display data RAM onto the data bus.
Select ADC	0	1	0	1	0	1	0	0	0	0	0/1	0: CW output, 1: CCW output
Static drive ON/OFF	0	1	0	1	0	1	0	0	1	0	0/1	1: Static drive, 0: Normal driving
Select duty	0	1	0	1	0	1	0	1	0	0	0/1	Select LCD duty cycle 1:1/32, 0: 1/16
Read-Modify-Wreti	0	1	0	1	1	1	0	0	0	0	0	Read-Modify-write ON
END	0	1	0	1	1	1	0	1	1	1	0	Read-Modify-write OFF
Reset	0	1	0	1	1	1	0	0	0	1	0	Software reset