



AK61584

Dual Low Power T1/E1 Line Interface

Features

- Provides Dual Analog PCM Line Interface for short-haul, T1 and E1 applications
- Jitter Tolerance: Compliant with AT&T62411 TR-NWT-000499 Category I, II ITU-T G.823
- Transmitter Pulse Shape: Compliant with AT&T62411, CB119, TR-NWT-000499, ITU-T G.703
- Jitter Transfer: AT&T62411, ITU-T G.736
- Operating mode fully software configurable. No external quartz crystal is required.
- Support of JTAG boundary scan

- Low Power Consumption
- 3.3Volt operation
- Small Plastic Package 64pin LQFP(10*10* 1.4mm)

General Description

The AK61584 is a universal line interface for T1/E1 applications, designed for high-volume cards where low power, high density and universal operation is required. One board design can support all T1/E1 modes.

The AK61584 is a low-power CMOS device available in 3.3 Volt.

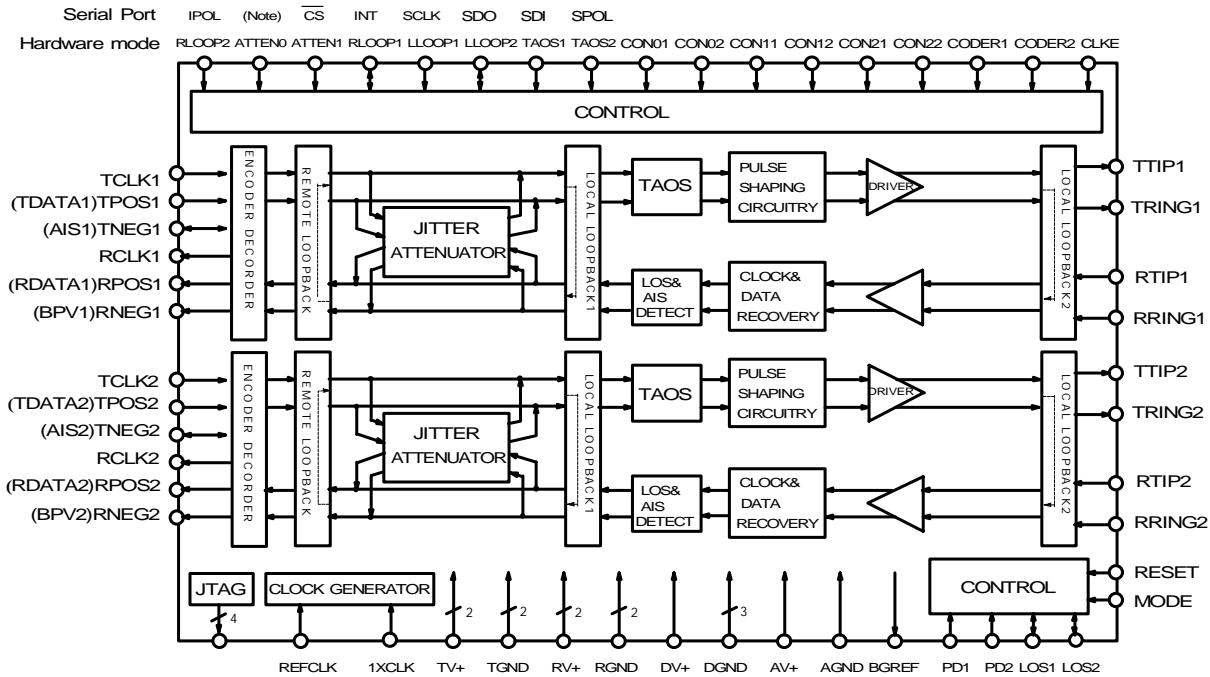

Note) In host mode, this pin must be tied to GND.

Preliminary Product Information

This document contains information for a new product. AKM reserves the right to modify this product without notice.

Table of Contents

Block Diagram.....	1
Specifications	
Absolute Maximum Ratings	3
Recommended Operating Conditions	3
Digital Characteristics	4
Analog Specifications	
Receiver.....	4
Jitter Attenuator	4
Transmitter	5
Switching Characteristics	
T1 Clock/Data	6
E1 Clock/Data	6
Serial Port.....	8
JTAG	9
General Description	
Overview.....	10
Operating Options	11
Overview of Applications.....	12
Transmitter	13
Receiver	15
Jitter Attenuator.....	16
Coder Mode	17
Reference Clock.....	17
Loopbacks	17
Power Down	17
Reset	18
Power-On Reset	18
Control.....	18
Registers	21
Host-Mode Register Access	23
Arbitrary Waveform Generation	24
Power Supply	24
JTAG Boundary Scan	24
Pin Description	32

ABSOLUTE MAXIMUM RATINGS

Parameter	Symbol	Min	Max	Units
DC Supply(TV+1,TV+2,RV+1,RV+2,AV+,DV+)(Note 1)		-	6.0	V
Input Voltage Any Pin	V _{in}	RGND-0.3	(RV+)+0.3	V
Input Current Any Pin (Note 2)	I _{in}	-10	10	mA
Ambient Operating Temperature	TA	-40	85	°C
Storage Temperature	T _{stg}	-65	150	°C

WARNING:Operations at or beyond these limits may result in permanent damage to the device.
Normal operation is not guaranteed at these extremes.

Notes: 1. Referenced to RGND1, RGND2, TGND1, TGND2, AGND, DGND at 0V.
2. Transient currents of up to 100 mA will not cause SCR latch-up.

RECOMMENDED OPERATING CONDITIONS

Parameter	Symbol	Min	Typ	Max	Units
DC Supply(TV+1,TV+2,RV+1,RV+2,AV+,DV+) (Note 3)		3.135	3.3	3.465	V
Ambient Operating Temperature	TA	-40	25	85	°C
Power Consumption (Each Channel)	T1 (Notes 4 and 5)	-	292	380	MW
	T1 (Notes 4 and 6)	-	167	220	MW
	E1, 75ohm (Notes 4 and 5)	-	180	210	MW
	E1, 120ohm (Notes 4 and 5)	-	170	200	MW
REFCLK Frequency	T1 1XCLK=1	1.544- 100ppm	1.544	1.544+ 100ppm	MHz
	T1 1XCLK=0	12.352- 100ppm	12.352	12.352+ 100ppm	MHz
	E1 1XCLK=1	2.048- 100ppm	2.048	2.048+ 100ppm	MHz
	E1 1XCLK=0	16.384- 100ppm	16.384	16.384+ 100ppm	MHz

Notes: 3. TV+1,TV+2,AV+,DV+,RV+1,RV+2 should be connected together.TGND1,TGND2,RGND1, RGND2,DGND1,DGND2,DGND3 should be connected together.
4. Power consumption while driving line load over operating temperature range. Includes IC and load. Digital input levels are within 10% of the supply rails and digital outputs are driving a 50 pF capacitive load.
5. Assumes 100% ones density and maximum line length at 3.465V.
6. Assumes 50% ones density and 300ft. line length at 3.3V.

DIGITAL CHARACTERISTICS (T_A=-40 to 85°C; power supply pins within +/-5% of nominal)

Parameter	Symbol	Min	Typ	Max	Units
High-Level input Voltage (Note 7)	V _{IH}	(DV+)-0.5	-	-	V
Low-Level input Voltage (Note 7)	V _{IL}	-	-	0.5	V
High-Level Output Voltage (Note 8) I _{OUT} =-40uA	V _{OH}	(DV+)-0.3	-	-	V
Low-Level Output Voltage (Note 8) I _{OUT} =1.6mA	V _{OL}	-	-	0.4	V
Input Leakage Current (Digital pins except INT, J_TMS, and J_TDI)		-	-	+/-10	uA

Notes: 7. Digital inputs are designed for CMOS logic levels.

8. Digital outputs are TTL compatible and drive CMOS levels into a CMOS load.

ANALOG SPECIFICATIONS (T_A=-40 to 85°C; power supply pins within +/-5% of nominal)

Parameter	Min	Typ	Max	Units	
Receiver					
Input Impedance between RTIP/RRING	-	20k	-	ohm	
Sensitivity Below DSX-1(0 dB=2.4V)	-13.6	-	-	DB	
Loss of signal threshold, Short Haul					
T1	-	0.23	-	V _{Op}	
E1	-	0.15	-	V _{Op}	
Data Decision Threshold					
T1,DSX-1 (Note 9)	60	65	70	% of Peak	
E1 (Note 10)	55	-	75		
E1 (Note 11)	45	50	55		
E1 (Note 12)	40	-	60		
Allowable Consecutive Zeros before LOS	160	175	190	bits	
Receiver Input Jitter	10 Hz and below	(Note 13)	300	-	U _{Ipp}
Tolerance(DSX-1,E1)	2 kHz		6.0	-	U _{Ipp}
	10 kHz-100 kHz		0.4	-	U _{Ipp}
Jitter Attenuator					
Jitter Attenuation Curve Corner Frequency (Note 14 and 15)					
T1	-	4	-	Hz	
E1	-	5.5	-	Hz	
Attenuation at 10 kHz Jitter frequency (Note 14 and 15)	-	60	-	dB	
Attenuator Input Jitter Tolerance (Note 14) (Before Onset of FIFO Overflow or Underflow Protection)	28	43	-	U _{Ipp}	

Notes: 9. For input amplitude of 1.2Vpk to 4.14Vpk

10. For input amplitude of 0.5Vpk to 1.2Vpk, and 4.14Vpk to 5.0Vpk

11. For input amplitude of 1.07Vpk to 4.14Vpk

12. For input amplitude of 4.14Vpk to 5.0Vpk

13. Jitter tolerance increases at lower frequencies. See Figure 11.

14. Not production tested. parameters guaranteed by design and characterization.

15. Attenuation measured with sinusoidal input jitter equal to 3/4 of measured jitter tolerance.

Circuit attenuates jitter at 20 dB/decade above the corner frequency. See Figure 16. Output jitter can increase significantly when more than 28 UI's are input to the attenuator. See discussion in jitter Attenuator section.

ANALOG SPECIFICATIONS (T_A=-40 to 85°C; power supply pins within +/-5% of nominal)

Parameter		Min	Typ	Max	Units
Transmitter					
AMI Output Pulse Amplitudes (Note 16)					
	E1,75ohm (Note 17)	2.14	2.37	2.6	V _{Op}
	E1,120ohm (Note 18)	2.7	3.0	3.3	V _{Op}
	T1,DSX-1 (Note 19)	2.4	3.0	3.6	V _{Op}
Recommended Transmitter Output Load (Note 16)					
	T1,	-	25	-	ohm
	E1,75ohm	-	43	-	ohm
	E1,120ohm	-	68.9	-	ohm
Jitter Added by the Transmitter					
	8kHz – 40kHz	-	0.013	-	UI _{pp}
	10Hz – 40kHz	-	0.016	-	UI _{pp}
	Broad Band (Note 20)	-	0.027	-	UI _{pp}
Power in 2 kHz band about 772 kHz (Notes 14 and 21) (DSX-1 only)		12.6	15	17.9	dBm
Power in 2 kHz band about 1.544 MHz (Notes 14 and 21) (referenced to power in 2 kHz band at 772 kHz) (DSX-1 only)		-29	-38	-	dB
Positive to Negative Pulse Imbalance (Notes 14 and 21)					
	T1,DSX-1	-	0.2	0.5	dB
	E1, amplitude at center of pulse interval	-5	-	+5	%
	E1, width at 50% of nominal amplitude	-5	-	+5	%
Transmitter Return Loss (Notes 14, 21, and 22)					
	51 kHz - 102 kHz	8	-	-	dB
	102 kHz - 2.048 MHz	14	-	-	dB
	2.048 MHz - 3.072 MHz	10	-	-	dB
E1 Short Circuit Current (Note 23)		-	-	50	mArms
E1 and DSX-1 Output Pulse Rise/Fall Times (Note 24)		-	25	-	ns
E1 Pulse Width (at 50% of peak amplitude)		-	244	-	ns
E1 Pulse Amplitude for a space					
	E1, 75ohm	-0.237	-	0.237	V _{Op}
	E1, 120ohm	-0.3	-	0.3	V _{Op}

Notes: 16. Using a transformer that meets the specifications in Table 2.

17. Measured across 75ohm at the output of the transmit transformer for CON2/1/0=0/0/0.

18. Measured across 120ohm at the output of the transmit transformer for CON2/1/0=0/0/1.

19. Measured at the DSX-1 Cross-Connect for line length settings CON2/1/0=0/1/0, 0/1/1, 1/0/0, 1/0/1, and 1/1/0 after the length of #22 ABAM cable specified in Table 1.

20. Input signal to TCLK is jitter free.

21. Typical performance with a 0.47 uF capacitor in series with primary of transmitter output transformer.

22. Return loss = $20 \log_{10} \text{ABS} \left(\frac{z_1+z_0}{z_1-z_0} \right)$ where z_1 = impedance of the transmitter, and Z_0 =cable impedance.

23. Transformer secondaries shorted with 0.5ohm resistor.

24. At transformer secondary. From 10% to 90% of amplitude.

SWITCHING CHARACTERISTICS-T1 CLOCK/DATA ($T_A = -40$ to 85°C ; power supply pins within $\pm 5\%$ of nominal; Inputs: Logic 0=0V, logic 1=DV+)(See Figures 1,2, and 3)

Parameter	Symbol	Min	Typ	Max	Units
TCLK Frequency (Note 25)	ftclk	-	1.544	-	MHz
TCLK Duty Cycle	tpwh2/tpw2	30	50	70	%
RCLK Duty Cycle (Note 26)	tpwh1/tpw1	45	50	55	%
Rise Time All Digital Outputs (Note 27)	tr	-	-	65	ns
Fall Time All Digital Outputs (Note 27)	tr	-	-	65	ns
TPOS/TNEG to TCLK Falling Setup Time	tsu2	25	-	-	ns
TCLK Falling to TPOS/TNEG Hold Time	th2	25	-	-	ns
RPOS/RNEG to RCLK Rising Setup Time	tsu1	-	274	-	ns
RCLK Rising to RPOS/RNEG Hold Time	th1	-	274	-	ns

Notes: 25. Max value of 8.192 MHz describes the maximum burst rate of a gapped input clock(TCLK).

For the gapped clock to be tolerated by the AK61584, the jitter attenuator must be switched to transmit path of the line interface. The maximum gap size is defined in the Analog Specification table.

26. RCLK duty cycle may be outside the spec limits when jitter attenuator is in the receive path, and when the jitter attenuator is employing the overflow/underflow protection mechanism.

27. At max load of 50pF.

SWITCHING CHARACTERISTICS-E1 CLOCK/DATA ($T_A = -40$ to 85°C ; power supply pins within $\pm 5\%$ of nominal; Inputs: Logic 0=0V, Logic 1=DV+)(See Figures 1, 2, and 3)

Parameter	Symbol	Min	Typ	Max	Units
TCLK Frequency (Note 25)	ftclk	-	2.048	-	MHz
TCLK Duty Cycle	tpwh2/tpw2	30	50	70	%
RCLK Duty Cycle (Note 26)	tpwh1/tpw1	45	50	55	%
Rise Time All Digital Outputs (Note 27)	tr	-	-	65	ns
Fall Time All Digital Outputs (Note 27)	tr	-	-	65	ns
TOPS/TNEG to TCLK Falling Setup Time	tsu2	25	-	-	ns
TCLK Falling to TOPS/TNEG Hold Time	th2	25	-	-	ns
RPOS/RNEG to RCLK Rising Setup Time	tsu1	-	194	-	ns
RCLK Rising to RPOS/RNEG Hold Time	th1	-	194	-	ns

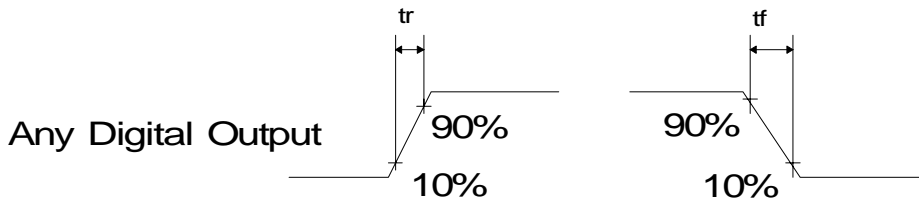

Figure 1. Signal Rise and Fall Characteristics

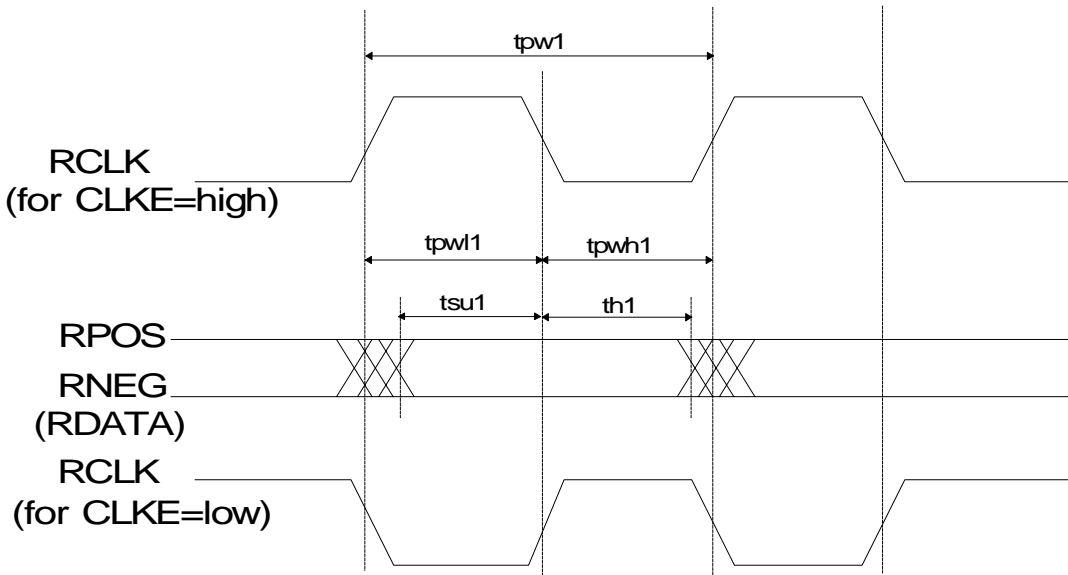

Figure 2. Recoverd Clock and Data Switching Characteristics

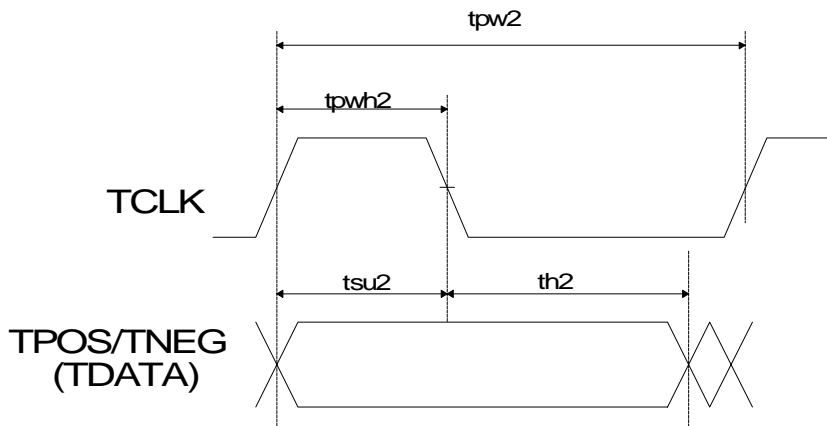

Figure 3. Transmit Clock and Data Switching Characteristics

SWITCHING CHARACTERISTICS -SERIAL PORT (TA = -40 to 85°C;
 DV+,TV+,RV+ = nominal +/-0.3V; Inputs: Logic 0 = 0V, Logic 1 = RV+)

Parameter	Symbol	Min	Typ	Max	Units
SDI to SCLK Setup Time	t _{dc}	25	-	-	ns
SCLK to SDI Hold Time	t _{cdh}	25	-	-	ns
SCLK Low Time	t _{cl}	50	-	-	ns
SCLK High Time	t _{chl}	50	-	-	ns
SCLK Rise and Fall Time	t _{r,tf}	-	-	15	ns
CS to SCLK Setup Time	t _{cc}	20	-	-	ns
SCLK to CS Hold Time (Note 28)	t _{ch}	20	-	-	ns
CS Inactive Time	t _{cih}	100	-	-	ns
SCLK to SDO Valid (Note 29)	t _{cdv}	-	-	50	ns
CS to SDO High Z	t _{cdz}	-	50	-	ns

Notes: 28. If SPOL=0, then CS should return high no sooner than 20ns after the 16th falling edge of SCLK during a serial port read.
 29. Output load capacitance = 50 pF.

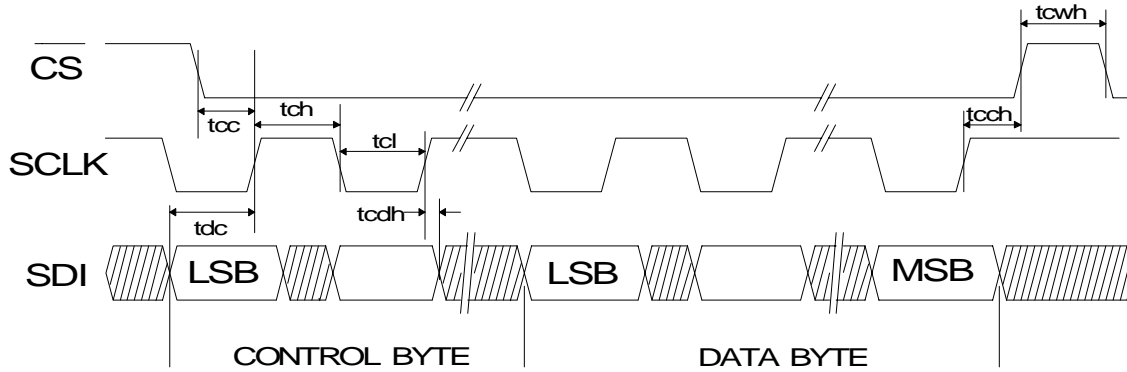

Figure 4. Serial Port Write Timing Diagram

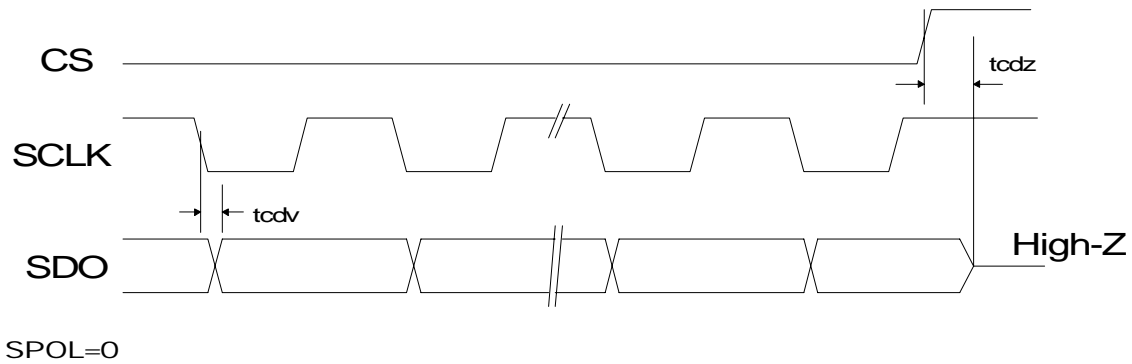

Figure 5. Serial Port Read Timing Diagram

SWITCHING CHARACTERISTICS -JTAG ($T_A = -40$ to 85°C ;
 $TV+,RV+ = \text{nominal } \pm 0.3\text{V}$; Inputs: Logic 0 = 0V, Logic 1 =RV+)

Parameter	Symbol	Min	Typ	Max	Units
Cycle Time	t_{cyc}	200	-	-	ns
J_TMS/J_TDI to J_TCK rising setup time	t_{su}	50	-	-	ns
J_CLK rising to J_TMS/J_TDI hold time	t_h	50	-	-	ns
J_TCLK falling to J_TDO valid	t_{dv}	-	-	50	ns

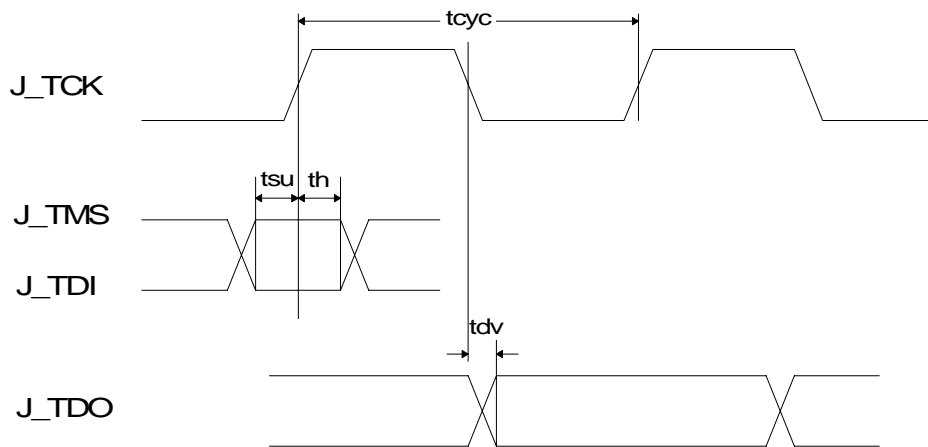

Figure 6. JTAG Switching Characteristics

OVERVIEW

The AK61584 is a universal line interface for T1/E1 applications, designed for high-volume cards where low power, high density and universal operation is required. One board design can support all T1/E1 short-haul modes. The T1 and E1 modes can be selected entirely via software.

As shown in Figure 1, the AK61584 provides all the functions needed for a line interface including a line driver, a receiver and jitter attenuator.

The line driver generates waveforms compatible with E1 (ITU-T G.703), T1 short haul (DSX-1).

The driver internally matches the impedance of the load, providing excellent return loss. The benefit of the internal impedance matching is a 50 percent reduction in power consumption compared to implementing return loss with external resistors. With external resistors a driver has to drive the equivalent of two line loads.

The receiver contains clock and data recovery circuits.

The jitter attenuator meets AT&T 62411 requirements without the use of an external quartz crystal. The attenuator does require an external reference clock.

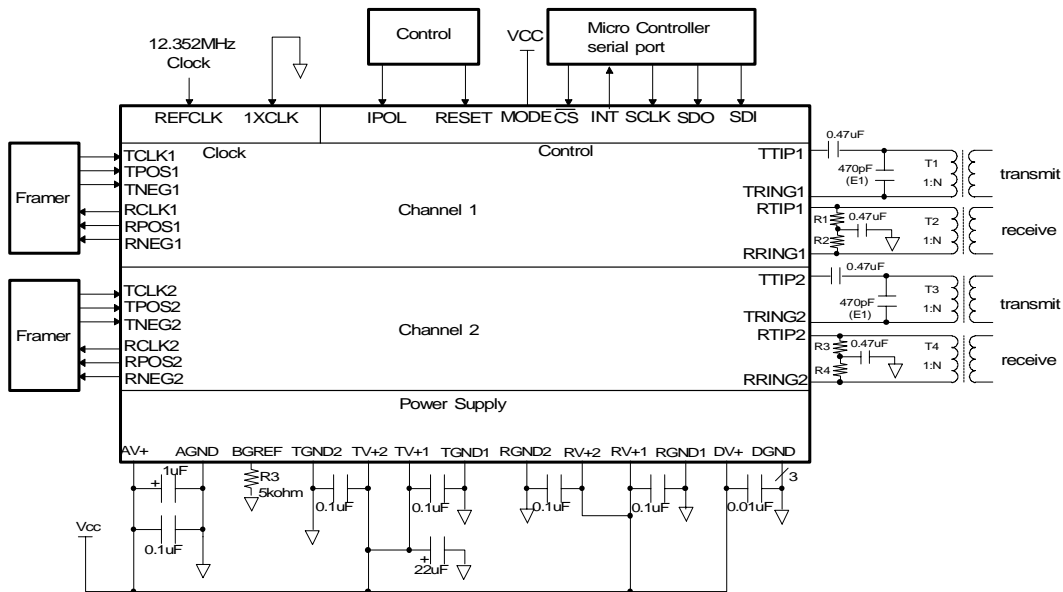

Vcc Volts	Data Rate MHz	REFCLK Frequency MHz		Cable ohm	R1-R4 ohm	Transformers T1-T4
		1XCLK=1	1XCLK=0			
3.3	1.544	1.544	12.352	100	12.5	1:2
	2.048	2.048	16.384	75	21.5	1:1.32
				120	34.4	

Figure 7 - Typical Connection Diagram
(Host Mode)

OPERATING OPTIONS

The following are the major operating options which are supported by the AK61584:

Control

Control of the AK61584 is via either *host mode* (serial port) or *hardware mode* (individual control lines). Hardware mode offers significantly fewer programmability options than the host mode.

T1/E1

The AK61584 supports T1 short-haul (DSX-1), and E1 operation. The configuration pins (CON <0:2>) and register bits control transmitted pulse shapes, transmitter source impedance, and receiver slicing level. Both channels must be operated at the same rate (both T1 or both E1).

The pulse shapes are fully pre-defined by circuitry in the AK61584, and are fully compliant with appropriate standards when used with our application guidelines in standard installations.

The transmitter impedance changes with the line length options in order to match the impedance of the load (75-ohm for E1 coax, 100-ohm for T1, 120-ohm for E1 Shielded twisted pair).

The receiver slicing level is set at 65% for DSX-1 short-haul, and at 50% for all other applications.

Line Codes

The AK61584 supports a *transparent mode* where the line code is encoded and decoded by an external

T1/E1 framing device. Alternatively, a *coder mode* can be selected. In coder mode, an internal B8ZS/AMI/HDB3 coder can be used on those systems which don't need T1/E1 framers (typically high-speed multiplexers). In host mode, the choice of transmit encoder is independent of the choice of receiver decoder.

Reference Clock

The AK61584 requires a T1 or E1 reference clock. This clock can be either a 1-X clock (i.e., 1.544 MHz or 2.048MHz), or can be a 8-X clock (i.e., 12.352 MHz or 16.384 MHz). In systems which want software selection of data rate, the 1-X clock option is typically chosen, and the reference clock is tied to the transmit clock. In systems with a jittered transmit clock, an external oscillator should drive the reference clock input, and a 8-X rate can be used to minimize the physical size of the oscillator. In either case, any jitter present on the reference clock will not be filtered by the jitter attenuator, and the reference clock should have 100 ppm or better frequency accuracy.

Power Down

Either one of the two line interfaces may be independently powered down.

Jitter Attenuator

The jitter attenuator may be placed in the receiver path, the transmit path or bypassed entirely.

OVERVIEW OF APPLICATIONS

This section summarizes a typical application of the AK61584 in various environments, and discusses what AK61584 options would normally be selected in that application. See Figure 8.

AT&T 62411 Customer Premises Application

AT&T 62411 applies at the T1 interface between the customer premises and the carrier, and must be implemented by the customer premises equipment.

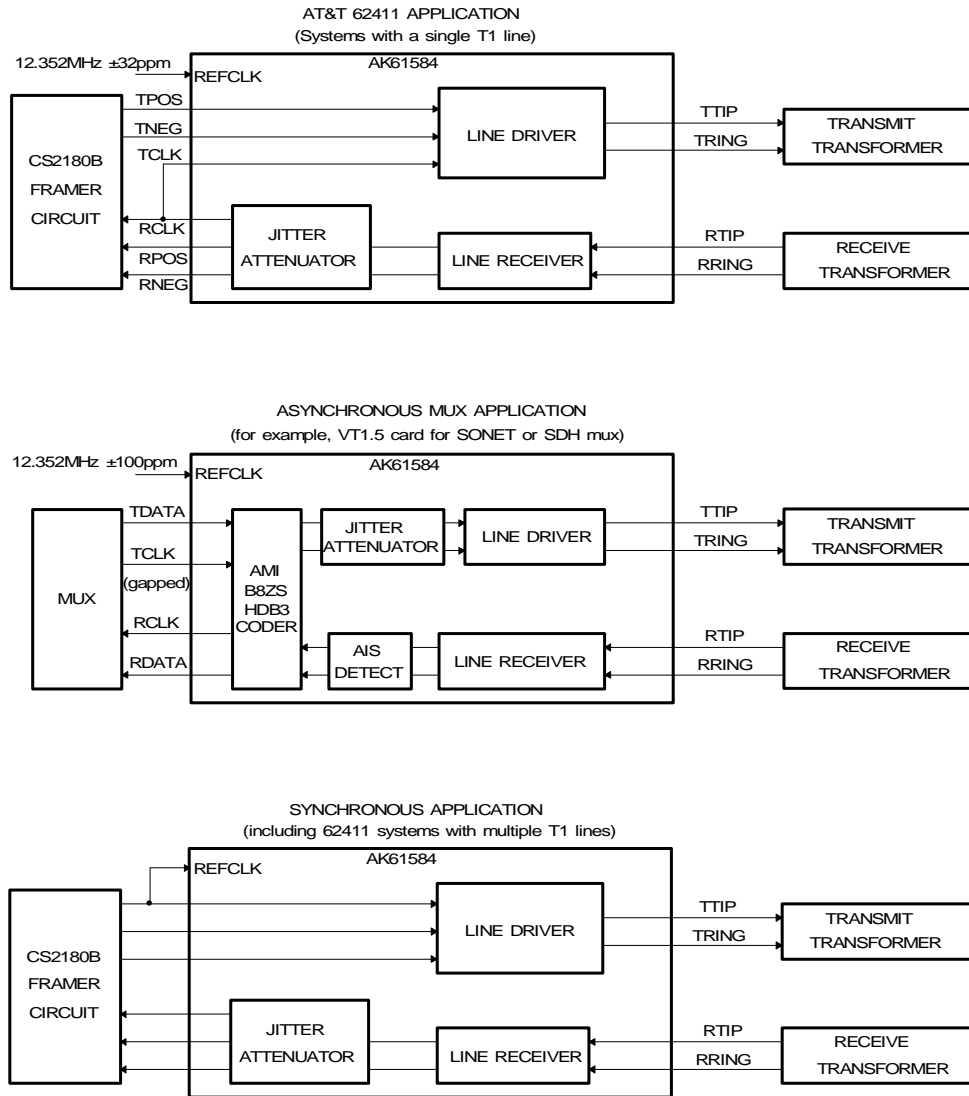

Figure 8. Configuration Examples for Various Applications

In 62411 applications, an overriding design consideration is management of jitter. Typically, the AK61584 will use its jitter attenuator on the receive side to reduce the jitter seen by the system synchronizer. The transmit clock presented to the AK61584 by the system will be Stratum 4 quality or better, and is input to both the reference clock pin and transmit clock pin. If an independent clock source is used for the reference clock, the jitter on the reference clock must be well below the jitter allowed by 62411.

Category I Asynchronous Multiplexer Application

Asynchronous multiplexers take multiple T1/E1 lines (which are asynchronous to each other), and combine them into a higher speed transmission rate. Examples are M13 muxes, and SONET muxes. In these systems, the jitter attenuator is used on the transmit side of the AK61584 to remove the waiting time jitter caused by the multiplexer. Because the transmit clock is jittered, the reference clock to the AK61584 will be provided by an external quartz crystal, which operates at the 1-X or 8-X data rate. T1/E1 framers are typically not required in asynchronous multiplexers, so the B8ZS/AMI/HDB3 coders in the AK61584 are activated.

Category II Synchronous Application

A typical example of a category II application is a T1 card of a central office switch or a 0/1 digital cross-connect system. These systems use receive side jitter attenuation to reduce the jitter presented to the system, and will use a Stratum 3 or better system clock to feed the AK61584 transmit and reference clocks. In these systems, a single hardware design can support T1 and/or E1 under software control since the rate of the transmit/reference clock rate will be varied by the system to match the line rate(T1 or E1).

TRANSMITTER

The transmitter takes data from a T1 or E1 terminal, and produces pulses of appropriate shape. The transmit clock (TCLK) and transmit data (TPOS & TNEG, or TDATA) are supplied synchronously. Data is sampled on the falling edge of the input clock.

Pulse shaping and signal level are determined by configuration inputs as shown in Table 1. Typical output pulses are shown in Figures 9 and 10.

C O N 2	C O N 1	C O N 0	TRANSMITTER Pulse Width at 50% amplitude	Pulse Shape	RECEIVER Slicing Level	Coder
0	0	0	244 ns(50%)	E1:square, 2.37 Volts into 75ohm	50%	AMI/HDB3
0	0	1	244 ns(50%)	E1:square, 3.00 Volts into 120ohm	50%	AMI/HDB3
0	1	0	350 ns(54%)	DSX-1:0-133ft	65%	AMI/B8ZS
0	1	1	350 ns(54%)	DSX-1:133-266ft	65%	AMI/B8ZS
1	0	0	350 ns(54%)	DSX-1:266-399ft	65%	AMI/B8ZS
1	0	1	350 ns(54%)	DSX-1:399-533ft	65%	AMI/B8ZS
1	1	0	350 ns(54%)	DSX-1:533-655ft	65%	AMI/B8ZS

CON3 must be set to 0.

Table 1. Configuration Selection

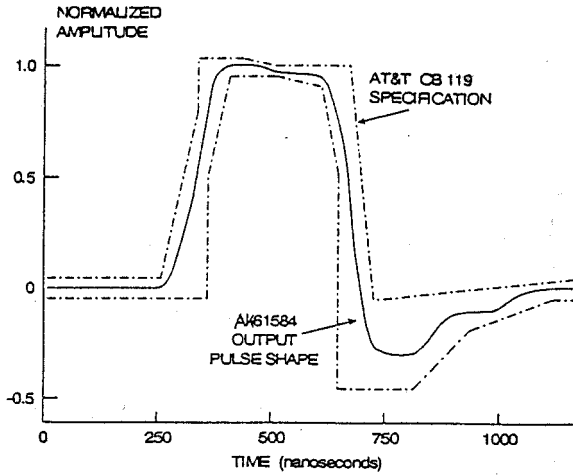

Figure 9. Typical Pulse Shape at DSX-1 Cross Connect

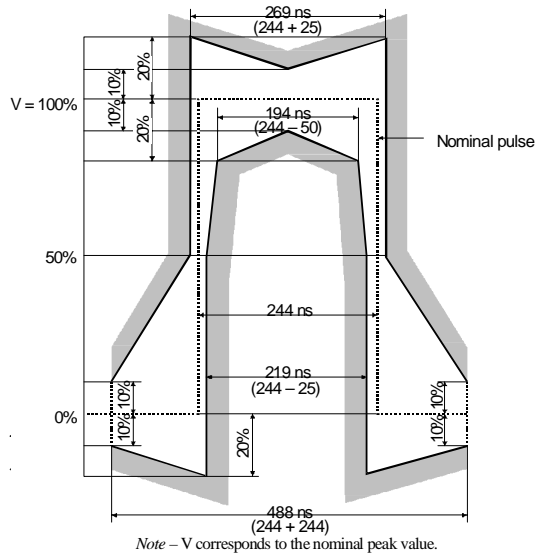

Figure 10. Mask of the Pulse at 2048kbps Interface

The line driver internally matches the impedance of the line load, providing 14 dB of return loss during the transmission of both marks and spaces. This improves signal quality by minimizing reflections off the transmitter. Internal impedance matching reduces current consumption by factor of nearly two compared to return loss achieved by external resistors.

The transmitter provides for all ones insertion at the frequency of REFCLK. Transmit all ones is selected when TAOS goes high, and causes continuous ones to be transmitted on the line (TTIP and TRING). In this mode, the TPOS and TNEG, or TDATA, inputs are ignored.

When any transmit control pin (TAOS, LLOOP, or CON<0-2>) is toggled, the transmitter stabilizes within 22 bit periods. The transmitter will take longer to stabilize when RLOOP is selected because the timing circuitry must adjust to the new frequency.

Recommended transmitter transformer specifications are shown below:

When the transmitter transformer secondaries are shorted via a 0.5ohm resistor, the transmitter will out-

put a maximum of 50 mA-rms, as required by the British OFTEL OTR-0001 specification.

Turns ratio	1:2 step-up for TX(T1) 1:2 step-down for RX(T1) 1:1.32 step-up for TX(E1) 1:1.32 step-down for RX(E1)
Primary inductance	1.5 mH min measured at 772 kHz
Primary leakage Inductance	0.3 uH max at 772 kHz with secondary shorted
Secondary leakage Inductance	0.4 uH max at 772 kHz
Interwinding Capacitance	18 pF max, primary to secondary
ET-constant	16 V-us min

Table 2(a). Transformer Requirements

Turns Ratio	Part#	Manufacturer
1:2(T1)	PE-65351 4023	Pulse Engineering JPC Corporation
1:1.32(E1)	67148170 4022	Schott Corporation JPC Corporation

Table 2(b) Recommended Transformer

RECEIVER

The receiver extracts data and clock from the T1/E1 signal and outputs clock and synchronized data. The receiver can receive signals over the entire range of short haul cable lengths.

The clock recovery circuit is a second-order phase lock loop, and can tolerate as much as 0.4UI of jitter from 10 kHz to 100kHz, without error (Figure 11). The clock and data recovery circuit is tolerant of long strings of consecutive zeros, and will successfully receive a 1-in-175, jitter-free input signal.

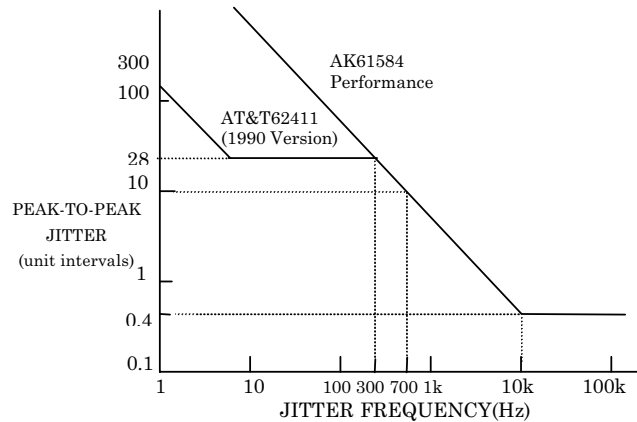

Figure 11. Minimum Input Jitter Tolerance of Receiver (Clock Recovery Circuit and Jitter Attenuator)

Data at RPOS and RNEG, is stable and may be sampled using the recovered clock. CLKE determines the clock polarity for which output data is stable and valid as shown in Table 3. When CLKE is high, RPOS and RNEG are valid on the falling edge of RCLK. When CLKE is low, RPOS and RNEG are valid on the rising edge of RCLK. In Hardware mode, the CLKE selection is made via pin 27. In host mode, the CLKE selection

is mode via control register (Channel 1 Control A, bit 7).

CLKE	DATA	CLOCK	Clock edge for valid data
LOW	RPOS	RCLK	Rising
	RNEG	RCLK	Rising
HIGH	RPOS	RCLK	Falling
	RNEG	RCLK	Falling

Table 3. Data Output/Data relationship

The signal is detected differentially across the receive transformer. Recommended receiver transformer specifications are identical to the transmit transformer specifications.

Receiver Loss of Signal

The receiver will indicate loss of signal upon receiving 175+/-15 consecutive zeros. A digital counter counts received zeros, based on recovered clock cycles. The receiver reports loss of signal by setting the appropriate Loss of Signal pin, LOS high. The LOS condition is exited using the ANSI T1.231- 1993 criteria, namely 12.5% ones density for 175+/-75 bit periods with no more than 100 zeros in a row.

If a loss of signal condition occurs when the host mode is being used, the LOS and LOS-latched bits will be set and an interrupt will be issued. LOS will go low (and flag the interrupt pin again, if the serial I/O is used) when a valid signal is detected. The LOS-latched bit will stay high until read, and then will remain low until the next loss of signal event occurs. See Figure 12. Note that in the hosts mode serial port operation, LOS is simultaneously available from both the register and pin LOSx.

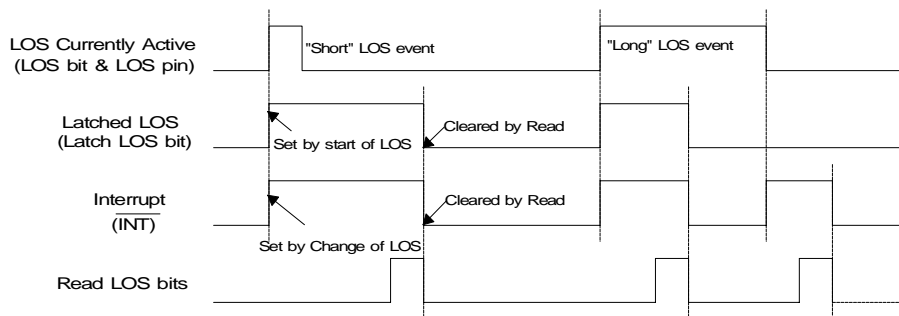

Figure 12 Loss of Signal Event Relationship

When the jitter attenuator is in the receive path, upon loss of signal, the frequency of last recovered signal is held over. When the jitter attenuator is not in the receive path, the last recovered frequency is not held over. Rather, the output frequency will become the frequency of the reference clock.

Any time a channel is reset or powered down, (for example by RESET, PD1, PD2, or power-on reset), the loss of signal indicator on that channel is set high. The loss of signal indicator remains high until data is recovered by the receiver.

Receiver AIS Detection

The receiver detects AIS upon observation of 99.9% ones density for 5.3 ms. More specifically, the AIS detection criteria is less than 9 zeros out of 8192 bits. When AIS is detected, the AK61584 sets the control register bits AIS and Latched-AIS, high. In the coder mode, the receiver also sets output pin AIS high. The end of the AIS condition occurs when ≥ 9 zeros are detected out of 8192 bits. The AIS bits in the status register operate the same as the LOS bits (see Table5) upon detecting AIS. When a channel is powered down, all indications are forced low.

JITTER ATTENUATOR

The jitter attenuator can be switched into either the receive or transmit paths. Alternatively it can be removed from both paths (thereby decreasing propagation delay).

Atten0x	Atten1x	Location of Jitter Attenuator
0	0	Receiver
0	1	Transmitter
1	0	Neither
1	1	Reserved

Table 4. Jitter Attenuation Control

In hardware mode, the location of the attenuators is the same for channel 1 and 2, and is controlled by pins ATTEN0 and ATTEN1. See Table4. In host modes,

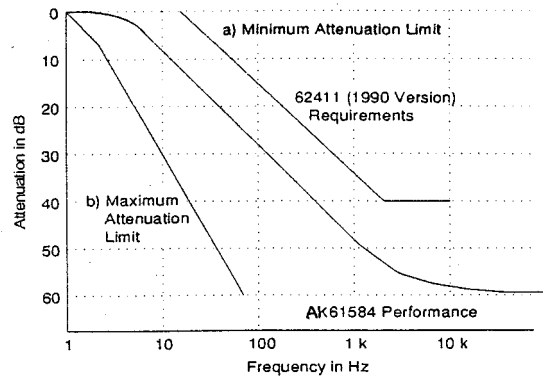

Figure 13. Typical Jitter Transfer Function

the location of the attenuators is programmable on a per-channel basis, using bits ATTEN01 and ATTEN11 for channel 1, and bits ATTEN02 and ATTEN12 for channel 2. The control bits also conform to Table 4.

A typical jitter attenuation curve is shown in Figure 13.

The attenuator consists of a 64-bit FIFO, a narrow-band monolithic PLL, and control logic. Signal jitter is absorbed in the FIFO. The FIFO is designed to neither overflow nor underflow. If overflow or underflow is imminent, the jitter transfer function is altered to insure that no bit errors occur. Under this circumstance, jitter gain may occur, and jitter should be attenuated externally in a frame buffer. The jitter attenuator will typically tolerate 43 UIs before the overflow/underflow mechanism takes effect. Before the jitter attenuator has had time to “lock” to the average incoming frequency, for example, after a chip reset, the attenuator will tolerate a minimum of 22 UIs before the overflow/underflow mechanism takes effect.

For T1/E1 line cards employed in high-speed multiplexers (e.g.,SONET and SDH), the jitter attenuator is typically used in the transmit path. The attenuator can be fed a gapped transmit clock, with gaps 22 UIs, and transmit clock burst rate ≤ 8 MHz.

CODER MODE

In the coder Mode, three line codes are available: AMI, B8ZS and HDB3. The input to the encoder is TDATA. The outputs from the decoder are RDATA and BPV (Bipolar Violation Strobe). In host modes, the encoder and decoder are selected using control register bits CODER (1 =coder active, 0 = transparent mode, coder disabled) and AMI-T/AMI-R (1 =AMI, 0 =B8ZS or HDB3) where the transmitter and receiver can be independently controlled. The selection of B8ZS versus HDB3 is made by the control bits: CON<0:3>. In hardware mode, the encoder and decoder are controlled simultaneously by pins CODER1 and CODER2 (1 =coder active, 0 =transparent mode, coder disable). The line code is B8ZS or HDB3. The selection of B8ZS versus HDB3 is made by the pins: CON<0:2>.

In the coder mode, the receiver sets output pins AIS1 and AIS2 high, when AIS is detected, respectively on channels 1 and 2.

In the coder mode, pin BPV goes to a logic 1 for one bit period when a bipolar violation is detected in the received signal. B8ZS (or HDB3) zero substitutions are not flagged as bipolar violations if the B8ZS (or HDB3) decoder has been enabled. A latched-BPV indication is also available in the status register.

REFERENCE CLOCK

The AK61584 requires a T1 or E1 reference clock. This clock is input on pin REFCLK, and can be either a 1-X clock (i.e.,1.544 MHz or 2.048 MHz), or a 8-X clock (i.e.,12.352 MHz or 16.384 MHz). pin 1XCLK determines which option is used (active high for 1-X, and low for 8-X).

Any jitter present on the reference clock will not be filtered by the jitter attenuator, and will be present on the output of the jitter attenuator. The reference clock should have a minimum accuracy of 100 ppm.

LOOPBACKS

Local Loopbacks

The two local loopbacks take clock and data presented on TCLK, TPOS, and TNEG, or TDATA and outputs it at RCLK, RPOS and RNEG, or RDATA. As shown in the block diagram on the first page of the data sheet, loopback 1 includes the jitter attenuator. Loopback 2 includes the line driver and the receiver.

For both local loopbacks, inputs to the transmitter are still transmitted on the line, unless TAOS has been selected in which case, AMI-coded continuous ones are transmitted to the line at the rate determined by TCLK. Receiver inputs are ignored when local loopback is in effect. Local loopback 1 is selected by a control pin, or a control bit. Loopback 2 is selected only via a control bit.

Remote Loopback

In remote loopback, the recovered clock and data input on RTIP and RRING are sent back out on the line via TTIP and TRING as shown in the block diagram on the front page of this data sheet. The recovered incoming signals are also sent to RCLK, RPOS and RNEG, or RDATA. A remote loopback may be selected in both the hardware and host modes. Simultaneous selection of local and remote loopback modes is not valid.

POWER DOWN

The PD1 and PD2 pins reset, respectively, the transmitter, receiver and jitter attenuator of channels 1 and 2. Whenever PD1 or PD2 is selected, the selected channel remains powered down, and the outputs (pins RCLK, RPOS, RNEG, RDATA, BPV, AIS, TTIP, and TRING) associated with that channel are put into a high-impedance state, and pin LOS is set high. Additionally, the status register bits are reset. The control, mask, and arbitrary waveform registers are unchanged.

The non-selected channel operates normally. Selecting PD1 or PD2 does not reset the AK61584 control registers, or serial control ports. Simultaneously selecting PD1 and PD2 will power down some additional analog circuitry that is shared by both channels. After exiting the power down state, the channel will be fully operational in less than 20 ms.

RESET

In operation, the AK61584 is continuously calibrated, making the performance of the device independent of power supply or temperature variations. The continuous calibration function forgoes any requirement to reset the line interface when in operation.

The RESET pin resets the entire device, including the control logic, and clears all control and mask registers. A reset event results in the Latched-reset bit being set in the Status register. A reset request can be made by setting RESET high for at least 200 ns. Reset will initiate on the falling edge of RESET. The reset operation takes less than 20 ms to complete. Upon exiting RESET, both channels are powered up.

POWER ON RESET

Upon power-up, the IC is held in a static state until the supply crosses a threshold of approximately 60% of the power supply voltage. When this threshold is crossed, the device will delay for about 10 ms to allow the power supply to reach operating voltage. After this delay, calibration of the transmit and receive sections commences. The calibration can take place only if REFCLK and TCLK are present. The initial calibration takes less than 20 ms. The power-on reset has the same effect as the RESET. A power-on reset event results in the Latched-reset bit being set in the Status register.

CONTROL

Control of the AK61584 is via either host mode (register read/write via serial control port), or hardware mode (individual control pin). Hardware mode offers significantly fewer programmability options than the host mode.

The following pins are used to select the mode. The MODE pin active low selects Hardware mode. The MODE pin active high enables host mode. Once host mode is invoked, the pin 16 must be set to logic low. The definition of the pins in each mode is shown in the block diagram of the first page of the data sheet.

Hardware Mode

The following control options are available in Hardware mode on a per channel basis: power down, remote loopback, transmit all ones, coder mode, line length selection and location of jitter attenuator.

Host Modes

Host mode allows a microcontroller to read/write ten AK61584 control and status registers. The registers are defined in Table 5, and discussed in a later section. Host mode interface ports are available for serial.

In host mode, the AK61584 registers occupies a six-bit address space, where those six bits select a register in the range h10 to h19.

The AK61584 generates an interrupt on pin INT whenever a status register changes. The polarity of the INT pin is programmable. When the IPOL pin is high, INT goes high to generate a processor interrupt. When the IPOL pin is low, INT goes low to generate a processor interrupt.

REGISTERS

The control and status registers are defined in Table 5, and are accessible in host mode. Each channel has its own set of Status, Mask and Control. The status register is read-only. Writing to the status register has no impact on its contents. Interrupts are generated on the INT pin every time a status register changes. Reading a status register resets all bits in that status register to 0. The mask register allows the user to mask interrupts on a status register on a per-bit basis. The control registers select features /functionality.

Status Registers Description

Each bit in the status register is defined below.

AIS and Latched-AIS: Indicates an all-ones condition. AIS is set high while AIS condition is currently detected. Latched-AIS indicates that a AIS condition has occurred since the last read of the status register.
 Interrupt: Indicates that the status register has changed

sometime since the last read of the status register.

Latched-BPV: indicates a bipolar violation event has been detected in the receiver sometime since the last read of the status register. This bit is set only when the line-code decoder is enabled.

Latched-Overflow: Indicates that a waveform generated using the Arbitrary Waveforms has exceeded full scale sometime since the last read of the status register. (Optional information, refer to the Application Note.)

LOS and Latched-LOS : Indicates loss of signal condition. LOS is set high while LOS condition is currently detected. Latched-LOS indicates that a LOS condition has occurred since the last read of the status register.

Latched-reset: Indicates that a reset event (power-up or manual) has occurred since the last read of the status register. This status bit is not maskable.

Register Address	Bit	Name	Definition		Reset Value
			1	0	
h10 Channel 1 Status					
b0000					
	7	LOS1	LOS currently detected	no LOS	1
	6	Latched-LOS1	LOS event since last read	no LOS	1
	5	AIS1	AIS currently detected	no AIS	0
	4	Latched-AIS1	AIS event since last read	no AIS	0
	3	Latched-BPV1	BPV event since last read	no BPV	0
	2	Latched -Overflow1	Pulse overflow since last Read	no overflow	0
	1	Latched-reset	Reset event since last read	no reset	1
	0	Interrupt1	Interrupt event since last Read	no interrupt	0
h11 Channel 2 Status					
b0001					
	7	LOS2	LOS currently detected	no LOS	1
	6	Latched-LOS2	LOS event since last read	no LOS	1
	5	AIS2	AIS currently detected	no AIS	0
	4	Latched-AIS2	AIS event since last read	no AIS	0
	3	Latched-BPV2	BPV event since last read	no BPV	0
	2	Latched -Overflow2	Pulse overflow since last Read	no overflow	0
	1	reserved			0
	0	Interrupt2	Interrupt event since last Read	no interrupt	0

Table 5(a). Status Registers

Register Address	Bit	Name	Definition		Reset Value
			1	0	
h10 Channel 1 Mask					
b0010					
	7	Mask LOS1	Mask status bit 7	Enable status bit 7	0
	6	Mask Latched-LOS1	Mask status bit 6	Enable status bit 6	0
	5	Mask AIS1	Mask status bit 5	Enable status bit 5	0
	4	Mask Latched-AIS1	Mask status bit 4	Enable status bit 4	0
	3	Mask Latched-BPV1	Mask status bit 3	Enable status bit 3	0
	2	Mask Latched-Overflow1	Mask status bit 2	Enable status bit 2	0
	1	reserved			0
	0	Mask Interrupt1	Mask status bit 0 & Interrupt pin	Enable status bit 0 & Interrupt pin	0
h11 Channel 2 Mask					
b0011					
	7	Mask LOS2	Mask status bit 7	Enable status bit 7	0
	6	Mask Latched-LOS2	Mask status bit 6	Enable status bit 6	0
	5	Mask AIS2	Mask status bit 5	Enable status bit 5	0
	4	Mask Latched-AIS2	Mask status bit 4	Enable status bit 4	0
	3	Mask Latched-BPV2	Mask status bit 3	Enable status bit 3	0
	2	Mask Latched-Overflow2	Mask status bit 2	Enable status bit 2	0
	1	reserved			0
	0	Mask Interrupt2	Mask status bit 0 & Interrupt pin	Enable status bit 0 & Interrupt pin	0

Note)Mask LOS and Mask Latched-LOS need to controlled simultaneously, and Mask AIS and Mask Latched-AIS also.

Table 5(b). Mask Registers

Mask Registers Description

Writing a “1” to a bit of the mask register forces the corresponding bit of the status register to stay fixed at “0”.

Control A Registers Description

Each bit in the control register is defined below.

AMI-R: Writing a “0” enables the B8ZS or HDB3 decoder in the receiver path. B8ZS vs. HDB3 selection is determined by the CON<0:2> bits. Writing a “1” enables the AMI decoder.

AMI-T: Writing a “0” enables the B8ZS or HDB3 encoder in the transmit path. B8ZS vs. HDB3 selection is determined by the CON<0:2> bits. Writing a “1” enables the AMI encoder.

CLKE: When CLKE is set to “1”. RPOS and RNEG are valid on the falling edge of RCLK. When CLKE is set to “0”, RPOS and RNEG are valid on the rising edge of RCLK. This bit controls the RPOS/RNEG polarity for both host modes. The CLKE pin provides the same functionality for the hardware mode.

Register Address	bit	Name	Definition		Reset Value
			1	0	
h14 Channel 1 Control A					
b0100					
	7	CLKE	RPOS/RNEG valid on Falling RCLK	RPOS/RNEG valid on rising RCLK	0
	6	PD1	Power Down Channel 1	Power Up Channel 1	0
	5	ATTEN01	ATTEN01 ATTEN11		0
	4	ATTEN11	0 0	Attenuator 1 in receiver path	0
			0 1	Attenuator 1 in transmit path	
			1 0	Attenuator 1 inactive	
	3	CODER1	Coder/Mode enabled	Transparent mode enabled	0
	2	AMI-T1	AMI encoder enabled	B8ZS/HDB3 encoder enabled	0
	1	AMI-R1	AMI decoder enabled	B8ZS/HDB3 decoder enabled	0
	0	Factory Test 1	Test	Normal Operation	0
h15 Channel 2 Control A					
b0101					
	7	Reserved	Must be set to 0		0
	6	PD2	Power Down Channel 2	Power Up Channel 2	0
	5	ATTEN02	ATTEN02 ATTEN12		0
	4	ATTEN12	0 0	Attenuator 2 in receiver path	0
			0 1	Attenuator 2 in transmit path	
			1 0	Attenuator 2 inactive	
	3	CODER2	Coder/Mode enabled	Transparent mode enabled	0
	2	AMI-T2	AMI encoder enabled	B8ZS/HDB3 encoder enabled	0
	1	AMI-R2	AMI decoder enabled	B8ZS/HDB3 decoder enabled	0
	0	Factory Test	Test	Normal Operation	0

Table 5(c). Control A Registers

CODER: Writing a “1” enables a coder (AMI, B8ZS or HDB3), and enables pins TDATA, RDATA, AIS and BPV. Writing a “0” disables the coder, placing the channel in transparent mode, and enables pins TPOS, TNEG, RPOS and RNEG.

Factory Test: Must be set to “0” for normal operation.

PD: Writing a “1” powers down the channel.

Control B Registers Description

Each bit in the control register is defined below.

CON<0:2>: controls the configuration of the transmitter, receiver and coder as shown in Table 1. Both channels must operate at the same rate (both T1 or both E1). Specifications are not guaranteed with the

channels operating at different rates. After a manual or power-on reset, the CON bits are reset to the E1 rate. If a single channel T1 mode is desired (i.e., second channel is not used), it is recommended that both channels be set to the T1 rate.

LLOOP1: Writing a “1” enables local loopback #1, as shown in the block diagram on the front page of the data sheet.

LLOOP2: Writing a “1” enables local loopback #2, as shown in the block diagram on the front page of the data sheet.

RLOOP: Writing a “1” enables remote loopback for this channel.

TAOS: Writing a “1” enables transmit all ones.

Register Address	Bit	Name	Definition		Reset Value
			1	0	
h16 Channel 1 Control B					
b0110					
	7	TAOS1	Enable transmit all ones	disable transmit all ones	0
	6	RLOOP1	Enable remote loopback	disable remote loopback	0
	5	LLOOP11	Enable local loopback #1	disable loopback #1	0
	4	LLOOP21	Enable local loopback #2	disable loopback #2	0
	3	CON31	Must be set to 0		0
	2	CON21	See Table 1		0
	1	CON11	See Table 1		0
	0	CON01	See Table 1		0
h17 Channel 2 Control B					
b0111					
	7	TAOS2	Enable transmit all ones	disable transmit all ones	0
	6	RLOOP2	Enable remote loopback	disable remote loopback	0
	5	LLOOP12	Enable local loopback #1	disable loopback #1	0
	4	LLOOP22	Enable local loopback #2	disable loopback #2	0
	3	CON32	Must be set to 0		0
	2	CON22	See Table 1		0
	1	CON12	See Table 1		0
	0	CON02	See Table 1		0

Table 5(d). Control B Registers

Note) CON3 is used for Arbitrary Waveform Generation. Please connect to 0 for the normal operation.

Register Address	Bit	Name	Definition	Reset Value
h18 Channel 1 Arbitrary Pulse Shape				
b1000				
	7	MSB		Undefined
	6			Undefined
	5			Undefined
	4			Undefined
	3			Undefined
	2			Undefined
	1			Undefined
	0			LSB
h19 Channel 2 Arbitrary Pulse Shape				
b1001				
	7	MSB		Undefined
	6			Undefined
	5			Undefined
	4			Undefined
	3			Undefined
	2			Undefined
	1			Undefined
	0			LSB

Table 5(e). Arbitrary Waveform Registers

7 (MSB)	6	5	4	3	2	1	0 (LSB)
BM	ADD5	ADD4	ADD3	ADD2	ADD1	ADD0	R/W
0 individual	(MSB) Don't care		Register Address Field (LSB)				0 Write
1 Burst							1 Read

Figure 14. Address Command Byte (ACB)

HOST MODE REGISTER ACCESS

This mode is selected by setting pin MODE to logic high, and pin 16 must be set to logic low. In the host mode, the on-board registers can be written to via the SDI pin or read from via the SDO pin at the clock rate determined by SCLK. Through these registers, a host controller can be used to control operational characteristics and monitor device status. The serial port read/write timing is independent of the system transmit and receive timing.

Any read or write to the serial port is initiated by setting Chip Select (CS) low and writing an 8-bit address/command byte (ACB). The ACB consists of the three separate fields including a 6-bit register address (see Figure 14). The ACB is followed by a data word.

In the ACB, D0(LSB) is the $\overline{R/W}$ field, and specifies whether the current operation is to be a read or a write: 1 = read, 0= write. The next 4 bits (D1-D4) contain the address field. They specify which of the registers to access. D5 and D6 are “don’t care bits”. Setting bit D7 to 1 selects burst mode (described below).

Registers h10 to h17 are read and written as described above. Registers h18 and h19 are used to access multiple bytes for the arbitrary waveform generation, refer to the AK61584 Application Note.

Another communication option, burst mode, is available. Burst mode is specified by setting bit D7(MSB) of the ACB to 1. Burst mode allows multiple registers to be consecutively read or written. Writing all registers allows fast initialization at power-up or system reset. When using burst mode, the address field of the ACB command word must be h00. The registers are read or written in address order h10 to h11, followed by 42 byte reads or writes to register h18, followed by 42 bytes read or writes to register h19. Burst mode ends on the first rising edge of CS, and may be ended at any time. If a burst write ends before writing 92 bytes, the remaining, unwritten bytes are unchanged.

Figure 15 shows the timing relationships for data transfers. When the SPOL pin is high, data on SDO is valid on the falling edge of SCLK. When the SPOL pin is low, data on SDO is valid on the rising edge of SCLK.

All data is written to and read from the port LSB first. When writing to the port, SDI input data is sampled on the rising edge of SCLK.

SDO goes to high impedance state when not in use. SDO and SDI may be tied together in applications where the host processor has a bi-directional I/O port.

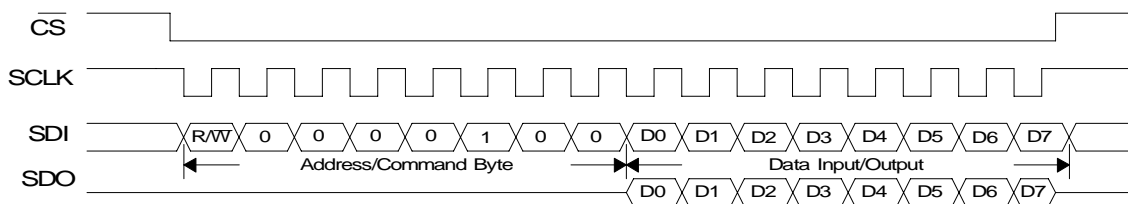

Figure 15. Serial Read/Write Timing

Arbitrary Waveform Registers

These registers are written multiple times to enter an arbitrary waveform.

ARBITRARY WAVEFORM GENERATION

In addition to the predefined pulse shapes, the user can create arbitrary pulse shapes using the host mode for evaluation. Refer to the AK61584 Application Note.

POWER SUPPLY

The device operates from a single 3.3 Volt supply. Separate pins for the various supplies provide internal isolation. However, these pins should be connected externally with the power supply pins de-coupled to their respective grounds. The various ground pins must not be more negative than AGND.

De-coupling and filtering of the power supplies is crucial for the proper operation of the analog circuits. The best way to configure the power supplies is to tie all of the supply pins together at the chip. As shown in Figure 1, a capacitor should be connected between each supply and its respective ground. For the 1uF and smaller capacitors, use mylar or ceramic capacitors and place them as closely as possible to their respective power supply pins. Wire-wrap bread boarding of the line interface is not recommended because lead resistance and inductance serve to defeat the func-

tion of the de-coupling capacitors. A 5kohm, 1%, resistor should connect BGREF to ground.

JTAG BOUNDARY SCAN

JTAG boundary scan supports board testing. Using boundary scan, the integrity of the digital paths between ICs on a board can be verified. This verification is supported by the ability to externally set the signals on the AK61584's digital output pins, and to externally read the signals present on the AK61584's input pins.

As shown in Figure 16, the JTAG hardware consists of data and instruction registers plus a Test Access Port (TAP) controller. Control of the TAP is achieved through signals applied to the Test Mode Select (J_TMS) and Test Clock (J_TCK) input pins. Data is shifted into the registers via the Test Data Input (J_TDI) pin, and shifted out of the registers via the Test Data Output (J_TDO) pin, again using J_TCK. The Instruction register defines which data register is included in the shift operation. Note that if J_TDI is left floating, an internal pull-up resistor forces the pin high.

JTAG Data Registers (DR)

The test data registers are: the Boundary-Scan Register (BSR), and the Bypass Register (BR).

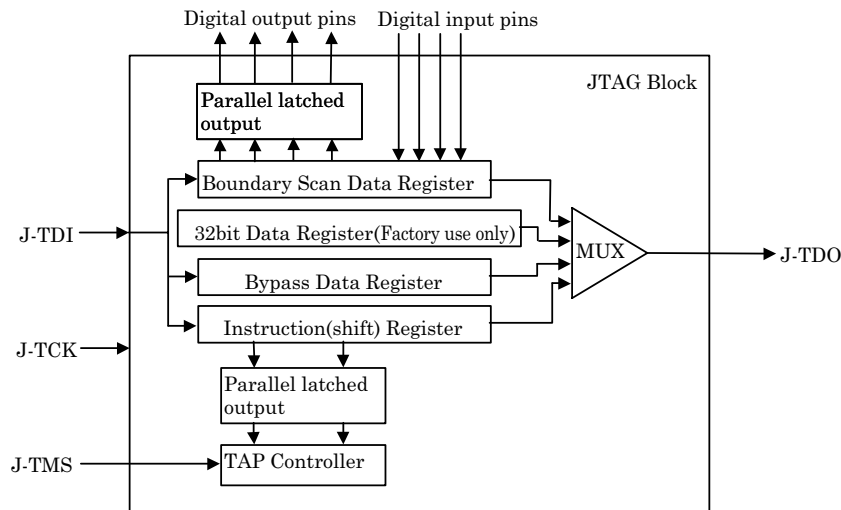

Figure 16. JTAG Circuitry Block Diagram

Boundary Scan Register: The BSR can be connected in parallel to all the digital I-O pins, and provides the mechanism for applying/reading test patterns to/from the board traces. The BSR is initialized and read using the instruction SAMPLE/PRELOAD. The bit ordering for the BSR is the same as the top-view packaged pin out, counter-clockwise beginning with PD1 (pin 15) and ending with LOS1 (pin 7), as shown in Table 6. The analog, oscillator, power, ground, ATTEN0, CLKE and MODE pins are not included as part of the boundary-scan register. ATTEN0, CLKE and MODE are not included because they are typically hard-wired to power or ground on a board.

All output pins are 3-state pins (logic high, logic low or high impedance); their value can be set via the PRELOAD/EXTEST instructions. Since outputs are all 3-state, 2 bits are required to specify the states of each output pin in the BSR. The first bit (which is shifted in first) contains the testing data which may be output on the pin. The second bit, which is shifted in following the first bit, selects between an output-enabled state (bit set to 1) or high-impedance state (bit set to 0). Thus, two J_TCK cycles are required to load testing data for each output pin.

Each input pin requires only 1 bit in the BSR.

The bi-directional pins, TNEG1/AIS1, TNEG2/AIS2, INT/RLOOP1, LOS1, LOS2, LLOOP1/SCLK, LLOOP2/SDO, TAOS1/SDI, TAOS2/SPOL, and the CON<0:2> pins have three bits in the BSR. The first bit shifted into the BSR captures the value of the pin. This pin may have its value set externally (if the third bit is 0) or set internally (if the third bit is 1). The second bit shifted into the BSR sets the output value. This value is output on the pin when the third bit is 1. The third bit configures the output driver as high-impedance (bit set to 0) or active (bit set to 1).

Note that the interrupt pin on the AK61584 has the ability of being a active high or active low signal. In host mode, the IPOL pin controls this functionality. During JTAG testing in host mode, the polarity of the INT pin will be determined by the state of the IPOL pin. The INT pin on the AK61584 should not be configured as an output by the JTAG BSR if the device is in hardware mode. Likewise, the INT pin should not be config-

ured as an input by the JTAG BSR if the device is in host mode.

Thus, the entire BSR is 62 bits long.

BSR bits	Pin Name	PIN #	Pad Type
1	PD1	15	input
2	IPOL,RLOOP2	33	input
3	PD2	34	input
4	CODER2	41	input
5-7	LOS2	42	bi-directional
8-10	TNEG2,AIS2	43	bi-directional
11	TPOS2,TDATA2	44	input
12	TCLK2	45	input
13-14	RNEG2,BPV2	46	output
15-16	RPOS2,RDATA2	47	output
17-18	RCLK2	48	output
19	CODER1	49	input
20	CON22	50	input
21-23	CON21	51	bi-directional
24-26	CON12	52	bi-directional
27-29	CON11	53	bi-directional
30-32	CON02	54	bi-directional
33-35	CON01	58	bi-directional
36-38	TAOS2	59	bi-directional
39-41	SDI,TAOS1	60	bi-directional
42-44	SDO,LLOOP1	61	bi-directional
45	SCLK,LLOOP2	62	input
46-48	INT,RLOOP1	63	bi-directional
49	CS,ATTEN1	64	input
50-51	RCLK1	1	output
52-53	RPOS1,RDATA1	2	output
54-55	RNEG1,BPV1	3	output
56	TCLK1	4	input
57	TPOS1,TDATA1	5	input
58-60	TNEG1,AIS1	6	bi-directional
61-63	LOS1	7	bi-directional

Table 6 Boundary Scan Register Contents

Bypass Register: The Bypass register consists of a single bit, and provides a serial path between J_TDI and J_TDO, bypassing the BSR. The provision of this register allows the bypassing of those segments of the board-level serial test register which are not required for a specific test. This also reduces test access times, by reducing the total number of shifts required from J_TDI to J_TDO.

JTAG Instructions and Instruction Register (IR)

The instruction register (2 bits) allows the instruction to be shifted into the circuit. The instruction is used to select the test to be performed or the data register to be accessed or both. The valid instructions are (LSB shifted in first):

IR CODE	INSTRUCTION
00	EXTEST
01	SAMPLE/PRELOAD
11	BYPASS

EXTEST Instruction: The EXTEST instruction allows testing of off-chip circuitry and board-level interconnect. EXTEST connects the BSR to J_TDI and J_TDO. The normal path between the AK61584 logic and its IO pins is broken; the signals on the output pins are loaded from the BSR; the signals on the input pins are loaded into the BSR.

SAMPLE/PRELOAD Instruction: The SAMPLE/PRE-LOAD instructions allows scanning of the boundary-scan register without interfering with the operation of the AK61584. This instruction connects the BSR to J_TDI and J_TDO. The normal path between the AK61584 logic and its IO pins is maintained; the signals on those IO pins is maintained; the signals on those 10 pins are loaded into the BSR. Additionally, this instruction can be used to latch values into the digital output pins.

BYPASS Instruction: The BYPASS instruction connects the minimum length, Bypass register between J_TDI and J_TDO, and allows data to be shifted in the shift-DR controller state.

Internal Testing Considerations

Note that the INTEST instruction is not supported because of the difficulty of performing significant internal tests using JTAG. The most complete internal test would involve inputting digital data on pins TCLK,

TPOS, TNEG, activating local loopback#2, and reading that same data out on pins RCLK, RPOS and RNEG. This test would include the full transmit path, the full receive path, and optionally, the jitter attenuator, and provides excellent test coverage of the functional blocks. However, this test is difficult to implement for two reasons.

First, TCLK and REFCLK must be clocked at specific frequencies, e.g., T1/E1+/-200 ppm for TCLK. If these frequency requirements are not met, the performance of the transmitter, clock recovery circuit and jitter attenuator is not guaranteed. It would be difficult with JTAG to toggle the TCLK input at the required rate.

Second, the loopback path includes two asynchronous blocks, clock recovery and jitter attenuator. Therefore, the exact time delay for a TPOS-input appearing on RPOS-output is variable, making output signature correlation difficult.

The one test that could be easily performed using an arbitrary clock rate on TCLK and REFCLK is local loopback#1, with jitter attenuator disabled. However, that test provides such limited fault coverage, that is only useful in determining if the device had been catastrophically destroyed. Alternatively, catastrophic destruction of the IC and/or surrounding board traces can be detected using EXTEST. Therefore, the INTEST instruction was viewed as providing little significant incremental testing capability, while adding to product complexity, and was not included in the AK61584.

JTAG TAP Controller

Figure 20 shows the state diagram for the TAP state machine. A description of each state follows. Note that the figure contains two main branches to access either the data or instruction registers. The value shown next to each state transition in this figure is the value present at J_TMS at each rising edge of J_TCK.

Shift-DR State

In this controller state, the test data register connected between J_TDI and J_TDO as a result of the current instruction shifts data on stage toward its serial output on each rising edge of J_TCK.

The instruction does not change in this state.

When the TAP controller is in this state and a rising edge is applied to J_TCK, the controller enters the Exit1-DR state if J_TMS is high or remains in the Shift-DR state if J_TMS is low.

Exit1-DR State

This is a temporary state. while in this state, if J_TMS is held high, a rising edge applied to J_TCK causes the controller to enter the Update-DR state, which terminates the scanning process. If J_TMS is held low and a rising edge is applied to J_TCK, the controller enters the Pause-DR state.

The test data register selected by the current instruction retains its previous value during this state. This instruction does not change in this state.

Pause-DR State

The pause state allows the test controller to temporarily halt the shifting of data through the test data register in the serial path between J_TDI and J_TDO. An example use of this state could be to allow tester to reload its pin memory from disk during application of a long test sequence.

The test data register selected by the current instruction retains its previous value during this state. The instruction does not change in this state.

The controller remains in this state as long as J_TMS is low. When J_TMS goes high and a rising edge is applied to J_TCK, the controller moves to the Exit2-DR state.

Exit2-DR State

This is a temporary state. While in this state, if J_TMS is held high, a rising edge applied to J_TCK causes the controller to enter the Update-DR state, which terminates the scanning process. If J_TMS is held low and a rising edge is applied to J_TCK, the controller enters the Shift-DR state.

The test data register selected by the current instruction retains its previous value during this state. The instruction does not change in this state.

Update-DR State

The Boundary Scan Register is provided with a latched parallel output to prevent changes at the parallel output while data is shifted in response to the EXTEST and SAMPLE/PRELOAD instructions. When the TAP controller is in this state and the Boundary Scan Register is selected, data is latched onto the parallel output of this register from the shift-register path on the falling edge of J_TCK. The data held at the latched parallel output does not change other than in this state.

All shift-register stages in the test data register selected by the current instruction retains their previous value during this state. The instructions does not change in this state.

Select-IR-Scan State

This is a temporary controller state. The test data register selected by the current instruction retains its previous state. If J_TMS is held low and a rising edge is applied to J_TCK when in this state, the controller moves into the Capture-IR state, and a scan sequence for the instruction register is initiated. If J_TMS is held high and a rising edge is applied to J_TCK, the controller moves to the Test-Logic-Reset state. The instruction does not change in this state.

Capture-IR State

In this controller state, the shift register contained in the instruction register loads a fixed value of “01” on the rising edge of J_TCK. this supports fault-isolation of the board-level serial test data path.

Data registers selected by the current instruction retain their value during this state. The instruction does not change in this state.

When the controller is in this state and a rising edge is applied to J_TCK, the controller enters the Exit1-IR state if J_TMS is held high, or the Shift-IR state if J_TMS is held low.

Shift-IR State

In this state the shift register contained in the instruction register is connected between J_TDI and J_TDO and shifts data one stage towards its serial output on each rising edge of J_TCK.

The test data register selected by the current instruction retains its previous value during this state. The instruction does not change in this state.

When the controller is in this state and a rising edge is applied to J_TCK, the controller enters the Exit1-IR state if J_TMS is held high, or re-mains in the Shift-IR state if J_TMS is held low.

Exit1-IR State

This is a temporary state. while in this state, if J_TMS is held high, a rising edge applied to J_TCK causes the controller to enter the Update-IR state, which terminates the scanning process. If J_TMS is held low and a rising edge is applied to J_TCK, the controller enters the Pause-IR state.

The test data register selected by the current instruction retains its previous value during this state. The instruction does not change in this state.

Pause-IR State

The pause state allow the test controller to temporarily halt the shifting of data through the instruction register.

The test data register selected by the current instruction retains its previous value during this state. The instruction does not change in this state.

The controller remains in this state as long as J_TMS is low. When J_TMS goes high and a rising edge is applied to J_TCK, the controller moves to the Exit2-IR state.

Exit2-IR State

This is a temporary state. While in this state, if J_TMS is held high, a rising edge applied to J_TCK causes the controller to enter the Update-IR state, which terminates the scanning process. If J_TMS is held low and a rising edge is applied to J_TCK, the controller enters the Shift-IR state.

The test data register selected by the current instruction retains its previous value during this state. The instruction does not change in this state.

Updata-IR State

The instruction shifted into the instruction register is latched onto the parallel output from the shift-register path on the falling edge of J_TCK. Once the new instruction has been latched, it becomes the current instruction.

Test data registers selected by the current instruction retain their previous value.

JTAG Application Examples

Figures 18 and 19 show examples of updating the instruction register and data registers.

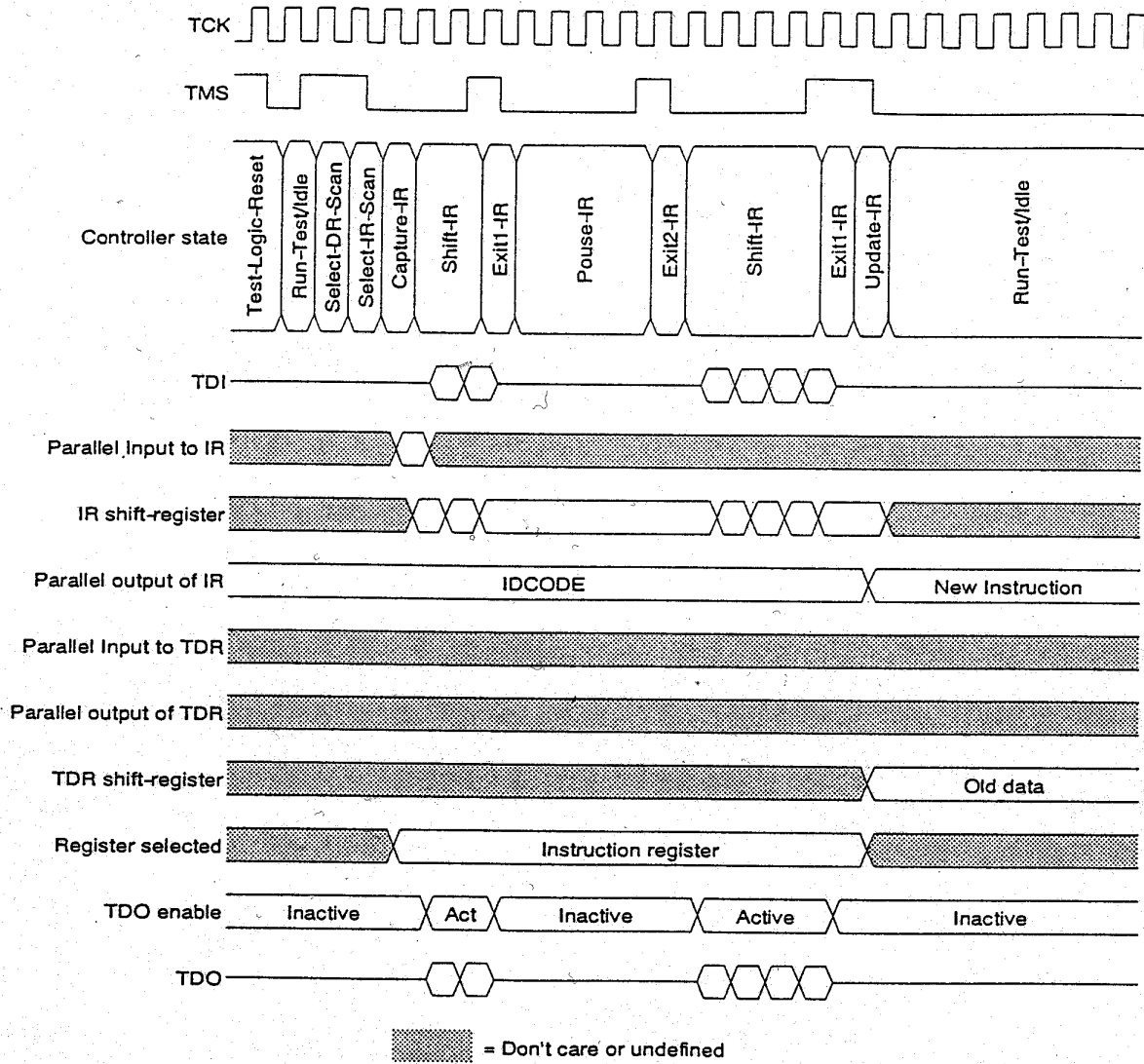

Figure 18. Test Logic Operation: Instruction Scan

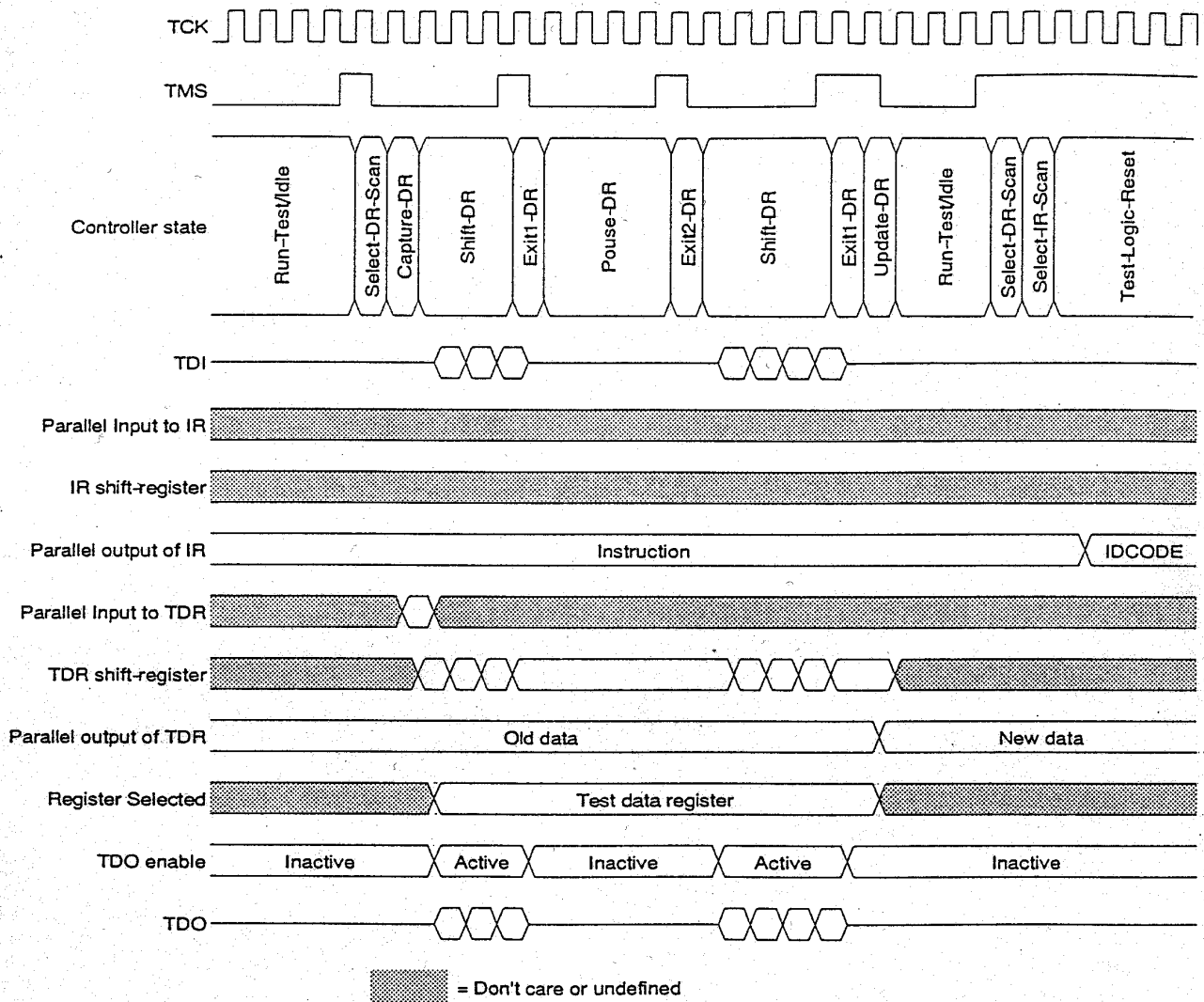
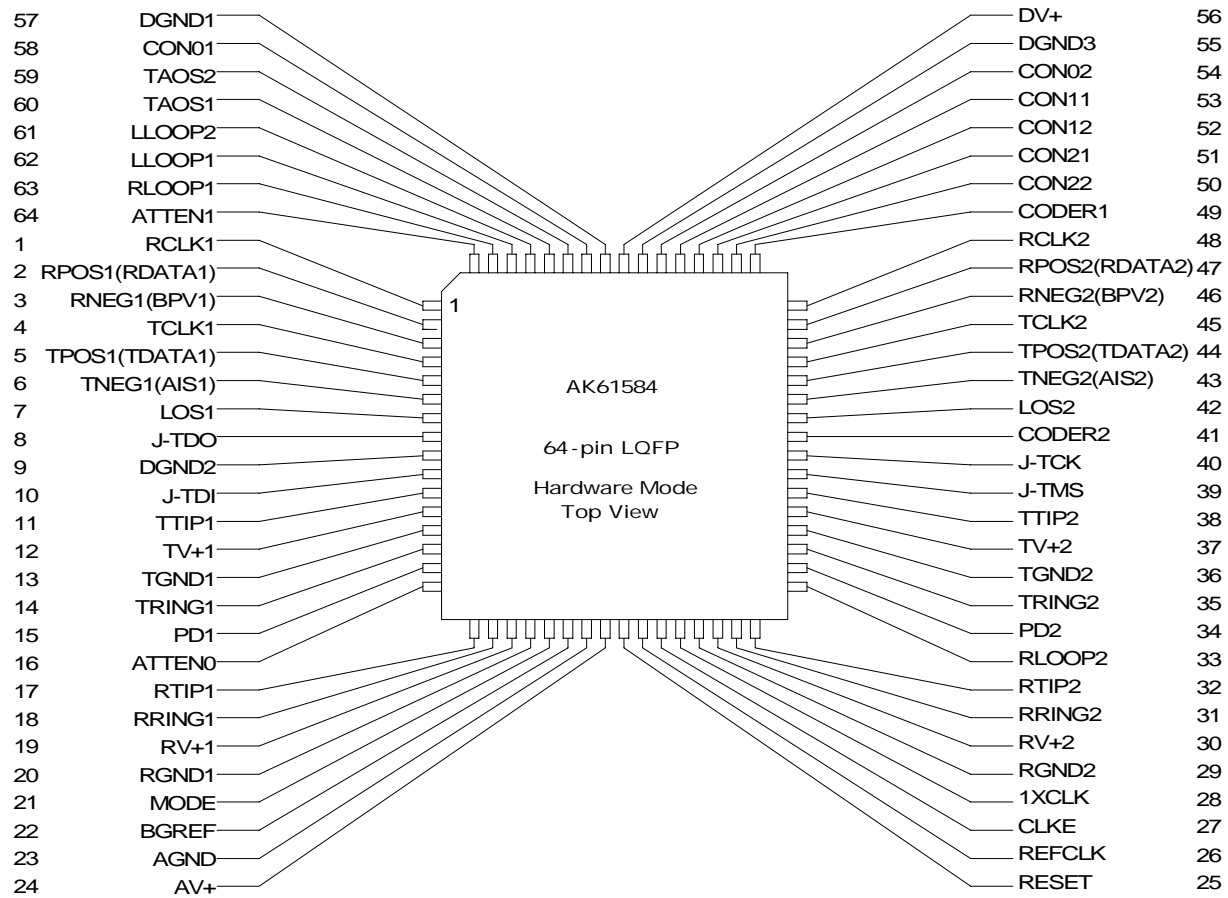
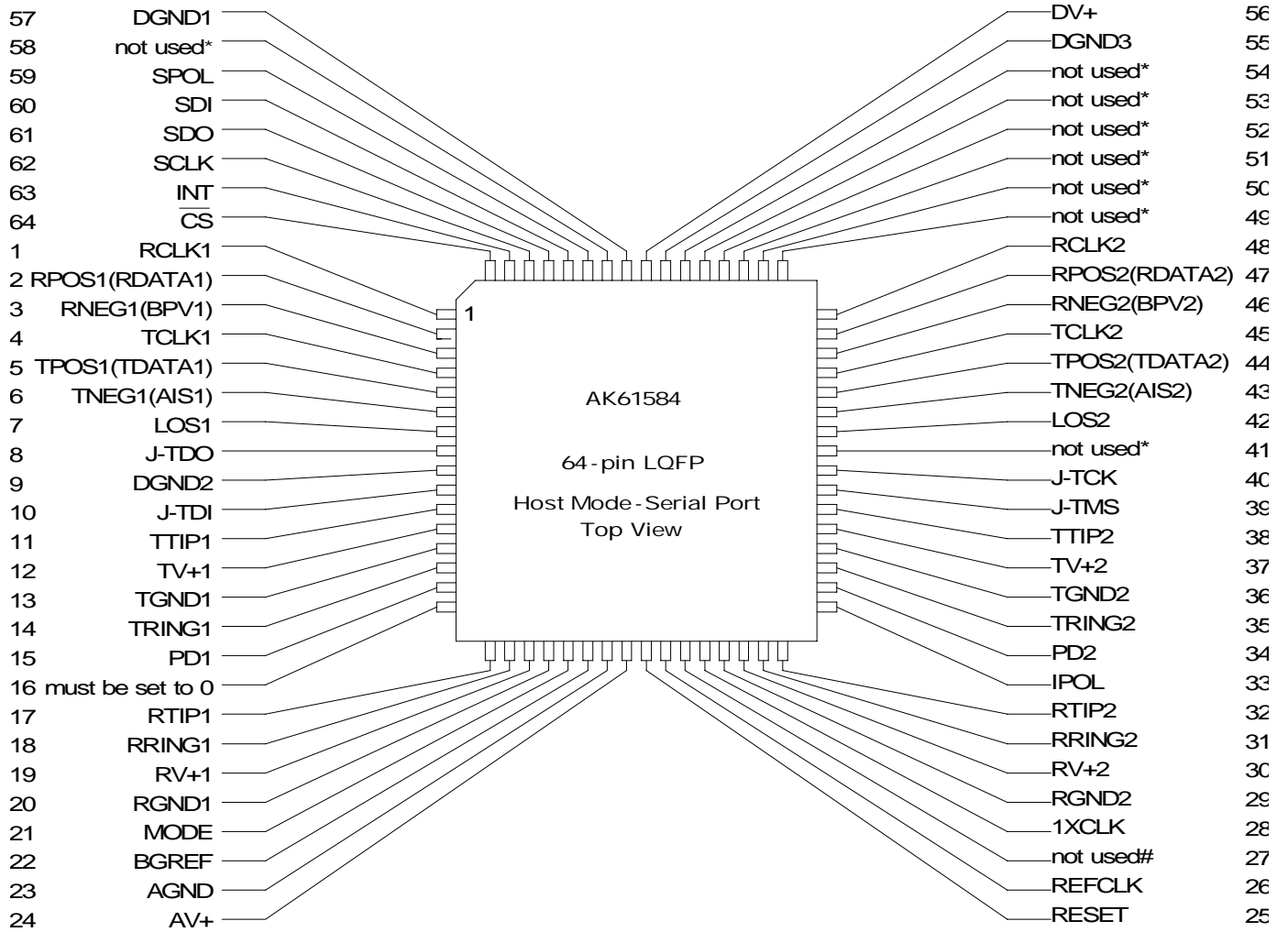

Figure 19. Test Logic Operation: Data Scan

PIN DESCRIPTION



PIN DESCRIPTION



Note:*not used pins are recommended to be tied to DGND
 #not used pins are recommended to be tied to AGND
 Pin 16 must be set to logic 0

Power Supplies

AGND-Ground, Analog, Pin 23.
Analog supply ground pin.

AV+ -Power Supply, Analog, Pin 24
Analog supply ground pin for internal bandgap reference, oscillator and internal clock multipliers

BGREF-Bandgap Reference, Pin 22
Used by the internal bandgap reference. This pin should be connected to ground by a 5k ohm resistor

DGND1, DGND2, DGND3 -Ground, Pins 57, 9, 55.
Power supply ground pin for the digital circuitry in both channels.

DV+ -Power Supply, Pin 56
Power supply pin for the digital circuitry in both channels.; typically +3.3 Volts referenced to DGND.

RGND1, RGND2 -Ground, Receiver, Pins 20, 29.
Power supply ground pins for the receivers.

RV+1, RV+2 -Power Supply, Receiver, Pins 19, 30.
Power supply pins for the analog circuitry in the receivers; typically +3.3 Volts referenced to RGND1 and RGND2.

TGND1, TGND2 -Ground, Transmit Drivers, Pin 13, 36
Power supply ground pins for the transmitters.

TV+1, TV+2 -Power Supply, Transmit Drivers, Pins 12, 37.
Power supply pins for the transmitter analog circuitry; typically +3.3 Volts references to TGND1 and TGND2.

Control Pins and Control Buses

ATTEN0 ATTEN1 -Jitter Attenuator Select, Pin 16, 64. (Hardware Mode)
selects, for both channels, which path has jitter attenuation (transmit/receive/neither).
See Table 4. In host mode, pin 16 must be tied to GND.

CLKE -Clock Edge, Pin 27. (Hardware mode)

CLKE controls RCLK polarity. Setting CLKE to logic 1 causes RPOS and RNEG (RDATA) to be valid on the falling edge of RCLK. Conversely, setting CLKE to logic 0 causes RPOS and RNEG (RDATA) to be valid on the rising edge of RCLK.

CODER1,CODER2-Coder enable, Pins 49, 41. (Hardware mode)

Setting CODER to logic 1 enables a coder (B8ZS or HDB3),setting CODER to logic 0 transparent mode enables.

CON01, CON11, CON21,
CON02, CON12, CON22 -Configuration Selection, Pins 58, 53, 51, 54, 52, 50.
(Hardware Mode)

Configures the transmitter (pulse shape, pulse width, pulse amplitude and driver impedance), receiver (slicing level), and coder (HDB3 vs B8ZS) as shown in Table 1. The CON_x1 pins control channel 1. The CON_x2 pins control channel 2. Both channels must operate at the same rate (both T1 or both E1).

CS -Chip Select, Pin 64. (Host modes)

Pin most transition from high to low to read or write the serial port.

INT -Receive Alarm Interrupt, Pin 63. (Host mode)

An interrupt is generated when a status register changes state to flag the host processor. INT is cleared by reading the status registers. The logic level for an active interrupt alarm is controlled by pin IPOL. INT is an open drain output and should be tied to the appropriate supply through a resistor.

IPOL -Interrupt Polarity, Pin 33. (Host mode)

IPOL controls INT polarity. Setting IPOL to logic 1 causes interrupts to be indicated by INT equal high. Setting IPOL to logic 0 causes interrupts to be indicated by INT equal to low.

LLOOP1, LLOOP2 -Local Loopback, Pin 62,61. (Hardware Mode)

Setting LLOOP to a logic 1 activates Local Loopback #1. TCLK and TPOS/TNEG (TDATA) are still transmitted unless overridden by a TAOS request. Inputs on RTIP and RRING are ignored.

MODE -Mode Select, Pin 21.

Setting MODE to logic 1 puts the line interface in the host mode. In the host mode, a serial interface is used to control the line interface and monitor its status.

Setting MODE to logic 0 puts the line interface in the hardware mode, where it is configured and monitored using discrete pins. MODE defined the function of pins shown across the top of the block diagram on the front page of the data sheet. Setting MODE to $AV+2$ volts will cause unpredictable results.

PD1, PD2 - Power Down, Pins 15, 34.

Setting PD1 or PD2 to logic 1 puts the channel 1 or channel 2 line interface, respectively, in a low power, inactive state. Setting PD1 or PD2 to logic 0 returns the selected channel to normal operation.

RESET -Reset, Pin 25.

Setting RESET to logic 1 resets the AK61584, clears the host-mode control registers, and then sets LOS high.

RLOOP1, RLOOP2 -Remote Loopback, Pins 63,33. (Hardware Mode)

Setting RLOOP to a logic 1 causes the recovered clock and data on both channels to be sent through the driver back to the line. The recovered signal is also sent to RCLK and RPOS/RNEG.(RDATA)

SCLK -Serial Clock, Pin 62. (Host mode)

Clock used to read or write the serial port registers. SCLK can be either high or low when the line interface is selected using the CS pin.

SDI -Serial Data Input, Pin 60. (Host mode)

Data for the on-chip register. Sampled on the rising edge of SCLK.

SDO -Serial Data Output, Pin 61. (Host mode)

Status and control information from the on-chip register. If SPOL is high SDO is valid on the rising edge of SCLK. If SPOL is low, SDO is valid on the falling edge of SCLK. This pin goes to a high-impedance state when the serial port is being written to or after bit D7 is output.

TAOS1,2 -Transmit All Ones Select, Pin 60, 59. (Hardware Mode)

Setting TAOS to a logic 1 causes continuous ones to be transmitted at the frequency determined by REFCLK.

Status

AIS1, AIS2 -All Ones Signal Detection, Pins 6, 43.

AIS goes high when an all-ones condition is detected using the detection criteria of less than nine zeros out of 8192 bit periods.

BPV1, BPV2 -Bipolar Violation Detection, Pins 3, 46.

BPV goes to a logic 1 for one bit period when a bipolar violation is detected in the received signal. B8ZS (or HDB3) zero substitutions are not flagged as bipolar violations if the B8ZS (or HDB3) decoder has been enabled.

LOS1, LOS2 -Loss of Signal, Pins 7, 42.

LOS goes to a logic 1 when 175 consecutive zeros have been detected. LOS returns to logic 0 when a 12.5% ones density signal returns.

SPOL -SDO Polarity Control, Pin 59. (Host mode)

setting SPOL to logic 1, causes SDO to be valid on the rising edge of SCLK. Setting SPOL to logic 0 causes SDO to be valid on the falling edge of SCLK.

Reference Clock

1XCLK -One-times Clock Frequency Select, Pin 28.

When 1XCLK is set to logic 1, REFCLK should be a 1.544 MHz for T1 or 2.048 MHz for E1 applications. When 1XCLK is set to logic 0, REFCLK should be an 8x clock, i.e., 12.352 MHz for T1 or 16.384 MHz for E1 applications.

REFCLK -External Reference Clock Input, Pin 26.

A reference clock for the receiver and jitter attenuator circuits of both channels. When 1XCLK is set to logic 1, REFCLK should be 1.544 MHz for T1 or 2.048 MHz for E1 applications. When 1XCLK is set to logic 0, REFCLK should be 12.352 MHz for T1 or 16.384 MHz for E1 applications.

T1/E1 Data Inputs And Outputs

RCLK1, RCLK2 -Receive Clock, Pins 1, 48.

RPOS1/RDATA1, RPOS2/RDATA2 -Receive Positive Data, Pins 2, 47.

RNEG1, RNEG2 -Receive Negative Data, -Pins 3, 46.

The receiver recovered clock and NRZ digital data is output on these pins. CLKE determines the clock edge for which RPOS and RNEG are stable and valid. See Table 3.

A positive pulse (with respect to ground) received on the RTIP pin generates a logic 1 on RPOS, and a positive pulse received on the RRING pin generates a logic 1 on RNEG. In coder mode, the decoded digital data stream is output on RDATA.

RTIP1, RRING1, RTIP2, RRING2 -Receive Tip, Receive Ring, Pins 17, 18, 32, 31.

The AMI receive signal is input to these pins. Step-down transformer is required on these inputs. Data and clock are recovered and output on RPOS/RNEG (RDATA) and RCLK.

TCLK1, TCLK2 -Transmit Clock, Pin 4, 45.

TPOS1/TDATA1, TPOS2/TDATA2 -Transmit Positive Data, Pins 5, 44.

TNEG1, TNEG2 -Transmit Negative Data, -Pins 6, 43.

Inputs for clock and data to be transmitted. The signal is driven on to the line through TTIP and TRING. TPOS and TNEG are sampled on the falling edge of TCLK. A TPOS input causes a positive pulse to be transmitted, while a TNEG input causes a negative pulse to be transmitted. In coder mode, the un-encoded digital data stream is input on TDATA.

TTIP1, TRING1, TTIP2, TRING2 -Transmit Tip, Transmit Ring, Pins 11, 14, 38, 35.

The AMI signal is driven to the line through these pins. This output is designed to drive the primary of the recommended transformer. In transparent mode, TPOS drives TTIP, and TNEG drives TRING. In coder mode, TDATA drives TTIP and TRING.

Test

J_TCLK-JTAG Test Clock, Pin 40.

Data on pins J_TDI and J_TDO is valid on the rising edge of J_TCK. When J_TCK is stopped low, all JTAG registers remain unchanged.

J_TMS -JTAG Test Mode Select, Pin 39.

An active high signal on this pin enables the JTAG serial port. Connected to an internal pull-up resistor.

J_TDI -JTAG Test Data In, Pin 10.

JTAG data is shifted into the AK61584 via this pin. Connected to an internal pull-up resistor. Data should be stable on the rising edge of J_CLK.

J_TDO -JTAG Test Data Out, Pin 8.

JTAG data is shifted out of the AK61584 via this pin. This pin is active except when JTAG testing is in progress. J_TDO will be updated on the falling edge of J_TCK.

Marking

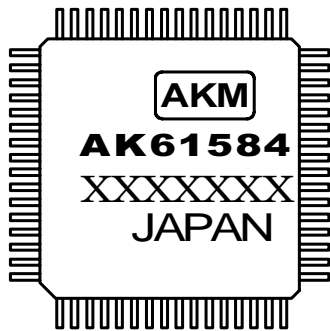

- (1) AKM Logo.
- (2) Marketing Code :AK61584
- (3) Date Code :7digits XXXXXXXX
- (4) Country of Origin :JAPAN

Outline Dimensions

