

## Applications Using the GTLP10B320

### Abstract

The GTLP10B320 is a GTLP (Gunning Transceiver Logic Plus) device that offers features specifically designed to address unique applications issues. This device is an important innovation in backplane drivers, allowing for split TTL inputs and outputs as well as an internal feedback path. These features can add to the performance and/or diagnostic capabilities of a system.

### Features

Independent TTL inputs and outputs on the new GTLP10B320 add versatility to numerous GTLP applications. Current GTLP devices have an A Port for TTL input and a B Port for GTLP output under A Port to B Port operation, and a B Port GTLP input with an A Port TTL output under B Port to A Port operation. In some applications this single-set bi-directional TTL I/O may be an inconvenient feature. In these applications, it may be more convenient to have independent inputs and outputs.

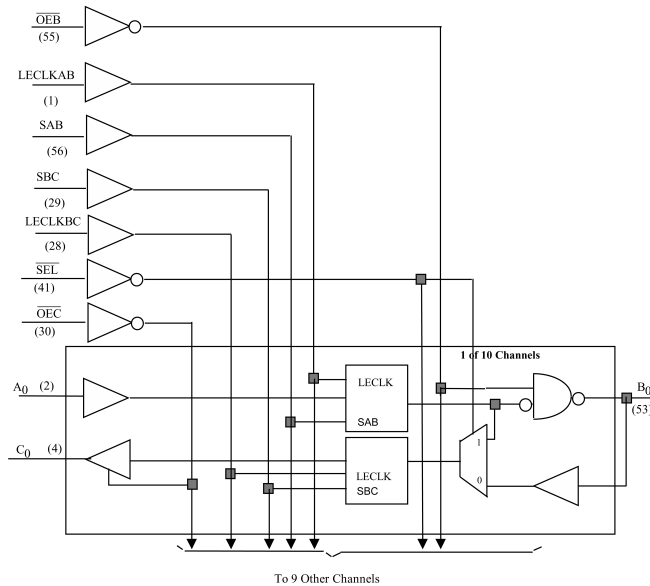

FIGURE 1. GTLP10B320 Logic Diagram

In many cases, designers put two lines in parallel forming one node on each of the TTL input pins, allowing the TTL driver to send data on one line and receive data on another. Another configuration uses one GTLP device to send data and another GTLP device to receive data, adding size and cost to the project. In these configurations, the GTLP10B320 can replace two current GTLP devices where data throughput is not critical.

Another important feature of the GTLP10B320's split input is a feedback path to monitor the master inputs on the A

Port. This allows another device to receive the TTL feedback to ensure the correct data is being distributed to the bus. This internal feedback path is selected with SEL set to LOW. When SEL is LOW and no data is sent out onto the backplane, OEB is HIGH or 3-stated and data is simply following the feedback path from the A Port to the C Port. After confirming that the correct TTL data is at the A Port, toggling OEB to LOW enables the GTLP B Port, and data is released onto the backplane.

## Operation and Specifications

The general operation of the GTLP10B320 is similar to other GTLP devices designed to the JEDEC standard JESD8-3, with features such as:

- Open drain technology on GTLP, capable of sinking +50mA
- Voltage swing of <math><1V</math>, low power consumption and EMI
- User ability to adjust variables ( $R_{TERM}$ ,  $V_{TT}$ , and  $V_{REF}$ ) to optimize backplane characteristics
- Bushhold on the TTL A Port, eliminating need for pull-up resistors on TTL side
- Incident wave switching, enabling higher throughput
- Outputs are high impedance during power up/down for live insertion
- Modes of operation include latched/transparent and registered

Figure 2 illustrates the five basic modes possible for the GTLP10B320. Register and latch options are available for

each mode using the latch enable pin LECLK and the directional select pins SAB and SBC. For additional details refer to the datasheet.

The GTLP10B320 is designed for optimal performance into a 10pF lumped load. This better characterizes its performance in a true distributed load backplane, which is the most common application. AC characteristics are specified with both a 10pF lumped load and the standard 30pF lumped load in the datasheet. This provides the designer with more realistic representation of how the device will perform in a system as well as the ability to make comparisons to other GTLP devices.

## Summary

The GTLP10B320 is an important innovation in backplane drivers that allows for split TTL inputs and outputs as well as an internal feedback path. These two features can add to the performance and/or diagnostic capabilities of a system.

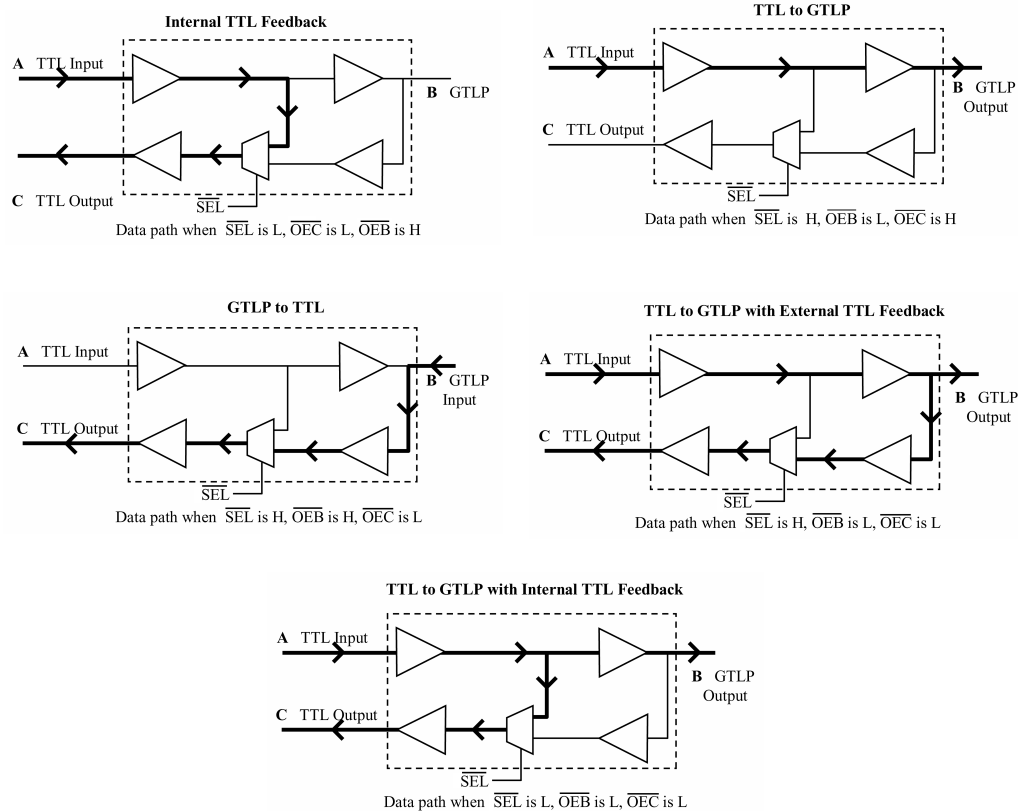

**FIGURE 2. GTLP10B320 Operation Modes (1-Bit Shown)**

Fairchild does not assume any responsibility for use of any circuitry described, no circuit patent licenses are implied and Fairchild reserves the right at any time without notice to change said circuitry and specifications.

**LIFE SUPPORT POLICY**

FAIRCHILD'S PRODUCTS ARE NOT AUTHORIZED FOR USE AS CRITICAL COMPONENTS IN LIFE SUPPORT DEVICES OR SYSTEMS WITHOUT THE EXPRESS WRITTEN APPROVAL OF THE PRESIDENT OF FAIRCHILD SEMICONDUCTOR CORPORATION. As used herein:

1. Life support devices or systems are devices or systems which, (a) are intended for surgical implant into the body, or (b) support or sustain life, and (c) whose failure to perform when properly used in accordance with instructions for use provided in the labeling, can be reasonably expected to result in a significant injury to the user.
2. A critical component in any component of a life support device or system whose failure to perform can be reasonably expected to cause the failure of the life support device or system, or to affect its safety or effectiveness.

[www.fairchildsemi.com](http://www.fairchildsemi.com)