

■ Absolute Maximum Rating (Ta=25°C)

Parameter	Symbol	Rating	Unit
Supply voltage	V _{CC}	6	V
Motor supply voltage	V _M	20	V
Motor supply current <small>Note 1)</small>	I _M	±1.5	A
Output terminal voltage <small>Note 1)</small>	V _o	20	V
Terminal voltage <small>Note 2)</small>	V _{in}	V _{CC}	V
Terminal 14 current	I ₁₄	-100	mA
Power dissipation	P _D	1400	mW
Operating ambient temperature	T _{op}	-20 to +70	°C
Storage temperature	T _{stg}	-55 to +150	°C

Note 1) Pin No. = 1, 3, 23 Note 2) Pin No. = 5, 6, 7, 8, 9, 10, 11, 15, 16, 19

■ Recommended Operating Range (Ta=25°C)

Parameter	Symbol	Range
Operating supply voltage	V _{CC}	4.5V to 5.5V
Motor supply current	V _M	6V to 18V

■ Electrical Characteristics (Ta=25°C)

Parameter	Symbol	Condition	min	typ	max	Unit
Supply current	I _{CC}	Current of hall element power supply excluded	—	—	15	mA
Torque command reference voltage	ECR		2	—	3.5	V
Torque command voltage	EC		0.5	—	4	V
Torque command input offset voltage	EC _{offset}		-150	—	150	mV
Torque command dead zone	EC _{DZ}		50	—	150	mV
Output idle voltage	ATC _{idle}		—	—	4	mV
Input/Output gain	G _{io}		0.61	0.68	0.75	multiple
Output maximum voltage	ATC _{max}		0.75	—	—	V
Normal rotation command voltage	ED _F		—	—	0.9	V
Stop command voltage	ED _S		1.3	—	3	V
Reverse rotation command voltage	ED _R		3.5	—	—	V
Hall element input offset voltage	H _{offset}		-8	—	8	mV
Lower-side output voltage (1)	V _{N (1)}	ATC=68mV	0.44	—	0.88	V
Lower-side output voltage (2)	V _{N (2)}	E _{CR} =2.5V E _C =0.5V	2	—	3.5	V
TL-CS offset voltage	ΔTL	TL=600mV	5	—	40	mV
Ripple cancellation ratio	α	ATC=68mV ATC=47mV	4	—	18	%
Hall element supply voltage	VH ⁺	I _{VH⁺} = -20mA	2.6	2.85	3.2	V
Hall element input allowable voltage	H _{in}		1.2	—	3.5	V
Switching supply control output	V _S	EC=BCR, V _M -A1=1.3V	2.1	2.5	2.9	V
Switching supply control output gain	G _{VS}		-3.4	—	-2.3	multiple



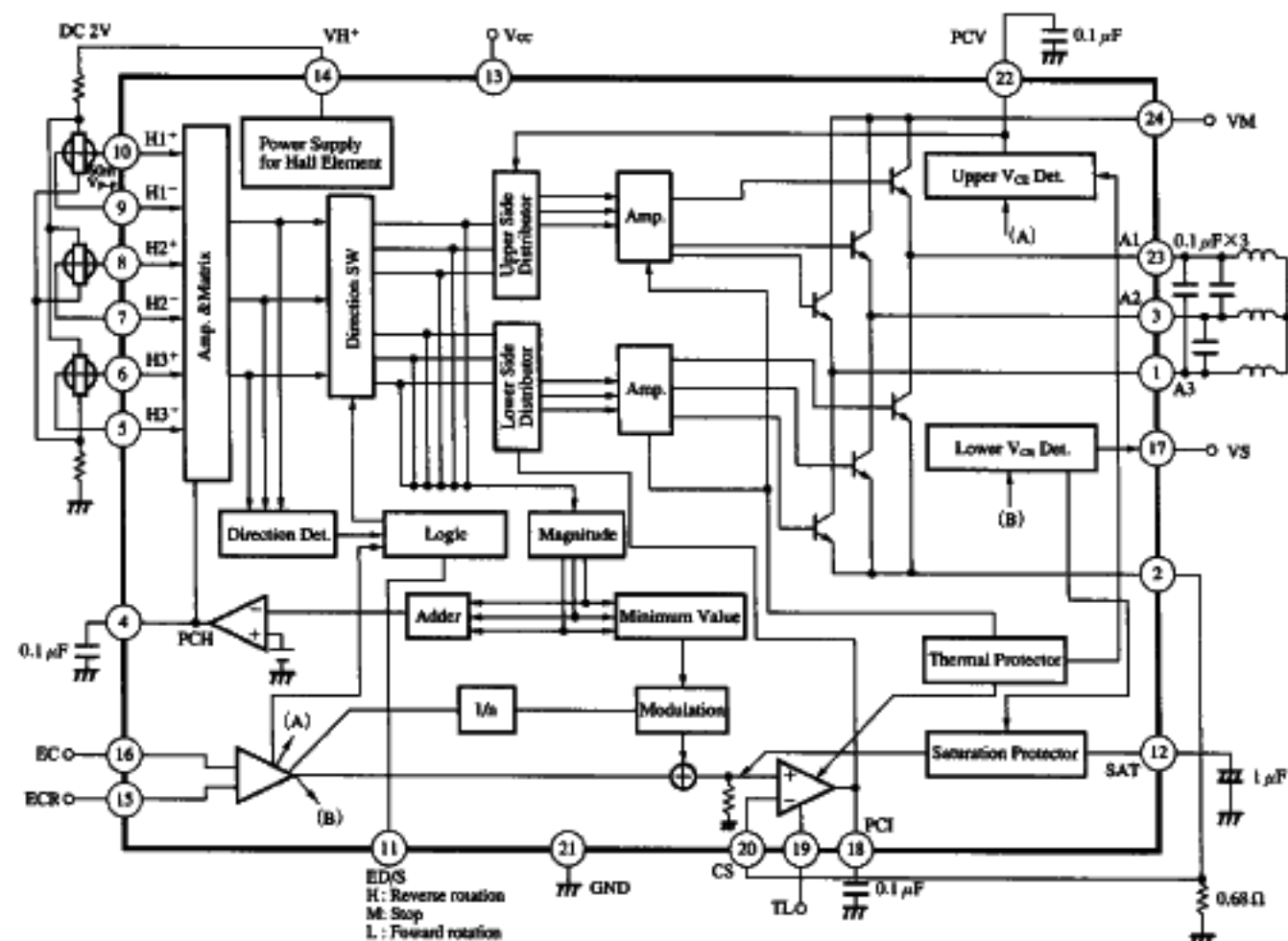

Application Diagram

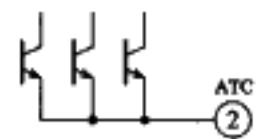

Pin Descriptions

Pin No.	Pin name	Standard waveform	Description	Equivalent circuit
1 3 23	A3: Drive output 3 A2: Drive output 2 A1: Drive output 1		Motor coil connected	

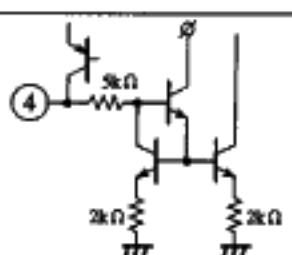
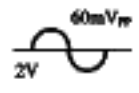
■ Pin Descriptions

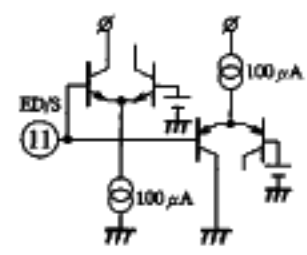
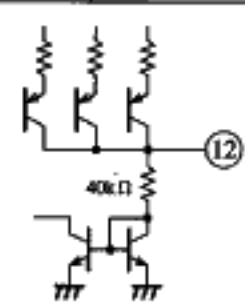
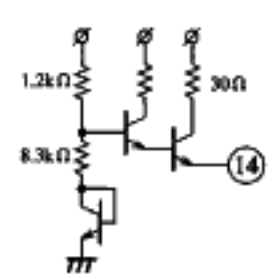
Pin No.	Pin name	Standard waveform	Description	Equivalent circuit
2	ATC : Total current output		The total current of the output transistor is outputted.	
4	PCH : Hall amp. phase compensation		Terminal for phase compensation of AGC loop of Hall amp.	
5 6 7 8 9 10	H ₅ ⁻ : Hall element input H ₆ ⁺ : Hall element input H ₇ ⁻ : Hall element input H ₈ ⁺ : Hall element input H ₉ ⁻ : Hall element input H ₁₀ ⁺ : Hall element input		Hall Element output of motor is inputted.	
11	ED/S : Direction command input terminal		Terminal for directing the rotation direction and stop of the motor with 3-value input.	
12	SAT : Saturation prevention phase compensation		Terminal for phase compensation of the loop preventing the saturation of output transistor.	
13	V _{CC} : Power supply terminal		The terminal for inputting the supply voltage.	
14	V _H ⁺ : Hall element power supply		The terminal for outputting the supply voltage for Hall element.	

Pin Description (cont.)

Pin No.	Pin name	Standard waveform	Description	Equivalent circuit
15	ECR : Torque command reference input terminal		Terminal for inputting the reference voltage of torque command.	
16	EC : Torque command input terminal		Terminal for inputting the torque command voltage.	
17	V_S : Switching power supply control output		Terminal outputting the voltage proportional to V_{CE} of source side output transistor to control the switching power supply.	
18	PCI : Current feedback system phase compensation		Terminal for phase compensation of the system which controls the current of the sink side output transistor.	
19	TL : Torque limit terminal		Terminal setting the maximum voltage of the ATC terminal.	
20	CS : Current detection terminal		Terminal connected to the ATC terminal, for inputting the value which is current-detected by the resistor.	
21	GND :		Ground terminal	
22	PCV : Voltage feedback system phase compensation		Terminal for phase compensation of the system which controls the source side output transistor.	
24	V_M : Motor power supply terminal		Terminal inputting the motor power supply.	

Phase of Hall Input and Output Current

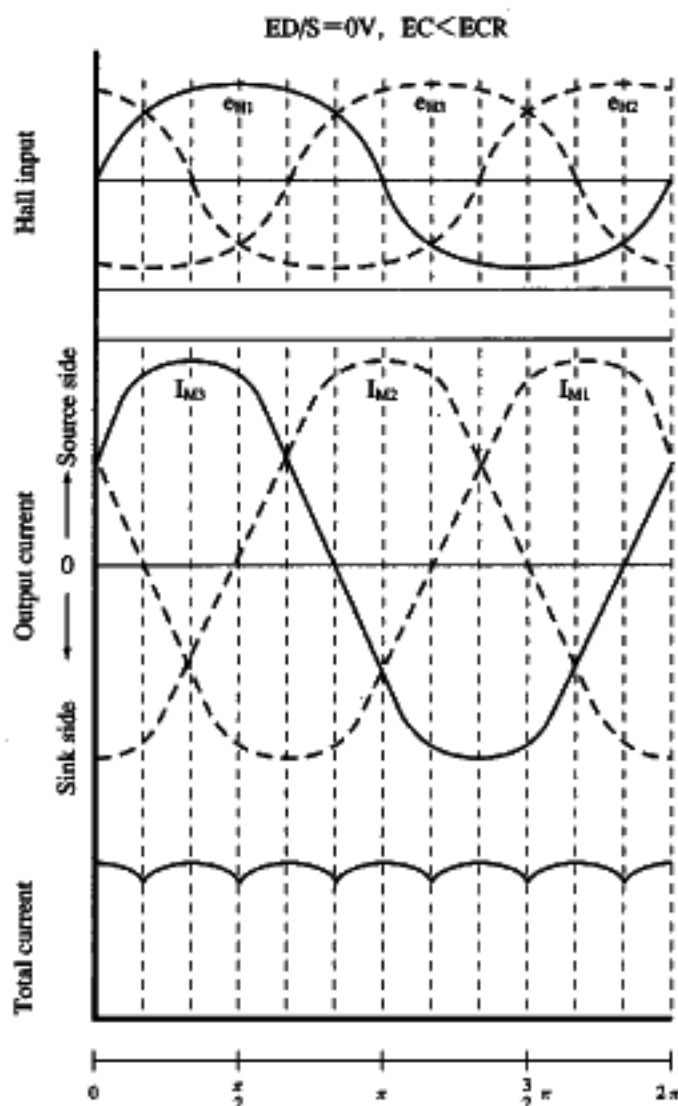

Torque Direction Setting Logic

The direction of generated torque is determined according to the following information.

- Information from the rotation direction detection circuit : \overline{ER}

High : $H_1 \rightarrow H_3 \rightarrow H_2$

- Brake information from the torque command circuit : \overline{EA}

High : $BCR > EC$

- Rotation direction command : \overline{ED}

High : $H_1 \rightarrow H_3 \rightarrow H_2$

$\therefore ED/S = 0V$ is set for $H_1 \rightarrow H_3 \rightarrow H_2$ (normal rotation)

- Direction of generated torque : \overline{EP}

Generated torque rotating in the direction : High : $H_1 \rightarrow H_3 \rightarrow H_2$

\overline{EP} is determined by \overline{ER} , \overline{EA} and \overline{ED} as follows :

$$\overline{EP} = \overline{ED} \cdot \overline{EA} + \overline{ER} \cdot \overline{EA}$$

	\overline{EA}	\overline{EA}		\overline{EA}
\overline{ED}	H	H	H	L
\overline{ED}	H	L	L	L
	\overline{ER}		\overline{ER}	

Carnot map of torque direction setting logic