

APL3015MBC BLUE

### Features

- 3.0mmx1.5mm SMT LED, 1.4mm THICKNESS.
- LOW POWER CONSUMPTION.
- WIDE VIEWING ANGLE.
- IDEAL FOR BACKLIGHT AND INDICATOR.
- VARIOUS COLORS AND LENS TYPES AVAILABLE.
- INNER LENS TYPE
- PACKAGE : 2000PCS / REEL.

### Description

The Blue source color devices are made with GaN on SiC Light Emitting Diode.

Static electricity and surge damage the LEDs. It is recommended to use a wrist band or anti-electrostatic glove when handling the LEDs.

All devices, equipment and machinery must be electrically grounded.

### Package Dimensions

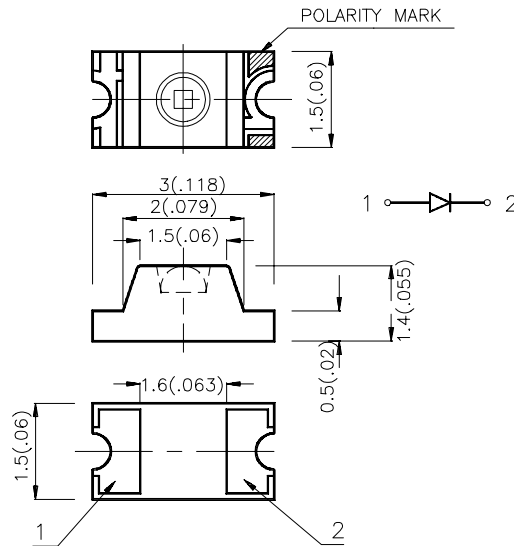

#### Notes:

1. All dimensions are in millimeters (inches).
2. Tolerance is  $\pm 0.2(0.0079)$  unless otherwise noted.
3. Lead spacing is measured where the lead emerge package.
4. Specifications are subject to change without notice.

## Selection Guide

Part No.	Dice	Lens Type	Iv (mcd) @ 20 mA		Viewing Angle
			Min.	Typ.	2θ1/2
APL3015MBC	BLUE ( GaN )	WATER CLEAR	7	20	70°

Note:

1. θ1/2 is the angle from optical centerline where the luminous intensity is 1/2 the optical centerline value.

## Electrical / Optical Characteristics at T<sub>A</sub>=25°C

Symbol	Parameter	Device	Typ.	Max.	Units	Test Conditions
λ <sub>peak</sub>	Peak Wavelength	Blue	430		nm	IF=20mA
λ <sub>D</sub>	Dominate Wavelength	Blue	455		nm	IF=20mA
Δλ <sub>1/2</sub>	Spectral Line Halfwidth	Blue	60		nm	IF=20mA
C	Capacitance	Blue	65		pF	VF=0V;f=1MHz
V <sub>F</sub>	Forward Voltage	Blue	4.0	4.5	V	IF=20mA
I <sub>R</sub>	Reverse Current	Blue		10	uA	VR = 5V

## Absolute Maximum Ratings at T<sub>A</sub>=25°C

Parameter	Blue	Units
Power dissipation	105	mW
DC Forward Current	30	mA
Peak Forward Current [1]	150	mA
Reverse Voltage	5	V
Operating Temperature	-40°C To +80°C	
Storage Temperature	-40°C To +85°C	

Note:

1. 1/10 Duty Cycle, 0.1ms Pulse Width.

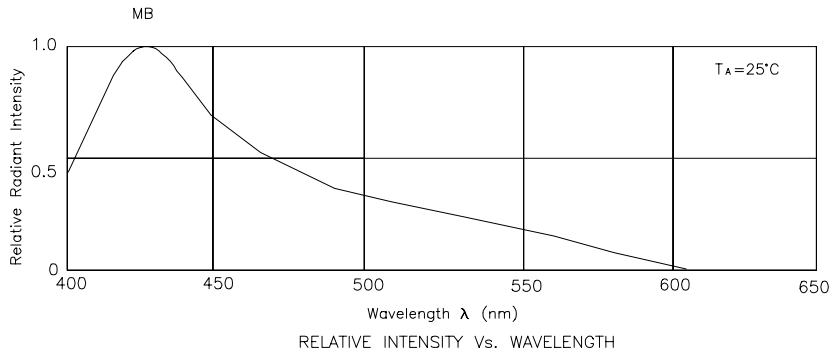

## Blue APL3015MBC

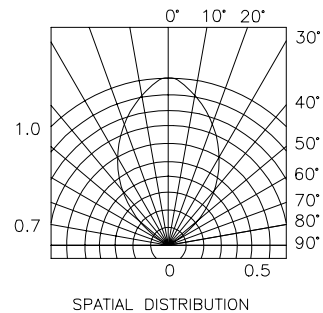
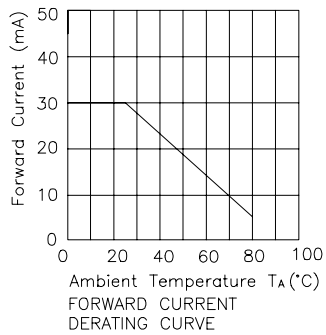
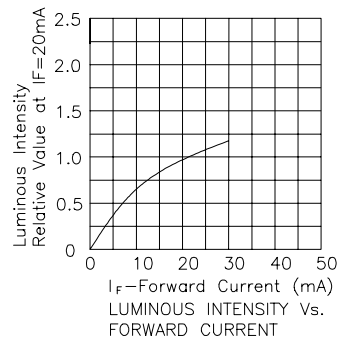
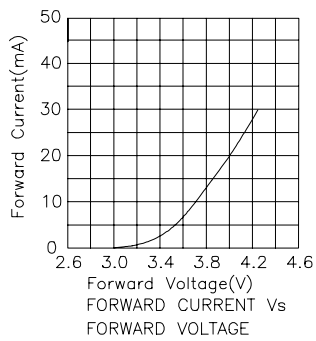

## APL3015MBC SMT Reflow Soldering Instructions

Number of reflow process shall be less than 2 times and cooling process to normal temperature is required between first and second soldering process.

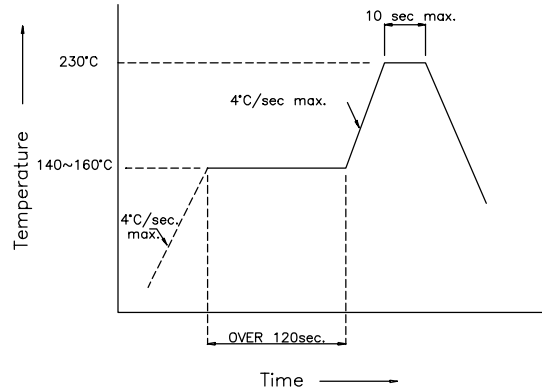

## Recommended Soldering Pattern (Units : mm)

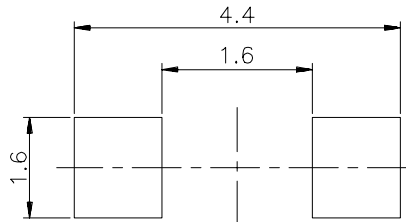

## Tape Specifications (Units : mm)

