

# ARX 4418 & 4417 Variable Amplitude Transceivers for MACAIR A3818, A5690, A5232, A4905 & MIL-STD-1553

## Features

- ARX 4418 Transceiver meets MIL-STD-1553A&B, Macair A3818, A4905, A5232 and A5690 specs
- ARX 4417 Transceiver meets MIL-STD-1553 specs
- Operates with  $\pm 15$  Volts to  $\pm 12$  Volts power supply
- Voltage source output for higher bus drive power
- Plug-in, flat package or low profile flat package
- Monolithic construction using linear ASICs
- Variable receiver threshold capability
- Variable TX Amplitude
- Processed and screened to Mil-STD-883 specs
- DESC SMD (Standard Military Drawing)

**AEROFLEX**  
CIRCUIT TECHNOLOGY  
www.aeroflex.com

## General Description

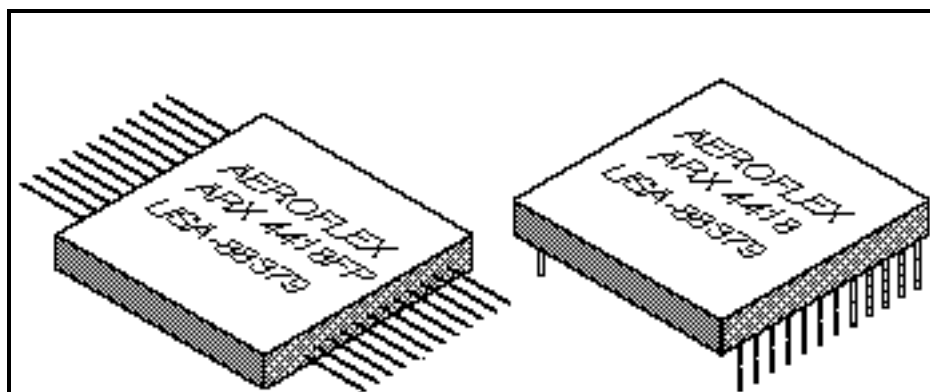
The Aeroflex Laboratories transceiver models ARX 4418 and ARX 4417 are new generation monolithic transceivers which provide full compliance with Macair and MIL-STD-1553 data bus requirements while providing variable amplitude control.

The model ARX 4418 and model ARX 4417 perform the front-end analog function of inputting and outputting data through a transformer to a MIL-STD-1553 or Macair data bus. The ARX 4418 can be considered a "Universal" Transceiver in that it is compatible with MIL-STD-1553A, B, Macair A-3818, A-4905, A-5232 and A-5690. The ARX 4417 is compatible with MIL-STD-1553A/B.

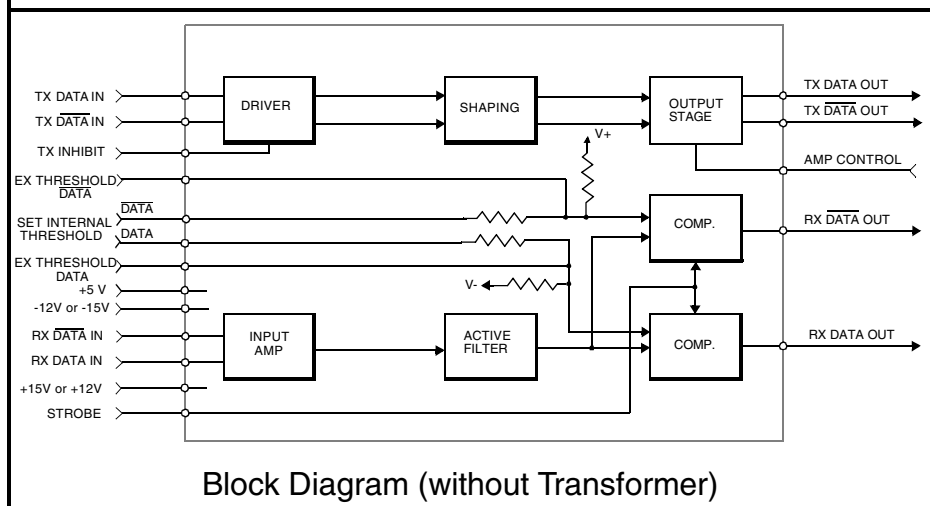
Design of these transceivers reflects particular attention to active filter performance. This results in low bit and word error rate with superior waveform purity and minimal zero crossover distortion. The ARX4418 series active filter design has additional high frequency roll-off to provide the required Macair low harmonic distortion waveform without increasing the pulsedelay characteristics significantly.

Efficient transmitter electrical and thermal design provides low internal power dissipation and heat rise at high and well as low duty cycles.

Variable amplitude is adjusted with 0–10 Vdc on the control pin. An optional receiver input threshold adjustment can be accomplished by the use of the "Set Internal Threshold" terminals.



ARX 4418FP/4418 Transceivers



Block Diagram (without Transformer)

## Transmitter

The Transmitter section accepts bi-phase TTL data at the input and when coupled to the data bus with a 1:1 transformer, isolated on the data bus side with two 52.5 Ohm fault isolation resistors, and loaded by two 70 Ohm terminations plus additional receivers, the data bus signal produced is 7.0 volts minimum P-P at A-A'. (See Figure 5.) When both DATA and  $\overline{\text{DATA}}$  inputs are held low or high, the transmitter output becomes a high impedance and is "removed" from the line. In addition, an overriding "INHIBIT" input provides for the removal of the transmitter output from the line. A logic "1" applied to the "INHIBIT" takes

priority over the condition of the data inputs and disables the transmitter. (See Transmitter Logic Waveforms, Figure 1.)

The transmitter utilizes an active filter to suppress harmonics above 1MHz to meet Macair specifications A-3818, A-4905, A-5232 and A-5690. The transmitter may be safely operated for an indefinite period at 100% duty cycle into a data bus short circuit.

## Receiver

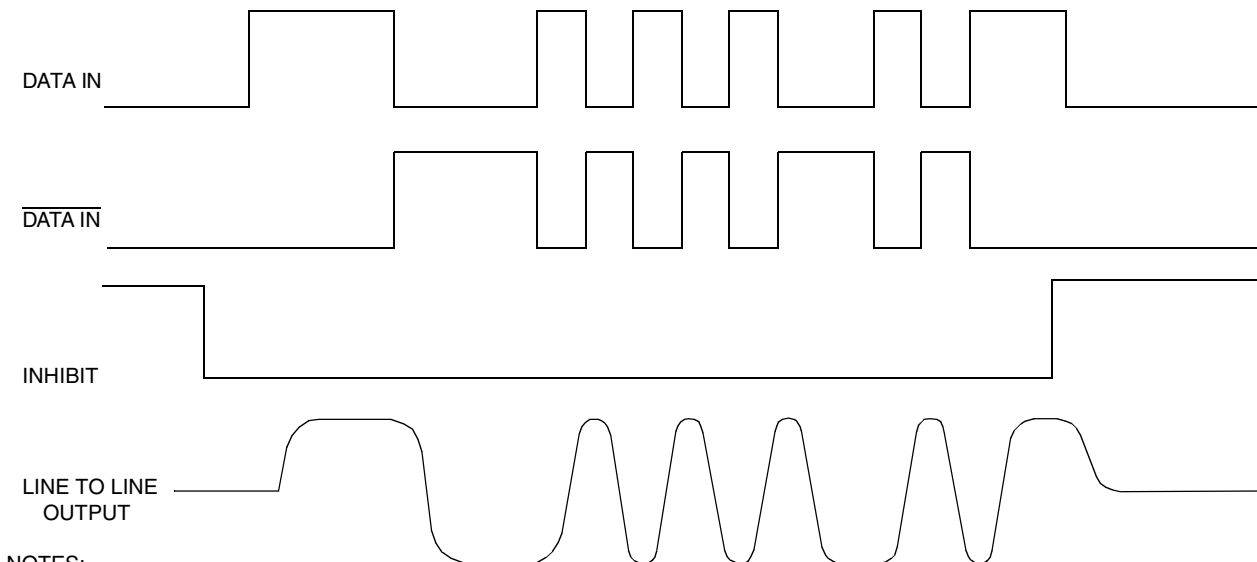
The Receiver section accepts bi-phase differential data at the input and produces two TTL signals at the output. The outputs are DATA and  $\overline{\text{DATA}}$ , and represent positive and negative excursions of the input

beyond a pre-determined threshold. (See Receiver Logic Waveforms, Figure 2.)

The internal threshold is nominally set to detect data bus signals exceeding 1.05 Volts P-P and reject signals less than 0.6 volts P-P when used with a 1:1 turns ratio transformer. (See Figure 5 for transformer data and typical connection.) This threshold setting can be held by grounding the appropriate pins or modified with the use of external resistors.

A low level at the Strobe input inhibits the DATA and  $\overline{\text{DATA}}$  outputs. If unused, a 2K pull-up to +5 Volts is recommended.

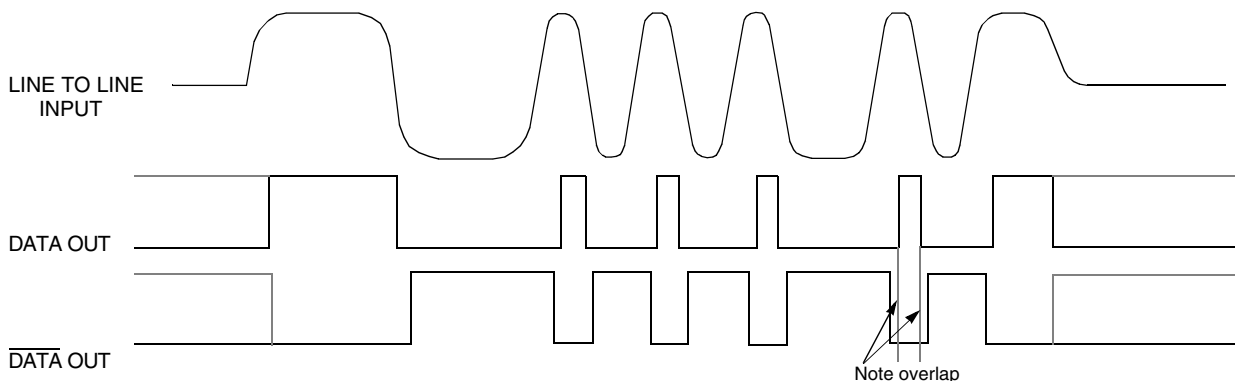
**Figure 1 – Transmitter Logic Waveforms**



**NOTES:**

1. Line to line waveforms illustrate Macair signals, MIL-STD-1553 signals are trapezoidal
2. DATA and  $\overline{\text{DATA}}$  inputs must be complementary waveforms or 50% duty cycle average, with no delays between them.
3. DATA and  $\overline{\text{DATA}}$  must be in the same state during off time (both high or low).

**Figure 2 – Receiver Logic Waveforms**



**NOTE:** Waveforms shown are for normally low devices. For normally high receiver output level devices, the receiver outputs are swapped as shown by the dashed lines

## Absolute Maximum Ratings

Operating Case Temperature	-55°C to +125°C	
Storage Case Temperature	-65°C to +150 °C	
Power Supply Voltages	±15 V P.S. to ±18V MAX	+5 V P.S. to +7V MAX
Logic Input Voltage	-0.3 V to +5.5 V	
Receiver Differential Input	±40 V	
Receiver Input Voltage (Common Mode)	±10V	
Driver Peak Output Current	300 mA	
Total Package Power Dissipation over the Full Operating Case Temperature Range	2.4 Watts	
Power Dissipation for hottest die, (100% duty cycle)	600 mW	
Maximum junction to case temperature rise for the hottest device (100 % duty cycle)	36°C	
Junction-Case, Thermal Resistance for hottest device	60°C/W	

## Electrical Characteristics, Transmitter Section

### Input Characteristics, TX DATA in or TX DATA $\bar$ in

Parameter	Condition	Symbol	Min	Typ	Max	Unit
"0" Input Current	V <sub>IN</sub> = 0.4 V	I <sub>ILD</sub>		-0.2	-0.4	mA
"1" Input Current	V <sub>IN</sub> = 2.7 V	I <sub>IHD</sub>		1.0	40	μA
"0" Input Voltage		V <sub>ILD</sub>			0.7	V
"1" Input Voltage		V <sub>IHD</sub>	2.0			V

### Inhibit Characteristics

"0" Input Current	V <sub>IN</sub> = 0.4V	I <sub>ILI</sub>	-	-0.2	-0.4	mA
"1" Input Current	V <sub>IN</sub> = 2.7V	I <sub>IHI</sub>	-	1.0	40	μA
"0" Input Voltage		V <sub>ILI</sub>	-	-	0.7	V
"1" Input Voltage		V <sub>IHI</sub>	2	-	-	V
Delay from TX inhibit, (0→1) to inhibited output	Note 1	t <sub>DXOFF</sub>	-	400	500	nS
Delay from TX inhibit, (1→0) to active output	Note 1	t <sub>DXON</sub>	-	400	500	nS
Differential output noise, inhibit mode		V <sub>NOI</sub>	-	0.8	10	mV p-p
Differential output impedance (inhibited)	Note 2	Z <sub>OI</sub>	2K	-	-	Ω

### Output Characteristics

Differential output level at point B-B' Fig 5, V <sub>cont</sub> = 10 Vdc, See Fig 3 for control voltage versus output level	R <sub>L</sub> = 140 Ω	V <sub>O</sub>	28	30	36	V p-p
Rise and fall times (10% to 90% of p-p output)		t <sub>R</sub>	200	250	300	nS
Output offset at point A-A' on Fig 5, 2.5 μS after midpoint crossing of the parity bit of the last word of a 660 μS message	R <sub>L</sub> = 35 Ω	V <sub>OS</sub>	-	-	±90	mV peak
Delay from 50% point of TX DATA or TX DATA $\bar$ input to zero crossing of differential signal. (Note 1)	ARX4418	t <sub>DTX</sub>	-	330	450	nS
	ARX4417		-	-	360	nS

## Electrical Characteristics, Receiver Section

Parameter	Condition	Symbol	Min	Typ	Max	Unit
Differential Input Impedance	f = 1MHz	Z <sub>IN</sub>	20K	100K		W
Differential Input Voltage Range		V <sub>IDR</sub>			40	V p-p
Input Common Mode Voltage Range	Note 1	V <sub>ICR</sub>	10			V p-p
Common Mode Rejection Ratio Note 3	Note 1	CMRR	40			dB

### Strobe Characteristics (Logic "0" inhibits output)

"0" Input Current	V <sub>S</sub> = 0.4 V	I <sub>IL</sub>	-	-0.2	-0.4	mA
"1" Input Current	V <sub>S</sub> = 2.7V	I <sub>IH</sub>	-	-1.0	+40	μA
"0" Input Voltage		V <sub>IL</sub>	-	-	0.7	V
"1" Input Voltage		V <sub>IH</sub>	2.0	-	-	V
Strobe Delay (turn-on or turn-off)	Note 1	t <sub>SD</sub>	-	-	150	nS

### Threshold Characteristics (Sinewave input)

Internal Threshold Voltage (referred to the bus) pins 6 and 11 grounded	100KHz-1MHz	V <sub>TH</sub>	0.60	0.8	1.05	V p-p
External threshold control (pins 6 & 11 open, resistors from pin 5 and 12 to ground)	Max R = 10KΩ	R <sub>TH</sub> / V <sub>TH</sub>	-	4000	-	Ω / V p-p

### Output Characteristics, RX DATA and RX $\overline{\text{DATA}}$

"1" State	I <sub>OH</sub> = -0.4 mA	V <sub>OH</sub>	2.5	3.6	-	V
"0" State	I <sub>OL</sub> = 4 mA	V <sub>OL</sub>	-	0.35	0.5	V
Delay, (average) from differential input zero crossings to RX DATA and RX $\overline{\text{DATA}}$ output 50% points	Note 1	t <sub>DRX</sub>	-	300	450	nS

## Power Data

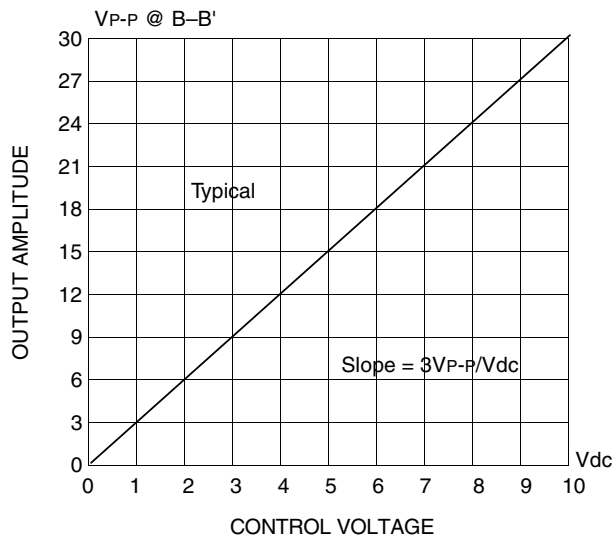
### Power Supply Currents (Power supplies set at +15V, -15V, +5V)

Duty Cycle	+V	-V	5V
Transmitter Standby	60mA	75mA	35mA
25% duty cycle Note 1	80mA	95mA	
50% duty cycle	105mA	120mA	
100% duty cycle Note 1	160mA	180mA	

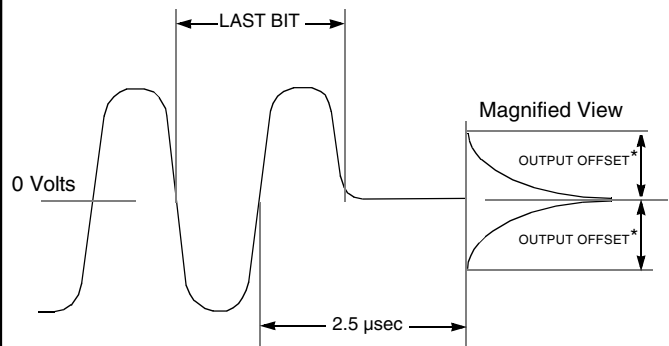
### Recommended Power Supply Voltage Range

+V	+11.4 Volts to +15.75 Volts
-V	-11.4 Volts to -15.75 Volts
Logic	+4.5 Volts to + 5.5 Volts

**Figure 3 – Transmitter (TX) Output Amplitude vs Control Voltage**

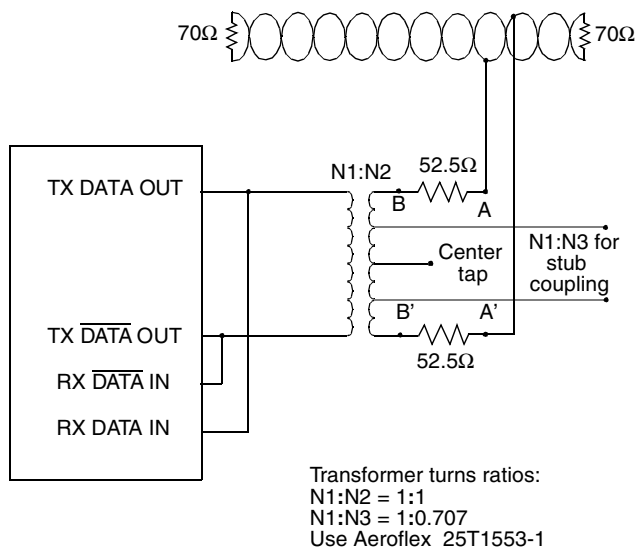


**Figure 4 – Transmitter (TX) Output offset**

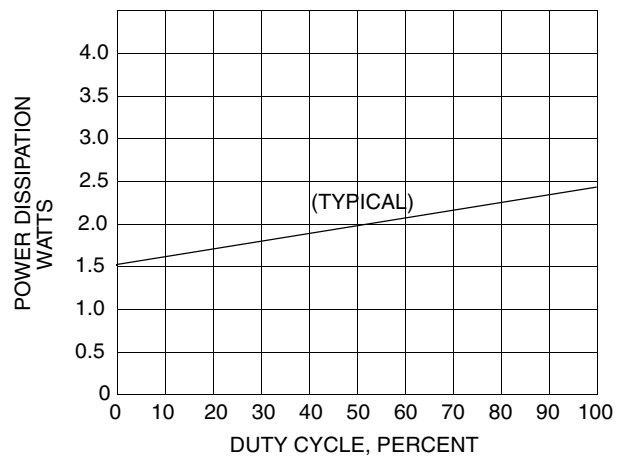


\*Offset measured at point A-A' in Fig 5

**Figure 5 – Typical Transformer Connection**



**Figure 6 – Power Dissipation vs Duty Cycle**

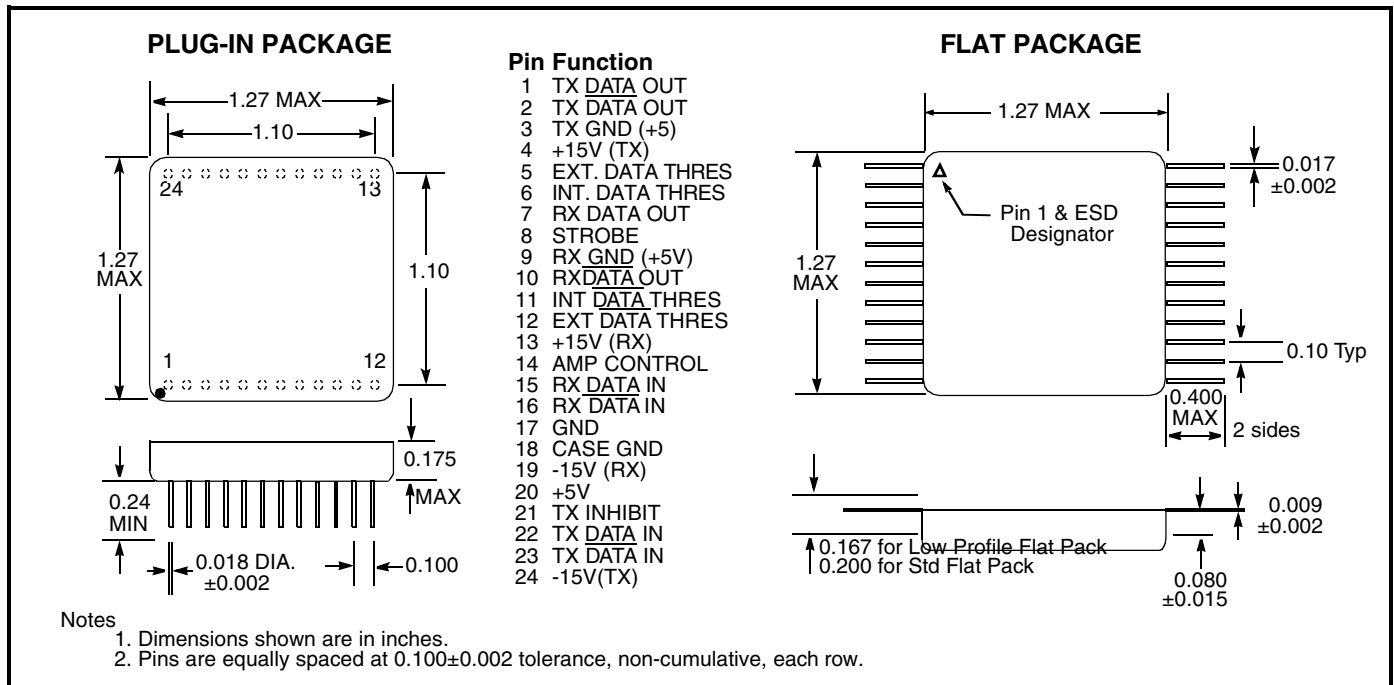


**NOTES**

1. Characteristics guaranteed by design, not production tested.
2. Power on or off, measured from 75KHz to 1MHz at point A-A' and transformer self impedance of 3KΩ minimum at 1MHz.
3. Specifications apply over the temperature range of -55°C to +125°C (Case Temperature) unless otherwise noted.
4. All typical values are measured at +25°C.

The information contained in this data sheet is believed to be accurate; however, Aeroflex Circuit Technology, assumes no responsibility for its use, and no license or rights are granted by implication or otherwise in connection therewith.

# AEROFLEX CIRCUIT TECHNOLOGY



## Configurations and Ordering Information

Model No.	DESC No.	Receiver Data level	Case	Specs.
ARX 4418	5962-9208503HXX	Normally Low	Plug In	1553 & Macair
ARX 4418-FP	5962-9208503HYX	Normally Low	Flat Pack	1553 & Macair
ARX 4418-LPFP	5962-TBD	Normally Low	Low Profile Flat Pack	1553 & Macair
ARX 4417	5962-TBD	Normally High	Plug In	1553
ARX 4417-FP	5962-TBD	Normally High	Flat Pack	1553
ARX 4417-LPFP	5962-TBD	Normally High	Low Profile Flat Pack	1553

Specifications subject to change without notice.

**Aeroflex Circuit Technology**  
**35 South Service Road**  
**Plainview New York 11803**

**Telephone: (516) 694-6700**  
**FAX: (516) 694-6715**  
**Toll Free Inquiries: 1-(800)THE-1553**