

## General Description

The AS5035 is a contactless magnetic incremental encoder with 64 quadrature pulses per revolution (8-bit resolution) and index output.

Only a simple two-pole magnet, rotating over the center of the chip is required. The magnet may be placed above or below the IC.

The angular position of the magnet during assembly is not critical as the AS5035 allows for a user programmable zero-position to an accuracy of 0.35°

Two diagnostic outputs are provided to indicate an out-of-range condition of the magnetic field as well as movement of the magnet in Z-axis. In addition, a specific combination of output states indicate a loss of power supply.

The AS5035 is available in a small 16pin SSOP package. It can be operated at either 3.3V or 5V supplies.

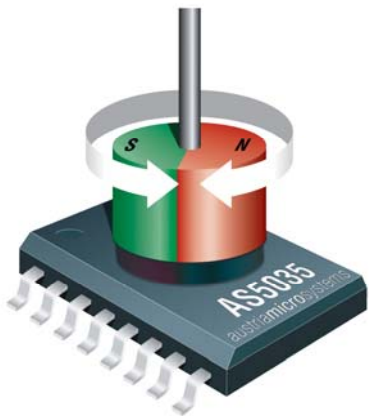

Typical arrangement of AS5035 and magnet

## Benefits

- Complete system-on-chip, including analog front end and digital signal processing
- 2-channel quadrature and index outputs provide an alternative to optical encoders
- User programmable Zero positioning by OTP allows easy assembly of magnet
- Diagnostic features for operation safety
- Ideal for applications in harsh environments due to magnetic sensing principle
- Robust system, tolerant to magnet misalignment, air gap variations, temperature variations and external magnetic stray fields

## Key Features

- Full turn (360°) contactless angular position encoder
- 2 quadrature A/B outputs with 64 pulses per revolution (ppr), 256 edges per revolution, 1.4° per step
- Accurate user programmable zero position
- Index output (one pulse per revolution)
- Failure detection mode for magnet placement monitoring and loss of power supply
- Wide temperature range: - 40°C to + 125°C
- Small lead-free package: SSOP 16 (5.3mm x 6.2mm)

## Applications

- Industrial applications:
  - Robotics
  - Replacement of optical encoders
  - Flow meters
  - Man-machine interface
- Automotive applications:
  - Power seat position sensing
  - Power mirror position sensing

## Pin Configuration

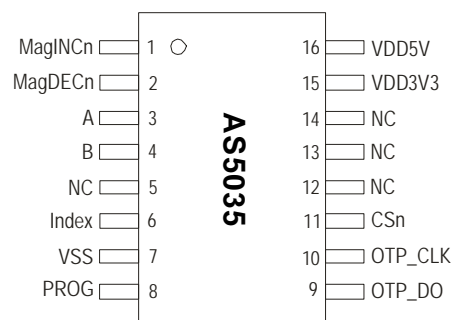

AS5035 Pin configuration SSOP16

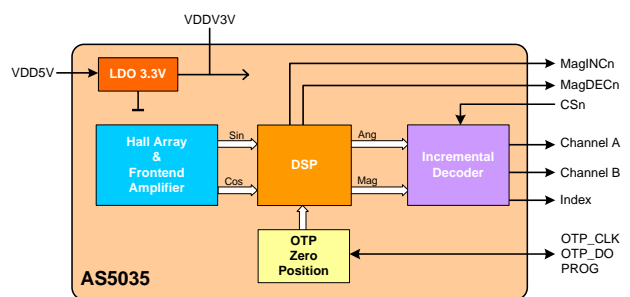

AS5035 Block diagram