

**Digital Attenuator
32.0 dB, 2-Bit, TTL Driver, DC-2.0 GHz**

**AT-273-PIN
V8**

Features

- Attenuation: 16.0 dB Steps to 32 dB
- Low DC Power Consumption
- Hermetic Surface Mount Package
- Integral TTL Driver
- 50 ohm Impedance
- Temperature Stability: ± 0.18 dB from -55°C to $+85^{\circ}\text{C}$ Typ.
- Tape and Reel Packaging Available
- Lead-Free CR-11 Package
- 260°C Reflow Compatible

Description

M/A-COM's AT-273-PIN is a GaAs FET digital attenuator with a 16.0 dB minimum step size and a 32 dB total attenuation range. This attenuator and integral TTL driver is in a hermetically sealed ceramic 16-lead surface mount package. The AT-273-PIN is ideally suited for use where accuracy, fast switching, very low power consumption and low intermodulation products are required. Typical applications include dynamic range setting in precision receiver circuits and other gain/leveling control circuits. Environmental screening is available. Contact the factory for information.

Functional Schematic¹

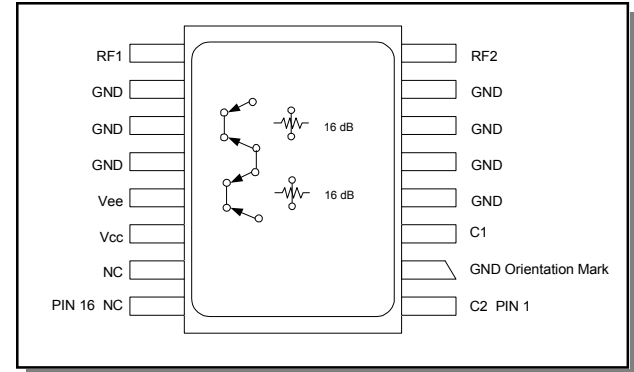

1. Use the C1 control for a single 16-dB bit.

Pin Configuration

Pin No.	Function	Pin No.	Function
1	C2	9	RF1
2	GND	10	GND
3	C1	11	GND
4	GND	12	GND
5	GND	13	Vee
6	GND	14	Vcc
7	GND	15	NC
8	RF2	16	NC

The metal bottom of the case must be connected to RF and DC ground.

Ordering Information

Part Number	Package
AT-273-PIN	Bulk Packaging

Note: Reference Application Note M513 for reel size information.

Note: Die quantity varies.

* Restrictions on Hazardous Substances, European Union Directive 2002/95/EC.

**Digital Attenuator
32.0 dB, 2-Bit, TTL Driver, DC-2.0 GHz**

**AT-273-PIN
V8**

Electrical Specifications: $T_A = 25^\circ\text{C}^{1,2}$

Parameter	Test Conditions	Frequency	Units	Min	Typ	Max
Insertion Loss	—	DC - 0.5 GHz	dB	—	—	1.6
		DC - 1.0 GHz	dB	—	—	1.7
		DC - 2.0 GHz	dB	—	—	1.9
Attenuation Accuracy	C1 Bit Full Attenuation (32 dB) Full Attenuation (32 dB) Full Attenuation (32 dB)	DC - 2.0 GHz	± 3% of attenuation setting in dB			
		DC - 0.5 GHz	± 3% of attenuation setting in dB			
		DC - 1.0 GHz	± 3% of attenuation setting in dB, -1 dB			
		DC - 2.0 GHz	± 3% of attenuation setting in dB, -3 dB			
VSWR	Full Range	DC - 2.0 GHz	Ratio	—	—	1.6:1
Trise, Tfall	10% to 90%	—	ns	—	7	—
Ton, Toff	50% Cntl to 90% / 10% RF	—	ns	—	28	—
Transients	In-Band (peak-to-peak)	—	mV	—	30	—
1 dB Compression	Input Power Input Power	0.05 GHz	dBm	—	+20	—
		0.5 - 2.0 GHz	dBm	—	+28	—
Input IP3	Two-tone inputs up to +5 dBm	0.05 GHz	dBm	—	+38	—
		0.5 - 2.0 GHz	dBm	—	+48	—
Input IP2	Two-tone inputs up to +5 dBm	0.05 GHz	dBm	—	+44	—
		0.5 - 2.0 GHz	dBm	—	+68	—
Vcc	—	—	V	4.5	5.0	5.5
-Vee	—	—	V	-8.0	—	-5.0
Vctl	Logic (0) TTL	—	V	0.0	—	0.8
Vctl	Logic (1) TTL	—	V	2.0	—	5.0
Input Leakage Current (Low) Input Leakage Current (High)	0 to 0.8V 2.0 to 5.0V	—	µA	—	—	1.0
		—	µA	—	—	1.0
Icc	Vcc = 4.5 to 5.5V Vctl = 0 to 0.8V, or Vcc -2.1V to Vcc	—	mA	—	—	2.0
-lee	Vee = -5.0 to -8.0V	—	mA	—	—	-1

1. All specifications apply when operated with bias voltages of +5V for Vcc and -5.0V for Vee.
2. This attenuator is guaranteed monotonic.

Digital Attenuator
32.0 dB, 2-Bit, TTL Driver, DC-2.0 GHz

**AT-273-PIN
V8**

Absolute Maximum Ratings ^{3,4}

Parameter	Absolute Maximum
Max. Input Power 0.05 GHz 0.5 - 2.0 GHz	+27 dBm +34 dBm
+Vcc	+5.5V
-Vee	-8.5V
Control Voltage ⁵	-0.5 to Vcc + 0.5V
Operating Temperature	-55°C to +125°C
Storage Temperature	-65°C to +150°C

- Exceeding any one or combination of these limits may cause permanent damage to this device.
- M/A-COM does not recommend sustained operation near these survivability limits.
- Standard CMOS TTL interface, latch-up will occur if logic signal is applied prior to power supply.

Handling Procedures

Please observe the following precautions to avoid damage:

Static Sensitivity

Gallium Arsenide Integrated Circuits are sensitive to electrostatic discharge (ESD) and can be damaged by static electricity. Proper ESD control techniques should be used when handling these devices.

Truth Table (Digital Attenuator)

C1	C2	Attenuation
0	0	Loss, Reference
0	1	16.0 dB
1	1	32.0 dB

0 = TTL Low; 1 = TTL High

Typical Performance Curves

Ref. Insertion Loss vs. Frequency

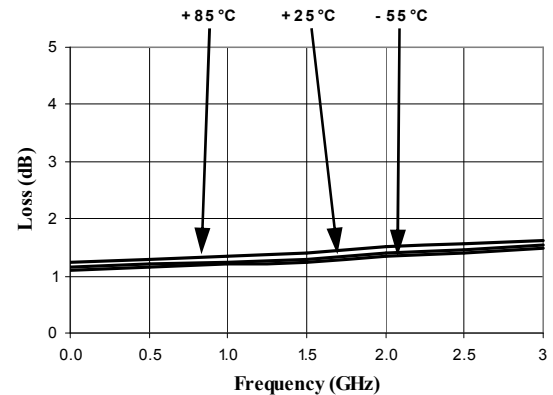

Attenuation Accuracy vs. Frequency

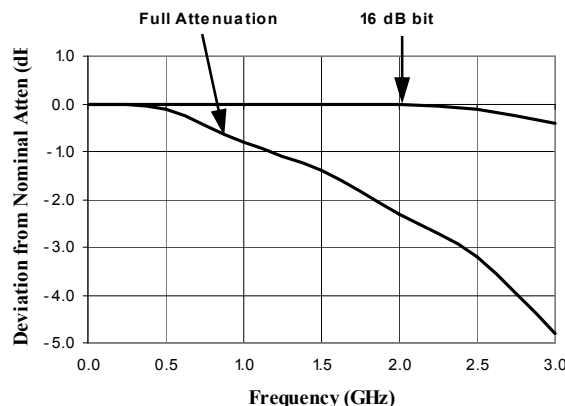

VSWR vs. Frequency

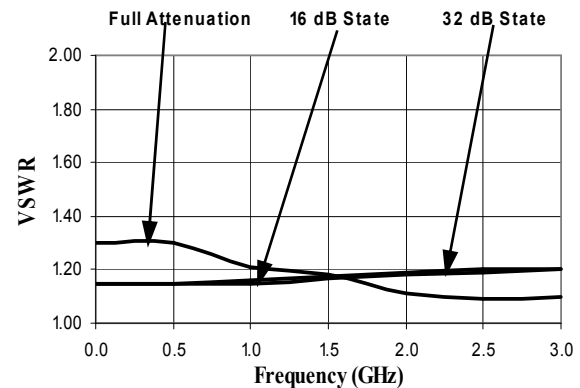

**Digital Attenuator
32.0 dB, 2-Bit, TTL Driver, DC-2.0 GHz**

**AT-273-PIN
V8**

Lead-Free CR-11 Ceramic Package[†]

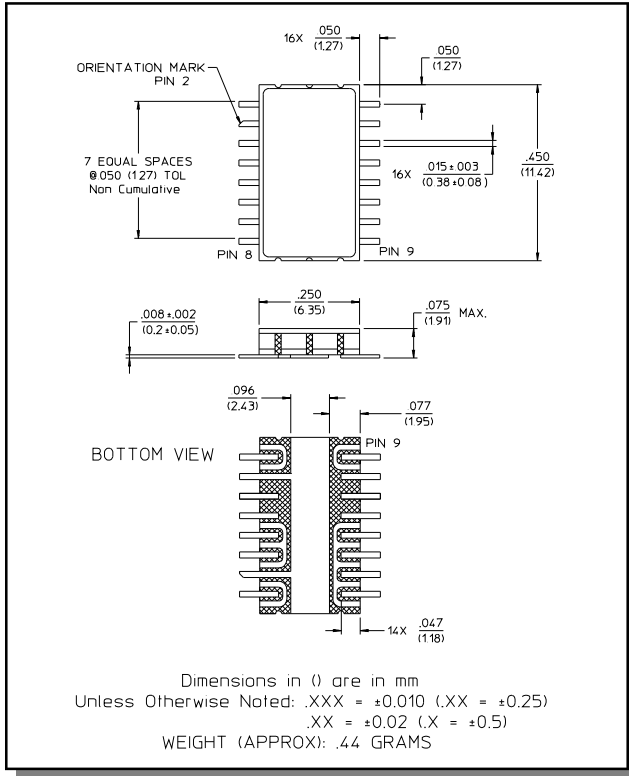

[†] Reference Application Note M538 for lead-free solder reflow recommendations.