

Features

- Programmable 16,777,216 x 1-bit Serial Memories Designed to Store Configuration Programs for Field Programmable Gate Arrays (FPGAs)
- 3.3V Output Capability
- 5V Tolerant I/O Pins
- Program Support using the Atmel ATDH2200E System or Industry Third Party Programmers
- In-System Programmable (ISP) via 2-wire Bus
- Simple Interface to SRAM FPGAs
- Compatible with Atmel AT40K and AT94K Devices, Altera FLEX[®], APEX[™] Devices, Lucent ORCA[®] FPGAs, Xilinx XC3000[™], XC4000[™], XC5200[™], Spartan[®], Virtex[®] FPGAs, Motorola MPA1000 FPGAs
- Cascadable Read-back to Support Additional Configurations or Higher-density Arrays
- Low-power CMOS FLASH Process
- Available in 6 mm x 6 mm x 1 mm 8-lead LAP (Pin-compatible with 8-lead SOIC/VOIC Footprint Packages), 20-lead PLCC, 44-lead PLCC and 44-lead TQFP Packages
- Emulation of Atmel's AT24CXXX Serial EEPROMs
- Low-power Standby Mode
- Single Device Capable of Holding 4 Bit Stream Files Allowing Simple System Reconfiguration
- Fast Serial Download Speeds up to 33 MHz
- Endurance: 10,000 Write Cycles Typical

Description

The AT17F Series of In-System Programmable Configuration PROMs (Configurators) provide an easy-to-use, cost-effective configuration memory for Field Programmable Gate Arrays. The AT17F Series device is packaged in the 8-lead LAP, 20-lead PLCC, 44-lead PLCC and 44-lead TQFP, see Table 1. The AT17F Series Configurator uses a simple serial-access procedure to configure one or more FPGA devices.

The AT17F Series Configurators can be programmed with industry-standard programmers, Atmel's ATDH2200E Programming Kit or Atmel's ATDH2225 ISP Cable.

Table 1. AT17F Series Packages

Package	AT17F16
8-lead LAP	Yes
20-lead PLCC	Yes
44-lead PLCC	Yes
44-lead TQFP	Yes



FPGA Configuration Flash Memory

AT17F16

Advance Information



Pin Configuration

8-lead LAP

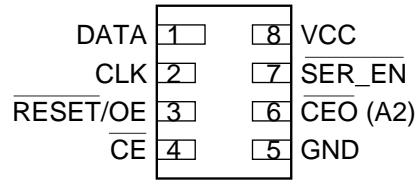

20-lead PLCC

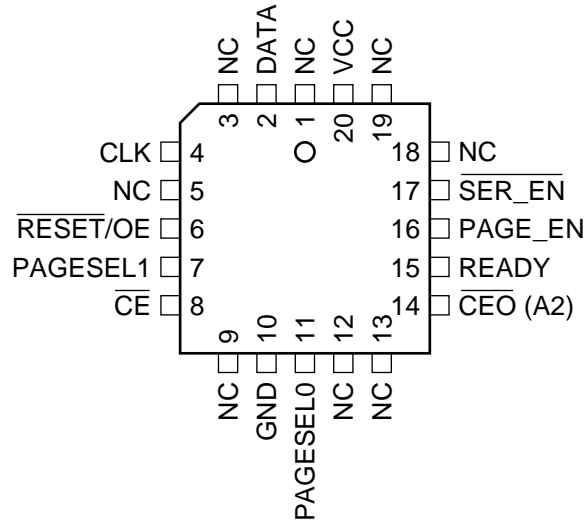

44 PLCC

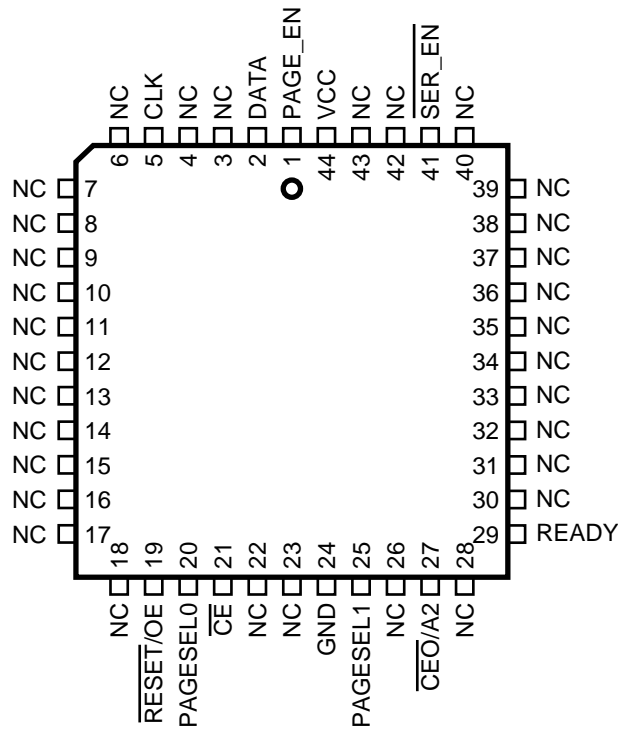

44 TQFP

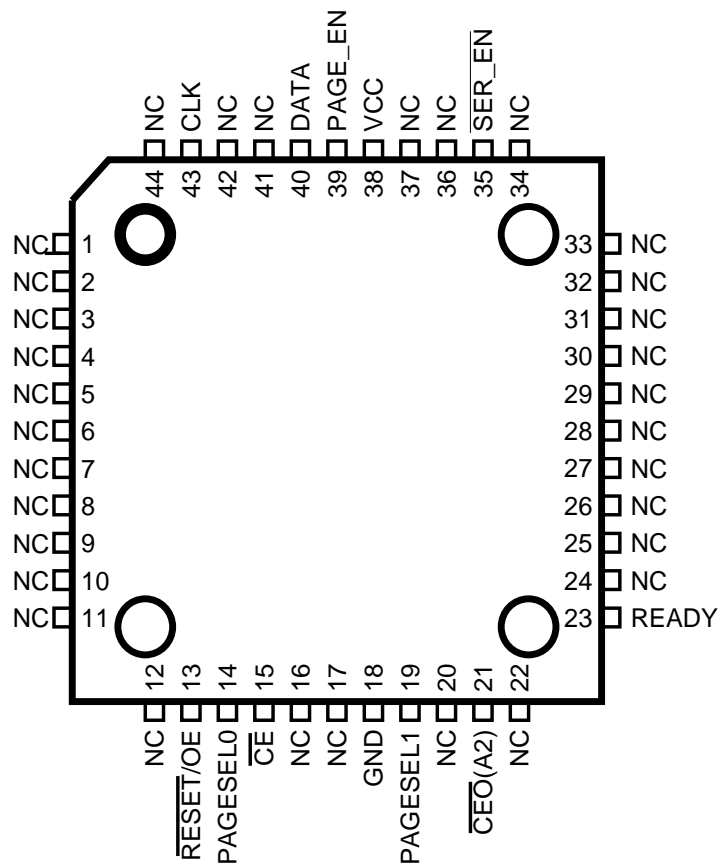

Block Diagram

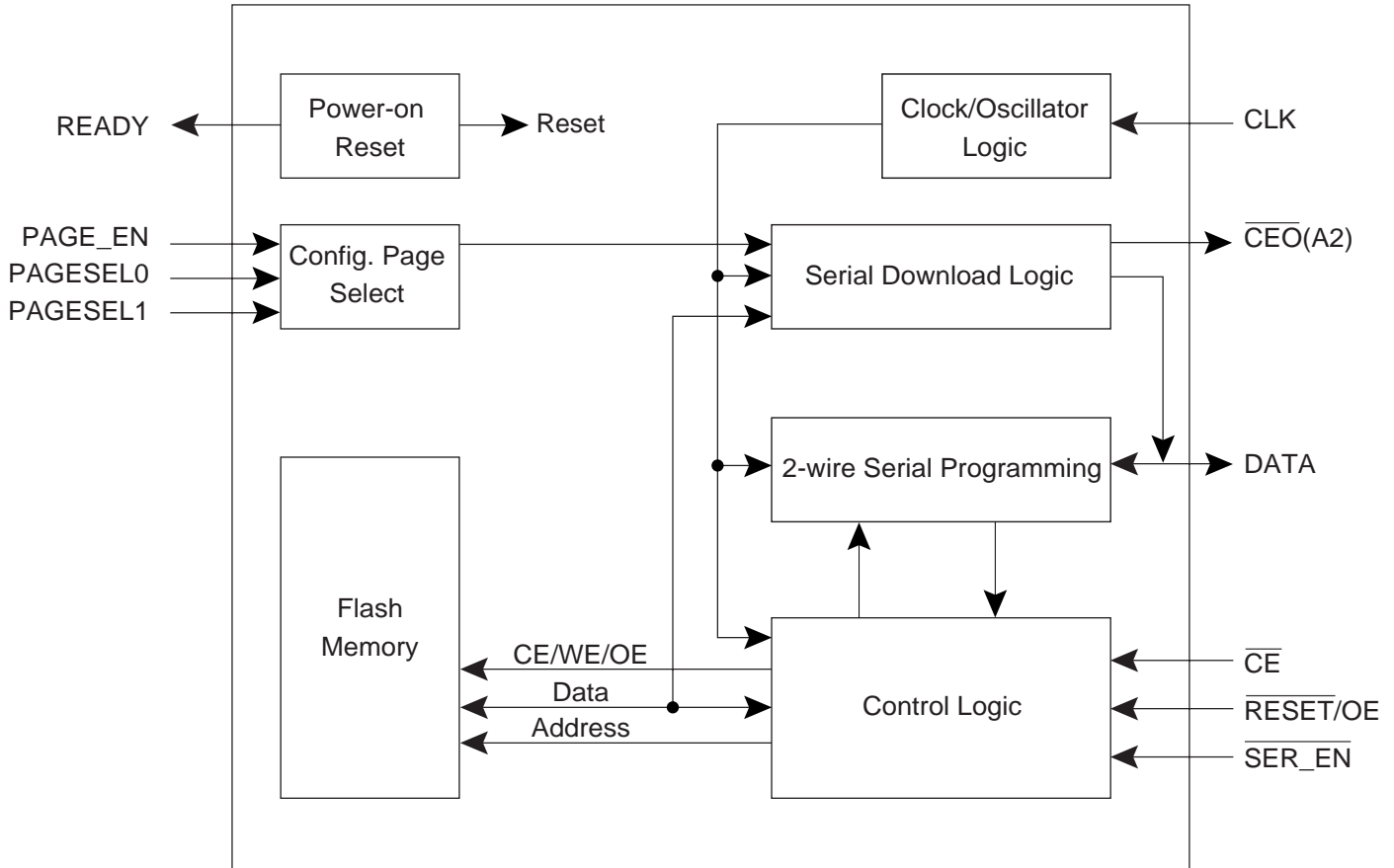

Device Description

The control signals for the configuration memory device (\overline{CE} , $\overline{RESET/OE}$ and CLK) interface directly with the FPGA device control signals. All FPGA devices can control the entire configuration process and retrieve data from the configuration device without requiring an external intelligent controller.

The $\overline{RESET/OE}$ and \overline{CE} pins control the tri-state buffer on the DATA output pin and enable the address counter. When $\overline{RESET/OE}$ is driven Low, the configuration device resets its address counter and tri-states its DATA pin. The \overline{CE} pin also controls the output of the AT17F Series Configurator. If \overline{CE} is held High after the $\overline{RESET/OE}$ reset pulse, the counter is disabled and the DATA output pin is tri-stated. When OE is subsequently driven High, the counter and the DATA output pin are enabled. When $\overline{RESET/OE}$ is driven Low again, the address counter is reset and the DATA output pin is tri-stated, regardless of the state of \overline{CE} .

When the configurator has driven out all of its data and \overline{CEO} is driven Low, the device tri-states the DATA pin to avoid contention with other configurators. Upon power-up, the address counter is automatically reset.

Pin Description

Name	I/O	AT17F16			
		8 LAP	20 PLCC	44 PLCC	44 TQFP
DATA	I/O	1	2	2	40
CLK	I	2	4	5	43
PAGE_EN	I	–	16	1	39
PAGESEL0	I	–	11	20	14
PAGESEL1	I	–	7	25	19
$\overline{\text{RESET/OE}}$	I	3	6	19	13
$\overline{\text{CE}}$	I	4	8	21	15
GND	–	5	10	24	18
$\overline{\text{CEO}}$	O	6	14	27	21
A2	I				
READY	O	–	15	29	23
$\overline{\text{SER_EN}}$	I	7	17	41	35
V _{CC}	–	8	20	44	38

DATA⁽¹⁾

Three-state DATA output for configuration. Open-collector bi-directional pin for programming.

CLK⁽¹⁾

Clock input. Used to increment the internal address and bit counter for reading and programming.

PAGE_EN⁽²⁾

Input used to enable page download mode. When PAGE_EN is high the configuration download address space is partitioned into 4 equal pages. This gives users the ability to easily store and retrieve multiple configuration bitstreams from a single configuration device. This input works in conjunction with the PAGESEL inputs. PAGE_EN must be remain low if paging is not desired. When SER_EN is Low (ISP mode) this pin has no effect.

- Notes: 1. This pin has an internal 20 KΩ pull-up resistor.
 2. This pin has an internal 30 KΩ pull-down resistor.



PAGESEL[1:0]⁽²⁾

Page select inputs. Used to determine which of the 4 memory pages are targeted during a serial configuration download. The address space for each of the pages is shown in Table 2. When SER_EN is Low (ISP mode) these pins have no effect.

Table 2. Address Space

Paging Decodes	AT17F16 (16 Mbits)
PAGESEL = 00, PAGE_EN = 1	00000 – 3FFFFh
PAGESEL = 01, PAGE_EN = 1	40000 – 7FFFFh
PAGESEL = 10, PAGE_EN = 1	80000 – BFFFFh
PAGESEL = 11, PAGE_EN = 1	C0000 – FFFFFh
PAGESEL = XX, PAGE_EN = 0	00000 – FFFFFh

RESET/OE⁽¹⁾

Output Enable (active High) and RESET (active Low) when SER_EN is High. A Low level on RESET/OE resets both the address and bit counters. A High level (with CE Low) enables the data output driver.

CE⁽¹⁾

Chip Enable input (active Low). A Low level (with OE High) allows CLK to increment the address counter and enables the data output driver. A High level on CE disables both the address and bit counters and forces the device into a low-power standby mode. Note that this pin will *not* enable/disable the device in the 2-wire Serial Programming mode (SER_EN Low).

GND

Ground pin. A 0.2 μF decoupling capacitor between V_{CC} and GND is recommended.

CEO

Chip Enable Output (when SER_EN is High). This output goes Low when the internal address counter has reached its maximum value. If the PAGE_EN input is set High, the maximum value is the highest address in the selected partition. The PAGESEL[1:0] inputs are used to make the 4 partition selections. If the PAGE_EN input is set Low, the device is not partitioned and the address maximum value is the highest address in the device, see Table 2 on page 6. In a daisy chain of AT17F Series devices, the CEO pin of one device must be connected to the CE input of the next device in the chain. It will stay Low as long as CE is Low and OE is High. It will then follow CE until OE goes Low; thereafter, CEO will stay High until the entire EEPROM is read again.

A2⁽¹⁾

Device selection input, (when SER_EN Low). The input is used to enable (or chip select) the device during programming (i.e., when SER_EN is Low). Refer to the AT17F Programming Specification available on the Atmel web site for additional details.

READY

Open collector reset state indicator. Driven Low during power-up reset, released when power-up is complete. (recommended 4.7 kΩ pull-up on this pin if used).

SER_EN⁽¹⁾

The serial enable input must remain High during FPGA configuration operations. Bringing SER_EN Low enables the 2-Wire Serial Programming Mode. For non-ISP applications, SER_EN should be tied to V_{CC}.

V_{CC}

+3.3V (±10%).

- Notes:
1. This pin has an internal 20 KΩ pull-up resistor.
 2. This pin has an internal 30 KΩ pull-down resistor.

FPGA Master Serial Mode Summary

The I/O and logic functions of any SRAM-based FPGA are established by a configuration program. The program is loaded either automatically upon power-up, or on command, depending on the state of the FPGA mode pins. In Master mode, the FPGA automatically loads the configuration program from an external memory. The AT17F Serial Configuration PROM has been designed for compatibility with the Master Serial mode.

This document discusses the Atmel AT40K, AT40KAL and AT94KAL applications as well as Xilinx applications.

Control of Configuration

Most connections between the FPGA device and the AT17F Serial Configurator PROM are simple and self-explanatory.

- The DATA output of the AT17F Series Configurator drives DIN of the FPGA devices.
- The master FPGA CCLK output drives the CLK input of the AT17F Series Configurator.
- The $\overline{\text{CEO}}$ output of any AT17F Series Configurator drives the $\overline{\text{CE}}$ input of the next Configurator in a cascade chain of configurator devices.
- $\overline{\text{SER_EN}}$ must be connected to V_{CC} or allowed to float to logic High via the internal pull-up resistor (except during ISP).
- The READY pin is available as an open-collector indicator of the device's reset status; it is driven Low while the device is in its power-on reset cycle and released (tri-stated) when the cycle is complete.
- PAGE_EN must be held Low if download paging is not desired. The PAGESEL[1:0] inputs must be tied off High or Low. If paging is desired, PAGE_EN must be High and the PAGESEL pins must be set to High or Low such that the desired page is selected, see Table 2 on page 6.

Cascading Serial Configuration Devices

For multiple FPGAs configured as a daisy-chain, or for FPGAs requiring larger configuration memories, cascaded configurators provide additional memory.

After the last bit from the first configurator is read, the clock signal to the configurator asserts its $\overline{\text{CEO}}$ output Low and disables its DATA line driver. The second configurator recognizes the Low level on its $\overline{\text{CE}}$ input and enables its DATA output.

After configuration is complete, the address counters of all cascaded configurators are reset if the $\overline{\text{RESET/OE}}$ on each configurator is driven to its active (Low) level.

If the address counters are not to be reset upon completion, then the $\overline{\text{RESET/OE}}$ input can be tied to its inactive (High) level.

Programming Mode

The programming mode is entered by bringing $\overline{\text{SER_EN}}$ Low. In this mode the chip can be programmed by the 2-wire serial bus. The programming is done at V_{CC} supply only. Programming super voltages are generated inside the chip. The AT17F parts are read/write at 3.3V nominal. Refer to the AT17F Programming Specification available on the Atmel web site (www.atmel.com) for more programming details. AT17F devices are supported by the Atmel ATDH2200E programming system along with many third party programmers.

Standby Mode

The AT17F Series Configurators enter a low-power standby mode whenever $\overline{\text{SER_EN}}$ is High and $\overline{\text{CE}}$ is asserted High. In this mode, the AT17F Configurator consumes less than 5 mA of current at 3.6V. The output remains in a high-impedance state regardless of the state of the OE input.

Absolute Maximum Ratings*

Operating Temperature.....	-40°C to +85°C
Storage Temperature	-65°C to +150°C
Voltage on Any Pin with Respect to Ground	-0.1V to $V_{CC} + 0.5V$
Supply Voltage (V_{CC})	-0.5V to +4.0V
Maximum Soldering Temp. (10 sec. @ 1/16 in.).....	260°C
ESD ($R_{ZAP} = 1.5K$, $C_{ZAP} = 100$ pF).....	2000V

*NOTICE: Stresses beyond those listed under Absolute Maximum Ratings may cause permanent damage to the device. This is a stress rating only and functional operation of the device at these or any other conditions beyond those listed under operating conditions is not implied. Exposure to Absolute Maximum Rating conditions for extended periods of time may affect device reliability.

Operating Conditions

Symbol	Description	AT17F Series Configurator		Units	
		Min	Max		
V_{CC}	Commercial	Supply voltage relative to GND -0°C to +70°C	2.97	3.63	V
	Industrial	Supply voltage relative to GND -40°C to +85°C	2.97	3.63	V

DC Characteristics

Symbol	Description	AT17F16		Units
		Min	Max	
V_{IH}	High-level Input Voltage	2.0	V_{CC}	V
V_{IL}	Low-level Input Voltage	0	0.8	V
V_{OH}	High-level Output Voltage ($I_{OH} = -2.5$ mA)	2.4	0.4	V
V_{OL}	Low-level Output Voltage ($I_{OL} = +3$ mA)			Commercial
V_{OH}	High-level Output Voltage ($I_{OH} = -2$ mA)	2.4	0.4	V
V_{OL}	Low-level Output Voltage ($I_{OL} = +3$ mA)			Industrial
I_{CCA}	Supply Current, Active Mode (3.6V 33 MHz)		40	mA
I_L	Input or Output Leakage Current ($V_{IN} = V_{CC}$ or GND)	-10	10	μA
I_{CCS}	Supply Current, Standby Mode	Commercial	2	mA
		Industrial	2	mA

AC Characteristics

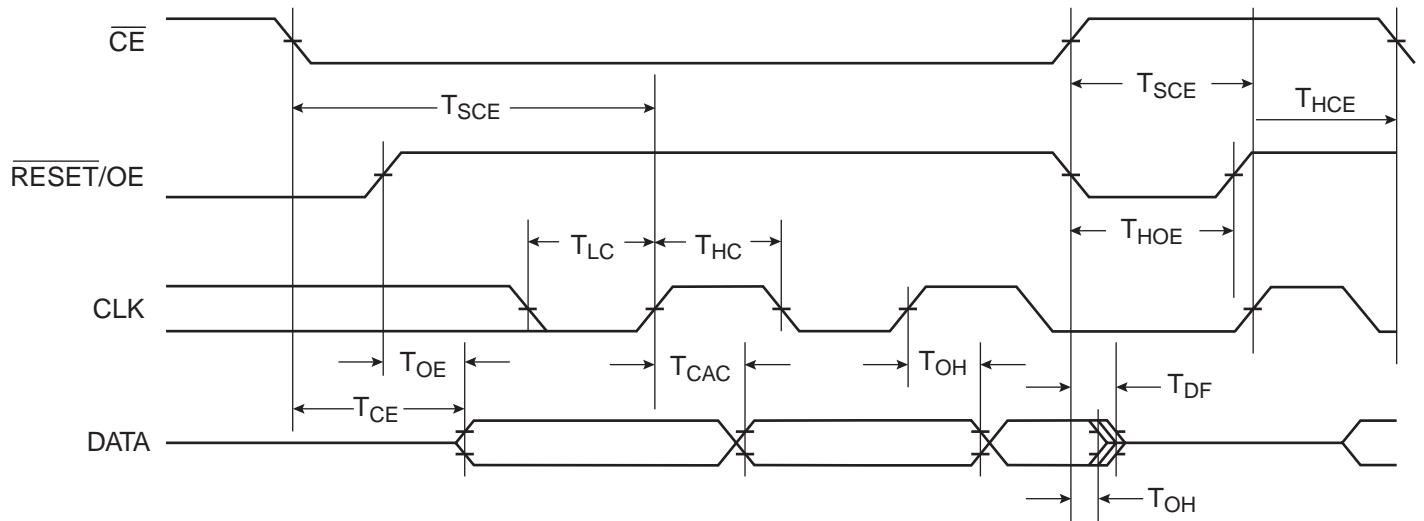

AC Characteristics when Cascading

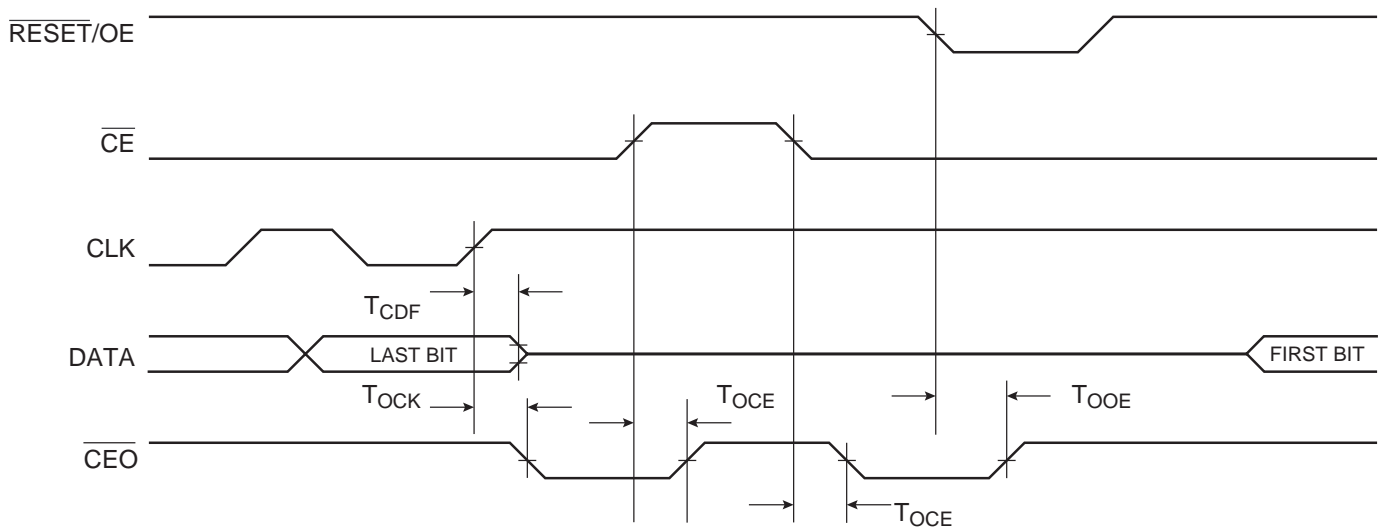

AC Characteristics

Symbol	Description	AT17F16		Units
		Min	Max	
T _{OE} ⁽²⁾	OE to Data Delay	Commercial	50	ns
		Industrial ⁽¹⁾	55	ns
T _{CE} ⁽²⁾	$\overline{\text{CE}}$ to Data Delay	Commercial	55	ns
		Industrial ⁽¹⁾	60	ns
T _{CAC} ⁽²⁾	CLK to Data Delay	Commercial	3	ns
		Industrial ⁽¹⁾	30	ns
T _{OH}	Data Hold from $\overline{\text{CE}}$, OE, or CLK	Commercial	0	ns
		Industrial ⁽¹⁾	0	ns
T _{DF} ⁽³⁾	$\overline{\text{CE}}$ or OE to Data Float Delay	Commercial	15	ns
		Industrial ⁽¹⁾	15	ns
T _{LC}	CLK Low Time	Commercial	15	ns
		Industrial ⁽¹⁾	15	ns
T _{HC}	CLK High Time	Commercial	15	ns
		Industrial ⁽¹⁾	15	ns
T _{SCE}	$\overline{\text{CE}}$ Setup Time to CLK (to guarantee proper counting)	Commercial	20	ns
		Industrial ⁽¹⁾	25	ns
T _{HCE}	$\overline{\text{CE}}$ Hold Time from CLK (to guarantee proper counting)	Commercial	0	ns
		Industrial ⁽¹⁾	0	ns
T _{HOE}	Reset/OE Low Time (guarantees counter is reset)	Commercial	20	ns
		Industrial ⁽¹⁾	20	ns
F _{MAX}	Maximum Input Clock Frequency SEREN = 0	Commercial	10	MHz
		Industrial ⁽¹⁾	10	MHz
F _{MAX}	Maximum Input Clock Frequency SEREN = 1	Commercial	33	MHz
		Industrial ⁽¹⁾	33	MHz
T _{WR}	Write Cycle Time ⁽⁴⁾	Commercial	30	μs
		Industrial ⁽¹⁾	30	μs
T _{EC}	Erase Cycle Time ⁽⁴⁾	Commercial	60	s
		Industrial ⁽¹⁾	60	s

- Notes:
1. Preliminary specifications for military operating range only.
 2. AC test lead = 50 pF.
 3. Float delays are measured with 5 pF AC loads. Transition is measured ± 200 mV from steady-state active levels.
 4. See the AT17F Programming Specification for procedural information.

AC Characteristics When Cascading

Symbol	Description	AT17F16		Units
		Min	Max	
T _{CDF} ⁽³⁾	CLK to Data Float Delay	Commercial	50	ns
		Industrial	50	ns
T _{OCK} ⁽²⁾	CLK to \overline{CEO} Delay	Commercial	50	ns
		Industrial	55	ns
T _{OCE} ⁽²⁾	\overline{CE} to \overline{CEO} Delay	Commercial	35	ns
		Industrial	40	ns
T _{OOE} ⁽²⁾	$\overline{RESET/OE}$ to \overline{CEO} Delay	Commercial	35	ns
		Industrial	35	ns
F _{MAX}	Maximum Input Clock Frequency	Commercial	33	MHz
		Industrial	33	MHz

- Notes:
1. AC test lead = 50 pF.
 2. Float delays are measured with 5 pF AC loads. Transition is measured ± 200 mV from steady-state active levels.

Thermal Resistance Coefficients

Package Type		AT17F16	
8CN4	Leadless Array Package (LAP)	θ_{JC} [$^{\circ}\text{C}/\text{W}$]	–
		θ_{JA} [$^{\circ}\text{C}/\text{W}$] ⁽¹⁾	–
20J	Plastic Leaded Chip Carrier (PLCC)	θ_{JC} [$^{\circ}\text{C}/\text{W}$]	–
		θ_{JA} [$^{\circ}\text{C}/\text{W}$] ⁽¹⁾	–
44A	Thin Plastic Quad Flat Package (TQFP)	θ_{JC} [$^{\circ}\text{C}/\text{W}$]	17
		θ_{JA} [$^{\circ}\text{C}/\text{W}$] ⁽¹⁾	62
44J	Plastic Leaded Chip Carrier (PLCC)	θ_{JC} [$^{\circ}\text{C}/\text{W}$]	15
		θ_{JA} [$^{\circ}\text{C}/\text{W}$] ⁽¹⁾	50

Note: 1. Airflow = 0 ft/min.

Ordering Information

Memory Size	Ordering Code	Package	Operation Range
16-Mbit	AT17F16-30CC	8CN4 - 8 LAP	Commercial (0°C to 70°C)
	AT17F16-30JC	20J - 20 PLCC	
	AT17F16-30TQC	44A - 44 TQFP	
	AT17F16-30BJC	44J - 44 PLCC	
	AT17F16-30CI	8CN4 - 8 LAP	Industrial (-40°C to 85°C)
	AT17F16-30JI	20J - 20 PLCC	
	AT17F16-30TQI	44A - 44 TQFP	
	AT17F16-30BJI	44J - 44 PLCC	

Package Type	
8CN4	8-lead, 6 mm x 6 mm x 1 mm, Leadless Array Package (LAP) – Pin-compatible with 8-lead SOIC/VOID Packages
20J	20-lead, Plastic J-leaded Chip Carrier (PLCC)
44A	44-lead, Thin (1.0 mm) Plastic Quad Flat Package Carrier (TQFP)
44J	44-lead, Plastic J-leaded Chip Carrier (PLCC)

Packaging Information

8CN4 – LAP

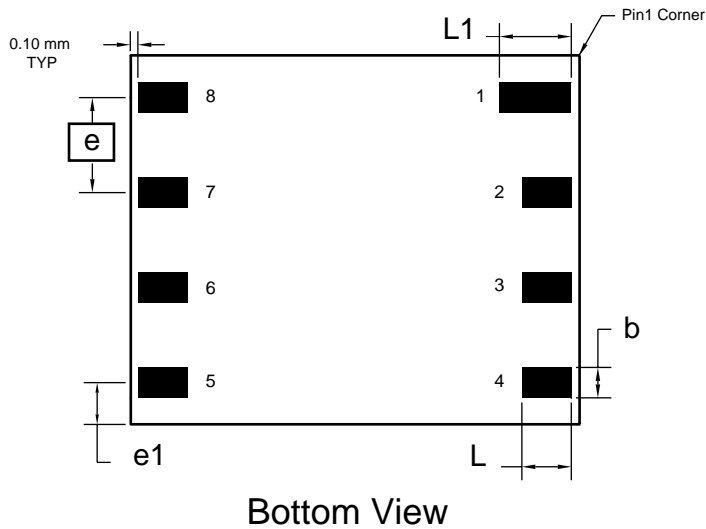
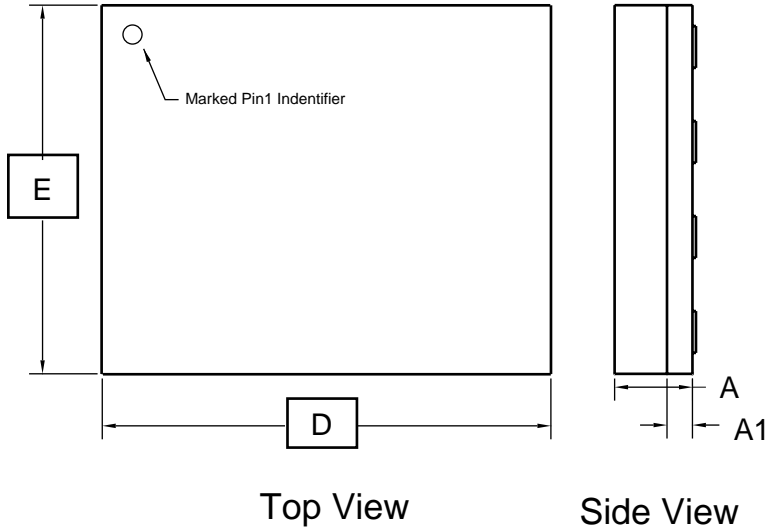

COMMON DIMENSIONS
(Unit of Measure = mm)

SYMBOL	MIN	NOM	MAX	NOTE
A	0.94	1.04	1.14	
A1	0.30	0.34	0.38	
b	0.45	0.50	0.55	1
D	5.89	5.99	6.09	
E	4.89	5.99	6.09	
e	1.27 BSC			
e1	1.10 REF			
L	0.95	1.00	1.05	1
L1	1.25	1.30	1.35	1

Note: 1. Metal Pad Dimensions.

11/14/01

2325 Orchard Parkway
San Jose, CA 95131

TITLE
8CN4, 8-lead (6 x 6 x 1.04 mm Body), Lead Pitch 1.27 mm,
Leadless Array Package (LAP)

DRAWING NO.	REV.
8CN4	A

20J – PLCC

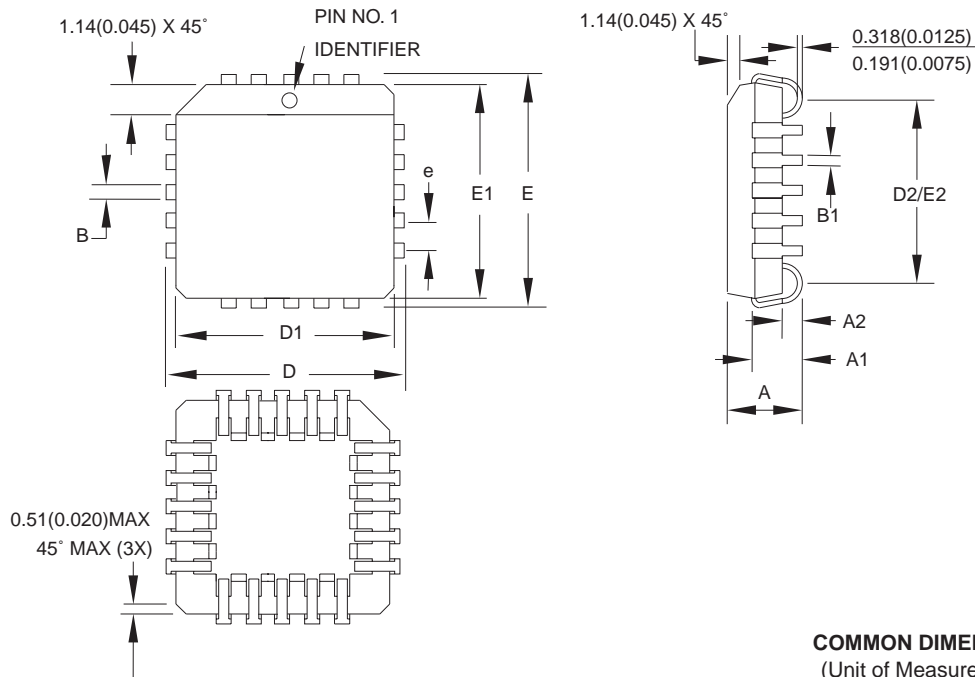

COMMON DIMENSIONS
(Unit of Measure = mm)

SYMBOL	MIN	NOM	MAX	NOTE
A	4.191	–	4.572	
A1	2.286	–	3.048	
A2	0.508	–	–	
D	9.779	–	10.033	
D1	8.890	–	9.042	Note 2
E	9.779	–	10.033	
E1	8.890	–	9.042	Note 2
D2/E2	7.366	–	8.382	
B	0.660	–	0.813	
B1	0.330	–	0.533	
e	1.270 TYP			

- Notes:
1. This package conforms to JEDEC reference MS-018, Variation AA.
 2. Dimensions D1 and E1 do not include mold protrusion. Allowable protrusion is .010" (0.254 mm) per side. Dimension D1 and E1 include mold mismatch and are measured at the extreme material condition at the upper or lower parting line.
 3. Lead coplanarity is 0.004" (0.102 mm) maximum.

10/04/01



2325 Orchard Parkway
San Jose, CA 95131

TITLE

20J, 20-lead, Plastic J-leded Chip Carrier (PLCC)

DRAWING NO.

20J

REV.

B



44A – TQFP

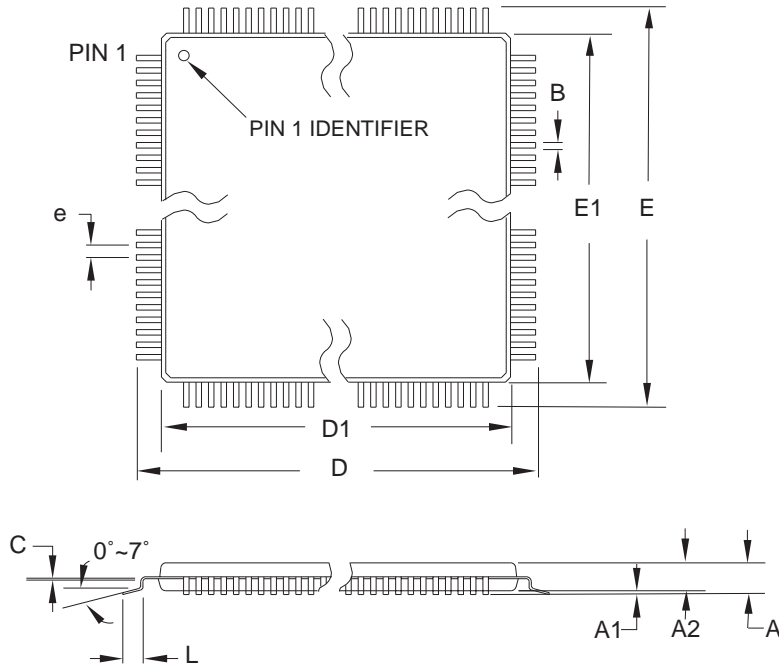

COMMON DIMENSIONS
(Unit of Measure = mm)

SYMBOL	MIN	NOM	MAX	NOTE
A	–	–	1.20	
A1	0.05	–	0.15	
A2	0.95	1.00	1.05	
D	11.75	12.00	12.25	
D1	9.90	10.00	10.10	Note 2
E	11.75	12.00	12.25	
E1	9.90	10.00	10.10	Note 2
B	0.30	–	0.45	
C	0.09	–	0.20	
L	0.45	–	0.75	
e	0.80 TYP			

- Notes:
1. This package conforms to JEDEC reference MS-026, Variation ACB.
 2. Dimensions D1 and E1 do not include mold protrusion. Allowable protrusion is 0.25 mm per side. Dimensions D1 and E1 are maximum plastic body size dimensions including mold mismatch.
 3. Lead coplanarity is 0.10 mm maximum.

10/5/2001

2325 Orchard Parkway San Jose, CA 95131	TITLE	DRAWING NO.	REV.
	44A , 44-lead, 10 x 10 mm Body Size, 1.0 mm Body Thickness, 0.8 mm Lead Pitch, Thin Profile Plastic Quad Flat Package (TQFP)	44A	B

44J – PLCC

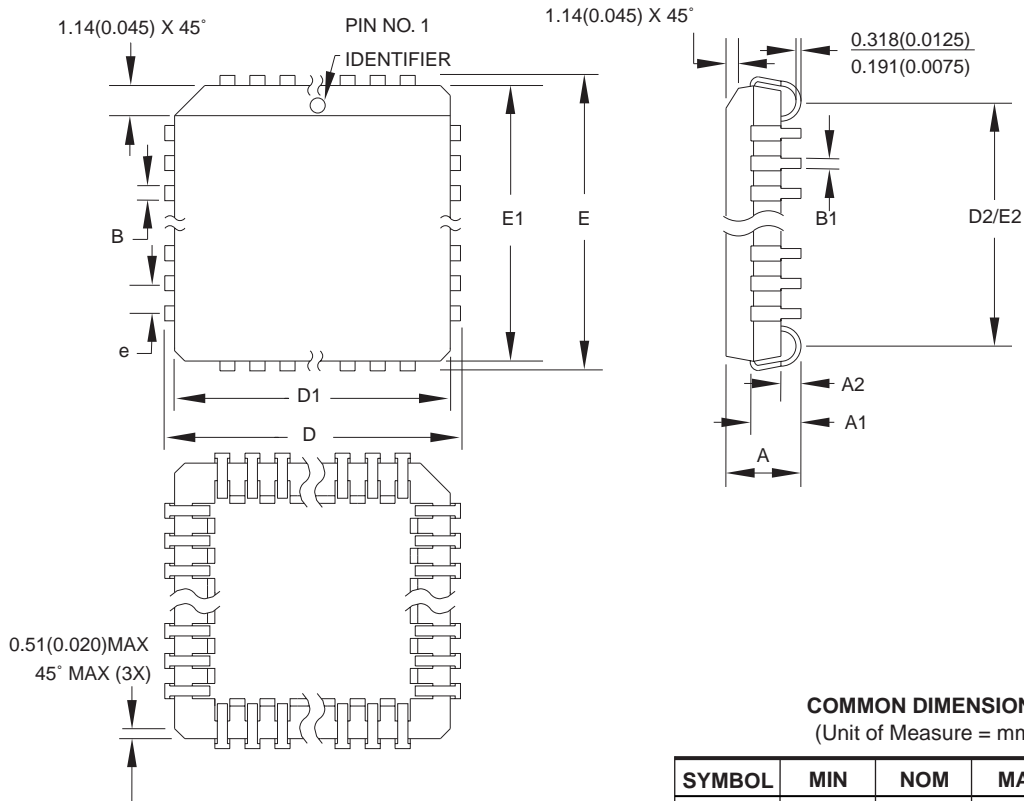

COMMON DIMENSIONS
(Unit of Measure = mm)

SYMBOL	MIN	NOM	MAX	NOTE
A	4.191	–	4.572	
A1	2.286	–	3.048	
A2	0.508	–	–	
D	17.399	–	17.653	
D1	16.510	–	16.662	Note 2
E	17.399	–	17.653	
E1	16.510	–	16.662	Note 2
D2/E2	14.986	–	16.002	
B	0.660	–	0.813	
B1	0.330	–	0.533	
e	1.270 TYP			

- Notes:
1. This package conforms to JEDEC reference MS-018, Variation AC.
 2. Dimensions D1 and E1 do not include mold protrusion. Allowable protrusion is .010" (0.254 mm) per side. Dimension D1 and E1 include mold mismatch and are measured at the extreme material condition at the upper or lower parting line.
 3. Lead coplanarity is 0.004" (0.102 mm) maximum.

10/04/01



2325 Orchard Parkway
San Jose, CA 95131

TITLE

44J, 44-lead, Plastic J-leaded Chip Carrier (PLCC)

DRAWING NO.

44J

REV.

B





Atmel Corporation

2325 Orchard Parkway
San Jose, CA 95131
Tel: 1(408) 441-0311
Fax: 1(408) 487-2600

Regional Headquarters

Europe

Atmel Sarl
Route des Arsenalux 41
Case Postale 80
CH-1705 Fribourg
Switzerland
Tel: (41) 26-426-5555
Fax: (41) 26-426-5500

Asia

Room 1219
Chinachem Golden Plaza
77 Mody Road Tsimshatsui
East Kowloon
Hong Kong
Tel: (852) 2721-9778
Fax: (852) 2722-1369

Japan

9F, Tonetsu Shinkawa Bldg.
1-24-8 Shinkawa
Chuo-ku, Tokyo 104-0033
Japan
Tel: (81) 3-3523-3551
Fax: (81) 3-3523-7581

Atmel Operations

Memory

2325 Orchard Parkway
San Jose, CA 95131
Tel: 1(408) 441-0311
Fax: 1(408) 436-4314

Microcontrollers

2325 Orchard Parkway
San Jose, CA 95131
Tel: 1(408) 441-0311
Fax: 1(408) 436-4314

La Chantrerie
BP 70602
44306 Nantes Cedex 3, France
Tel: (33) 2-40-18-18-18
Fax: (33) 2-40-18-19-60

ASIC/ASSP/Smart Cards

Zone Industrielle
13106 Rousset Cedex, France
Tel: (33) 4-42-53-60-00
Fax: (33) 4-42-53-60-01

1150 East Cheyenne Mtn. Blvd.
Colorado Springs, CO 80906
Tel: 1(719) 576-3300
Fax: 1(719) 540-1759

Scottish Enterprise Technology Park
Maxwell Building
East Kilbride G75 0QR, Scotland
Tel: (44) 1355-803-000
Fax: (44) 1355-242-743

RF/Automotive

Theresienstrasse 2
Postfach 3535
74025 Heilbronn, Germany
Tel: (49) 71-31-67-0
Fax: (49) 71-31-67-2340

1150 East Cheyenne Mtn. Blvd.
Colorado Springs, CO 80906
Tel: 1(719) 576-3300
Fax: 1(719) 540-1759

Biometrics/Imaging/Hi-Rel MPU/ High Speed Converters/RF Datacom

Avenue de Rochepleine
BP 123
38521 Saint-Egreve Cedex, France
Tel: (33) 4-76-58-30-00
Fax: (33) 4-76-58-34-80

Atmel Programmable SLI Hotline
(408) 436-4119

Atmel Programmable SLI e-mail
configurator@atmel.com

FAQ
Available on web site

e-mail
literature@atmel.com

Web Site
<http://www.atmel.com>

Disclaimer: Atmel Corporation makes no warranty for the use of its products, other than those expressly contained in the Company's standard warranty which is detailed in Atmel's Terms and Conditions located on the Company's web site. The Company assumes no responsibility for any errors which may appear in this document, reserves the right to change devices or specifications detailed herein at any time without notice, and does not make any commitment to update the information contained herein. No licenses to patents or other intellectual property of Atmel are granted by the Company in connection with the sale of Atmel products, expressly or by implication. Atmel's products are not authorized for use

© Atmel Corporation 2003. All rights reserved. Atmel® and combinations thereof, are the registered trademarks of Atmel Corporation or its subsidiaries. FLEX™ is the trademarks of Altera Corporation. ORCA™ is the trademark of Lucent Technologies, Inc. SPARTAN® and Virtex® are the registered trademarks, and XC3000™, XC4000™ and XC5200™ are the trademarks of Xilinx, Inc. APEX™ is the trademark of MIPS Technologies. Other terms and product names may be the trademarks of others.



Printed on recycled paper.