

ATS622LSB

TRUE ZERO-SPEED HALL-EFFECT GEAR-TOOTH SENSOR

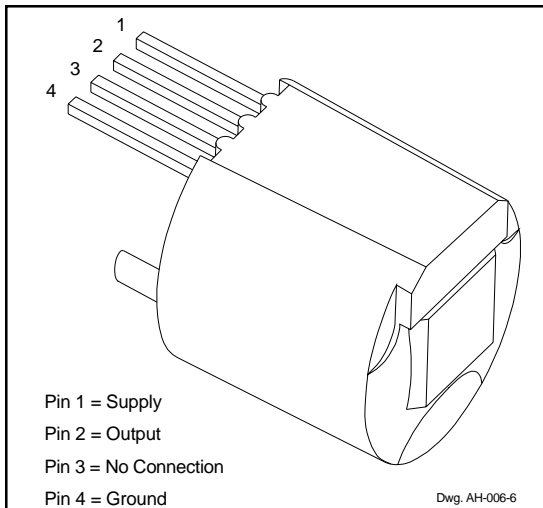

Pin 1 = Supply
Pin 2 = Output
Pin 3 = No Connection
Pin 4 = Ground

Dwg. AH-006-6

ABSOLUTE MAXIMUM RATINGS at $T_A = 25^\circ\text{C}$

Supply Voltage, V_{CC}	26.5 V*
Reverse Supply Voltage, V_{RCC}	-24 V
Continuous Output Current, I_{OUT}	20 mA
Reverse Output Current, I_{ROUT}	50 mA
Package Power Dissipation, P_D	See Graph
Operating Temperature Range, T_A	-40°C to $+150^\circ\text{C}$ *
Junction Temperature, (continuous), T_J	$+165^\circ\text{C}$
(100 s), T_{JM}	$+180^\circ\text{C}$
Storage Temperature, T_S	$+170^\circ\text{C}$

* Operation at increased supply voltages with external circuitry is described in Applications Information. Devices for operation at increased temperatures are available on special order.

The ATS622LSB is an optimized Hall-effect sensing integrated circuit and magnet combination that provides a user-friendly solution for true zero-speed digital gear-tooth sensing. The sensor module consists of a plastic shell that holds together a samarium-cobalt magnet, a pole piece, and a Hall-effect sensor that has been optimized to the magnetic circuit. This small package can be easily assembled and used in conjunction with a wide variety of gear shapes and sizes.

The integrated circuit incorporates a dual-element Hall-effect sensor and signal processing that switches in response to differential magnetic signals created by the ferrous gear teeth. The circuitry contains a sophisticated digital circuit to eliminate magnet and system offsets and to achieve true zero-speed operation (manufactured under U.S. Pat. 5,917,320). A-to-D and D-to-A converters are used to adjust the device gain at power on and to allow air-gap independent switching, which greatly reduces vibration sensitivity of the device.

This sensor system is ideal for obtaining transmission and crank information using gear-tooth-based configurations.

FEATURES AND BENEFITS

- Tight timing accuracy over temperature
- True zero-speed operation
- Air-gap independent switch points
- High vibration immunity
- Extremely precise duty cycle signal with temperature
- Large operating air gaps
- Defined power-on state
- Wide operating voltage range
- Digital output representing gear profile
- Single-chip sensing IC for high reliability
- Small mechanical size (9 mm diameter x 7 mm length)
- Optimized magnetic circuit
- $<200 \mu\text{s}$ power-on time
- AGC and reference-adjust circuit
- Under-voltage lockout

*Some restrictions may apply to certain types of sales.
Contact factory for details.*

Always order by complete part number: **ATS622LSB**.

ATS622LSB TRUE ZERO-SPEED, GEAR-TOOTH SENSOR

FUNCTIONAL BLOCK DIAGRAM

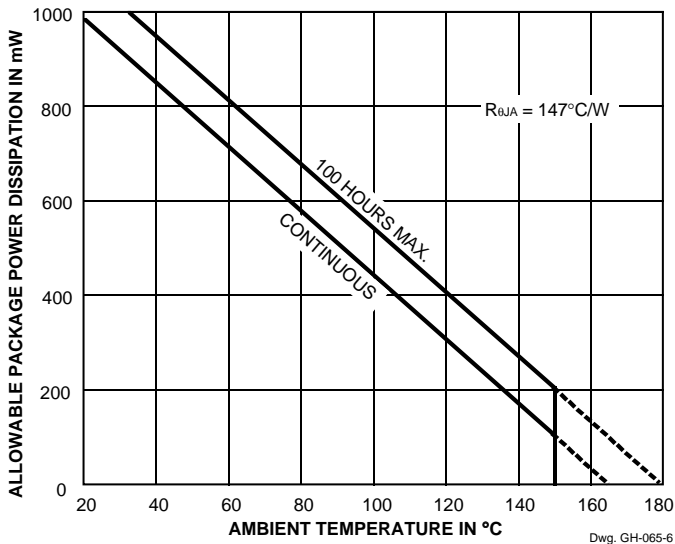
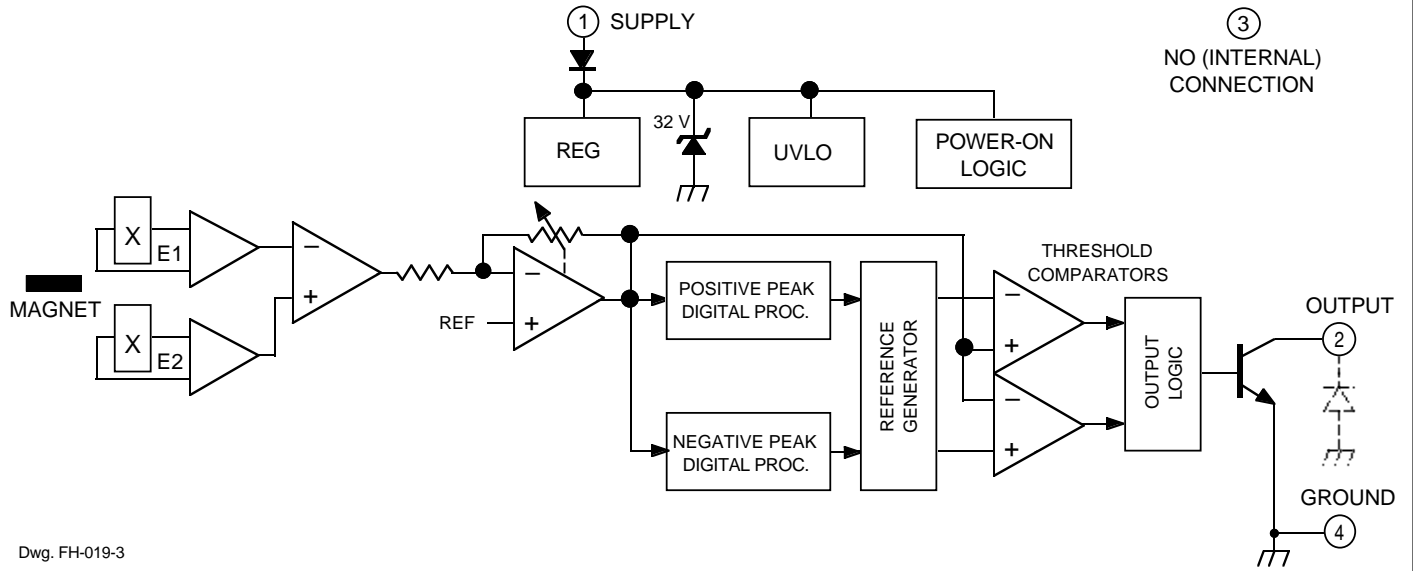

ATS622LSB
TRUE ZERO-SPEED,
GEAR-TOOTH SENSOR

ELECTRICAL CHARACTERISTICS at $T_A = +25^\circ\text{C}$ (unless otherwise noted).

Characteristic	Symbol	Test Conditions	Limits			
			Min.	Typ.	Max.	Units
Supply Voltage	V_{CC}	Operating, $T_J < 165^\circ\text{C}$	4.5	12	24	V
Power-On State	POS	$V_{CC} = 0 \rightarrow 5\text{ V}$	OFF	OFF	OFF	–
Under-Voltage Lockout	$V_{CC(UV)}$	$V_{CC} = 0 \rightarrow 5\text{ V}$	4.1	4.2	4.3	V
Low Output Voltage	$V_{OUT(SAT)}$	$I_{OUT} = 20\text{ mA}$	–	0.2	0.4	V
Output Current Limit	I_{OUTM}	$V_{OUT} = 12\text{ V}$	25	45	55	mA
Output Leakage Current	I_{OFF}	$V_{OUT} = 24\text{ V}$	–	0.2	10	μA
Supply Current	I_{CC}	Output off	3.5	7.0	12	mA
		Output on	5.0	8.5	14	mA
Output Rise Time	t_r	$R_L = 500\ \Omega$, $C_L = 10\text{ pF}$	–	0.2	5.0	μs
Output Fall Time	t_f	$R_L = 500\ \Omega$, $C_L = 10\text{ pF}$	–	0.2	5.0	μs
Power-On Time	t_{on}	Reference gear, $<100\text{ rpm}$	–	–	200	μs
Zener Voltage	V_Z	$I_{ZT} = \text{TBD}$	–	32	–	V

ATS622LSB
TRUE ZERO-SPEED,
GEAR-TOOTH SENSOR

OPERATION over operating voltage and temperature range with reference target (unless otherwise noted)

Characteristic	Symbol	Description	Limits			
			Min.	Typ.	Max.	Units
Air Gap Range	AG	Operating, target speed > 20 RPM	0.5	–	2.5	mm
Calibration Cycle	n_{cal}	Output edges before which calibration is completed*	1	1	1	Edge
Calibration Update	n_r	Output falling edges for startup calibration to be complete	64	64	64	Edges
Minimum Speed	n_{min}		–	0	–	r/s
Maximum Speed	n_{max}	60 teeth per second = 1 r/s	–	133	–	r/s
Timing Accuracy	t_{θ}	Target speed = 1000 rpm, 0.5 mm < AG < 2.5 mm	–	±0.2	±0.5	°

* Non-uniform magnetic profiles may require additional output pulses before calibration is completed.

REFERENCE GEAR DIMENSIONS (60-0)

Characteristic	Symbol	Description	Limits			
			Min.	Typ.	Max.	Units
Diameter	D_o		–	120	–	mm
Tooth Width	T		–	3.0	–	mm
Valley Width	$(p_c - T)$		–	3.0	–	mm
Valley Depth	h_t		–	3.0	–	mm
Thickness	F		3.0	–	–	mm

ATS622LSB TRUE ZERO-SPEED, GEAR-TOOTH SENSOR

TYPICAL CHARACTERISTICS

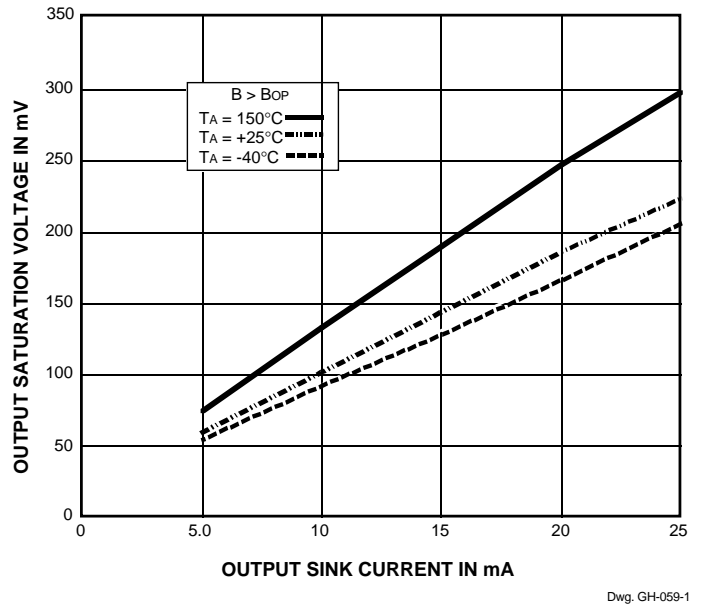
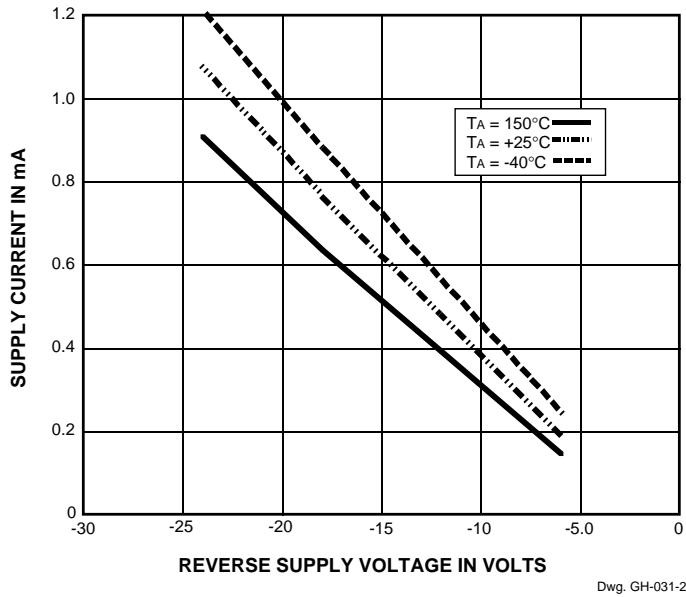
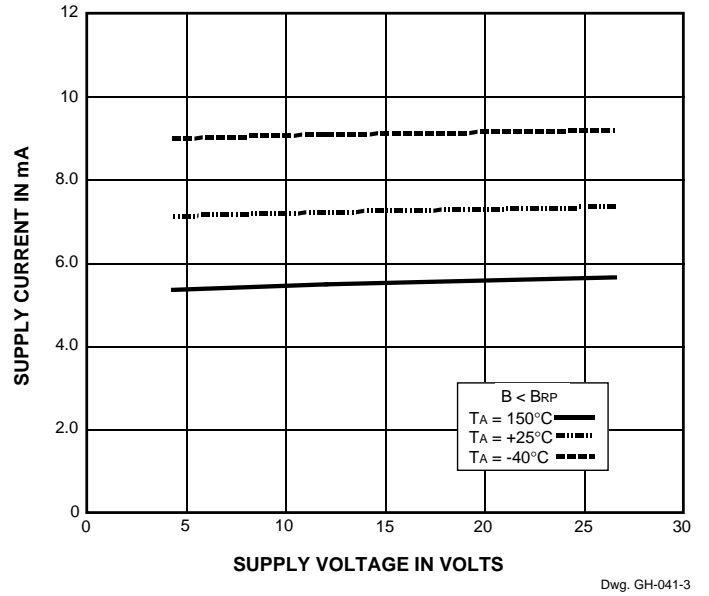
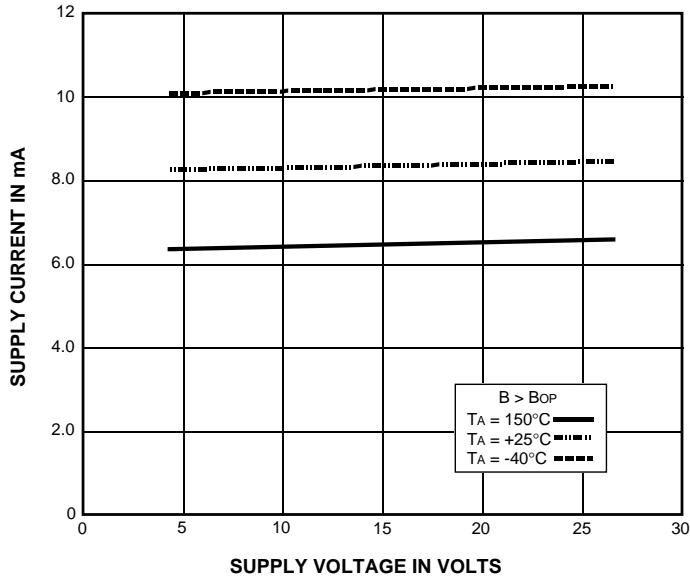

ATS622LSB

TRUE ZERO-SPEED, GEAR-TOOTH SENSOR

DEVICE DESCRIPTION

Module description. The ATS622LSB true zero-speed gear-tooth sensor system is a Hall IC plus magnet configuration that is fully optimized to provide digital detection of gear-tooth* edges in a small package size. The sensor is packaged in a miniature plastic housing that has been optimized for size, ease of assembly, and manufacturability. High operating-temperature materials are used in all aspects of construction.

The use of the sensor is simple. After correct power is applied to the component, it is capable of instantly providing digital information that is representative of the profile of a rotating gear. No additional optimization or processing circuitry is required. This ease of use should reduce design time and incremental assembly costs for most applications.

Sensing technology. The gear-tooth sensor module contains a single-chip differential Hall-effect sensor IC, a samarium-cobalt magnet, and a flat ferrous pole piece. The Hall IC consists of two Hall elements spaced 2.2 mm apart, located so as to measure the magnetic gradient created by the passing of a ferrous object (a gear tooth). The two elements measure the field gradient and convert it to a voltage that is then processed to provide a digital output signal.

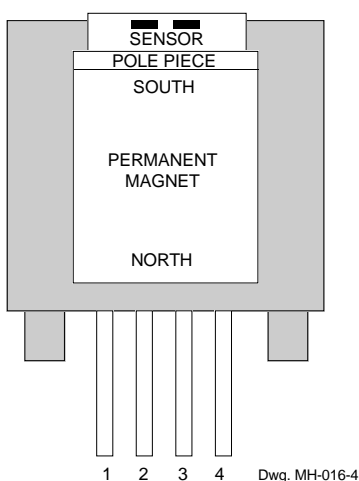

* In application, the terms “gear” and “target” are often interchanged. However, “gear” is preferred when motion is transferred.

Internal electronics. The ATS622LSB is a self-calibrating sensor that contains two Hall-effect elements, a temperature-compensated amplifier, and offset cancellation circuitry. Also contained in the device is a voltage regulator to provide supply rejection over the operating voltage range.

The self-calibrating circuitry is unique. After power up, the device measures the peak-to-peak magnetic signal and adjusts the gain using an on-chip D-to-A converter to make the internal signal amplitude constant independent of the installation air gap of the sensor. This feature allows air-gap-independent operational characteristics.

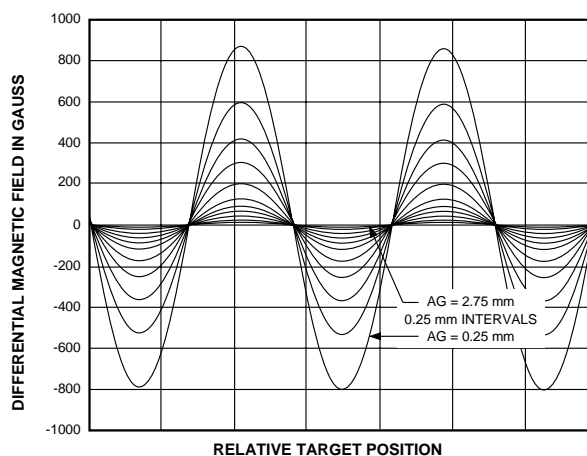

Dwg. GH-061-2

Magnetic signal before gain control

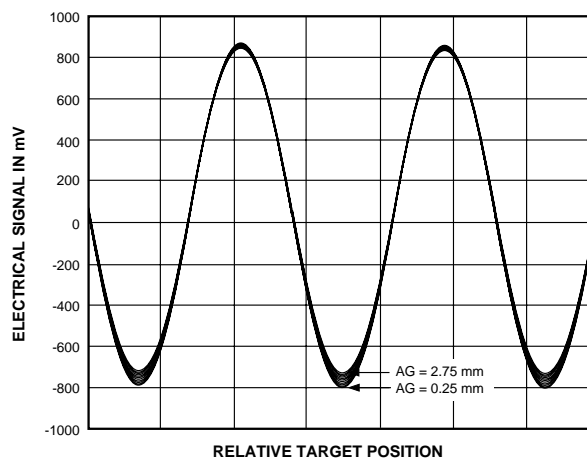

Dwg. GH-061-3

Magnetic signal after gain control

DEVICE DESCRIPTION — Continued

In addition to the gain control circuitry, the device also has provisions to zero out chip, magnet, and installation offsets. This is accomplished using two D-to-A converters that capture the peak and valley of the signal and use them as a reference for the switching comparator. This allows the switch points to be precisely controlled independent of air gap or temperature.

The two Hall transducers and the electronics are integrated on a single silicon substrate using a proprietary BiCMOS process.

Solution advantages. The ATS622LSB true zero-speed detecting gear-tooth sensor uses a differential Hall-element configuration. This configuration is superior in most applications to a classical single-element GTS. The single-element configuration commonly used requires the detection of an extremely small signal (often <100 G) that is superimposed on an extremely large back biased field, often 1500 G to 3500 G. For most gear configurations, the back-biased field values change due to concentration effects, resulting in a varying baseline with air gap, with valley widths, with eccentricities, and with vibration. The differential configuration eliminates the effects of the back-biased field through subtraction and, hence, avoids the issues presented by the single Hall element. The signal-processing circuitry also greatly enhances the functionality of this device. Other advantages are

- temperature drift — changes in temperature do not greatly affect this device due to the stable amplifier design and the offset rejection circuitry,
- timing accuracy/duty cycle variation due to air gap — the accuracy variation caused by air-gap changes is minimized by the self-calibration circuitry. A two-to-three times improvement can be seen over conventional zero-crossing detectors,
- dual edge detection — because this device references the positive and negative peaks of the signal, dual edge detection is guaranteed,
- tilted or off-center installation — traditional differential sensors will switch incorrectly due to baseline changes versus air gap caused by tilted or off-center installation. The self-calibration feature will eliminate the effect of

tilted installation by readjusting the switch points to the new signal,

- large operating air gaps — operating air gaps greater than 2.5 mm are easily achievable with this device due to the sensitive switch points after start up,
- immunity to magnetic overshoot — the air-gap independent hysteresis minimizes the impact of overshoot on the switching of device output,
- response to surface defects in the gear — the gain-adjust circuitry reduces the effect of minor gear anomalies that would normally causes false switching,
- immunity to vibration and backlash — the gain-adjust circuitry keeps the hysteresis of the device roughly proportional to the peak-to-peak signal. This allows the device to have good immunity to vibration even when operating at close air gaps,
- immunity to gear run out — the differential-sensor configuration eliminates the base-line variations caused by gear run out, and
- use with stamped-gear configurations — the high-sensitivity switch points allow the use of stamped gears. The shallow mechanical slopes created by the stamping process create an acceptable magnetic gradient down to zero speed. The surface defects caused by stamping the gear are ignored through the use of gain-control circuitry.

Operation versus air-gap/tooth geometry. Operating specifications are impacted by tooth size, valley size and depth, gear material, and gear thickness. In general, the following guidelines should be followed to achieve greater than 2 mm air gap from the face of unit:

- tooth width (T) > 2 mm;
- valley width ($p_c - T$) > 2 mm;
- valley depth (h_v) > 2 mm;
- gear thickness (F) > 3 mm; and the
- gear material must be low-carbon steel.

Signal duty cycle. For regular tooth geometry, precise duty cycle is maintained over the operating air-gap and temperature range due to an extremely good symmetry in the magnetic switch points of the device. For irregular tooth geometry, there will a small but noticeable change in pulse width versus air gap.

ATS622LSB

TRUE ZERO-SPEED, GEAR-TOOTH SENSOR

DEVICE DESCRIPTION — Continued

Power-on state operation. The device is guaranteed to power on (power up) in the off state (high output voltage) regardless of the presence or absence of a gear tooth. Note that the circuit is ready to accurately detect the first gear edge that results in a tooth-to-valley transition after the circuit has successfully powered on.

Under-voltage lockout. If the supply voltage falls below the under-voltage lockout ($V_{CC(UV)}$), the device output will turn off (high output voltage) and stay off irrespective of the state of the magnetic field. This prevents false signals caused by under-voltage conditions from propagating through to the output of the sensor.

Output. The output of the module is a short-circuit-protected open-collector stage capable of sinking 20 mA. An external pull-up (resistor) to a supply voltage of not more than 24 V must be supplied.

Output polarity. The output of the device will switch from off to on as the leading edge of the target passes the sensor in the direction indicated (pin 4 to pin 1), which means that the output current will be low when the unit is facing a tooth. If rotation is in the opposite direction (pin 1 to pin 4), the output of the device will switch from on to off as the leading edge of the target passes the sensor, which means that the output voltage will be low when the unit is facing a tooth.

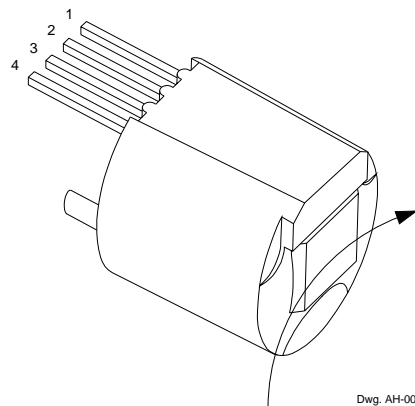

Dwg. AH-006-1

APPLICATIONS INFORMATION

Power supply protection. The device contains an on-chip regulator and can operate over a wide supply voltage range. For devices that need to operate from an unregulated power supply, transient protection should be added externally. For applications using a regulated line, EMI/RFI protection is still required. Incorrect protection can result in unexplained pulses on the output line, providing inaccurate sensing information to the user.

EMI protection circuitry can easily be added to a PC board for use with this device. Provisions have been made for easy mounting of this board on the back of the unit. PC board installation parallel to the device axis is also possible.

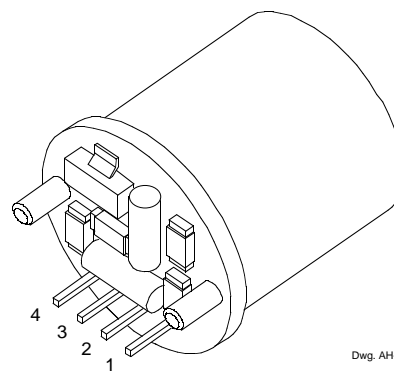

Dwg. AH-007

APPLICATIONS INFORMATION — Continued

Recommended evaluation technique. The self-calibrating feature of the ATS622LSB requires that a special evaluation technique be used to measure its high-accuracy performance capabilities. Installation inaccuracies are calibrated out at power on; hence, it is extremely important that the device be repowered at each air gap when gathering timing accuracy data.

The ATS622LSB is designed to minimize performance variation (caused by the large air-gap variations resulting from installation) by self-calibrating at power-on. These functions should be tested using the procedures described below.

Timing accuracy capabilities after correct self-calibration can be measured as follows:

1. Set the air gap to the desired value.
2. Power down and then power up the device.
3. Rotate the gear at the desired speed.
4. Wait for calibration to complete (128 output pulses to occur).
5. Monitor output for correct switching and measure accuracy.
6. Repeat the above for multiple air gaps within the operating range of the device.
7. This can be repeated over the entire operating temperature range.

There is an internal update algorithm that will maintain the correct duty cycle as air gap changes with temperature. Large changes in air gap will require the part to reset (by cycling power) to maintain the correct duty cycle.

Measurement of the effect of changing air gap after power up:

1. Set the air gap to the desired value (nominal, for example). Rotate the target at the desired speed. Apply power to the module. Wait for 128 output pulses to occur. Monitor output for correct switching and measure accuracy.
2. Change the air gap by ± 0.25 mm. Do not re-power the module. Wait for update algorithm to finish adjusting thresholds, typically 2 to 3 rotations on a 60-tooth gear.

Operation with fine-pitch gears. For targets with a circular pitch of less than 4mm, a performance improvement can be observed by rotating the front face of the sensor. This sensor rotation decreases the effective sensor-to-sensor spacing and increases the capability of detecting fine tooth or valley configurations, provided that the Hall elements are not rotated beyond the width of the target.

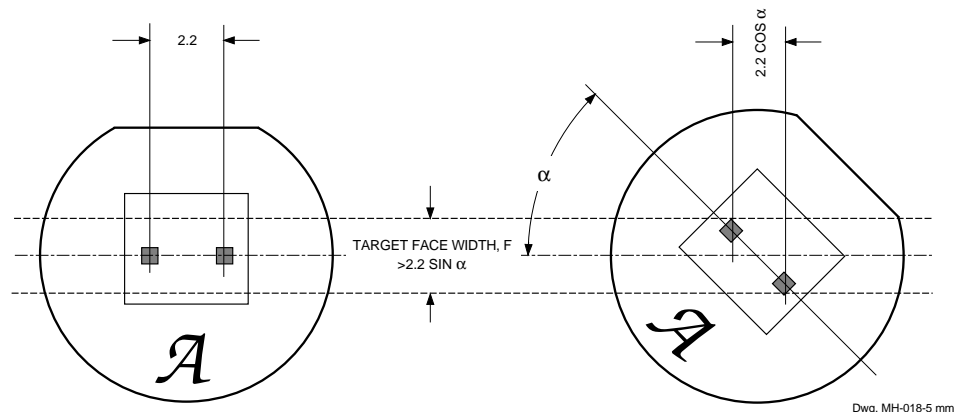

ATS622LSB

TRUE ZERO-SPEED, GEAR-TOOTH SENSOR

APPLICATIONS INFORMATION — Continued

Signal timing accuracy. The magnetic field profile width is defined by the sensor element spacing and narrows in degrees as the target diameter increases. This results in improved timing accuracy performance for larger gear diameters (for the same number of gear teeth). Valley-to-tooth transitions will generally provide better accuracy than tooth-to-valley transitions for large-tooth or large-valley configurations. For highest accuracy, targets greater than 100mm in diameter should be used.

Signal duty cycle. For repetitive target structures, precise duty cycle is maintained over the operating air gap and temperature range due to an extremely good symmetry in the magnetic switch points and the internal self calibration of the device. For irregular tooth geometries, there will be a small but measureable change in pulse width versus air gap.

Additional applications Information on gear-tooth and other Hall-effect sensors is also available in the “Hall-Effect IC Applications Guide”, which can be found in the latest issue of the Allegro MicroSystems Electronic Data Book, AMS-701 or Application Note 27701, or at

www.allegromicro.com

CRITERIA FOR DEVICE QUALIFICATION

All Allegro sensors are subjected to stringent qualification requirements prior to being released to production. To become qualified, except for the destructive ESD tests, no failures are permitted.

Qualification Test	Test Method and Test Conditions	Test Length	Samples Per Lot	Comments
Temperature Humidity Bias Life	JESD22-A101, $T_A = 85^{\circ}\text{C}$, RH = 85%	1000 hrs	48	Device biased for minimum power
Bias Life (Surge Operating Life)	JESD22-A108, $T_A = 150^{\circ}\text{C}$, $T_J = 165^{\circ}\text{C}$	1000 hrs	48	
	JESD22-A108, $T_A = 175^{\circ}\text{C}$, $T_J = 190^{\circ}\text{C}$	168 hrs	48	
Autoclave, Unbiased	JESD22-A102, $T_A = 121^{\circ}\text{C}$, 15 psig	96 hrs	48	
High-Temperature (Bake) Storage Life	JESD22-A103, $T_A = 170^{\circ}\text{C}$	1000 hrs	48	
Temperature Cycle	JESD22-A104	1000 cycles	60	-55°C to $+150^{\circ}\text{C}$
ESD, Human Body Model	CDF-AEC-Q100-002	Pre/Post Reading	3 per test	Test to failure All leads > x kV

ATS622LSB
TRUE ZERO-SPEED,
GEAR-TOOTH SENSOR

MECHANICAL INFORMATION

Component	Material	Function	Units
Sensor Face	Thermoset epoxy	Maximum temperature	170°C*
Plastic Housing	Thermoplastic PBT	264 psi deflection temp. (DTUL) 66 psi deflection temp. (DTUL) Approximate melting temperature	204°C 216°C 225°C
Leads	Copper	—	—
Lead Finish	90/10 tin/lead solder plate	—	†
Lead Pull	—	—	8 N

*Temperature excursions to 225 °C for 2 minutes or less are permitted.

† All industry-accepted soldering techniques are permitted for these modules provided the indicated maximum temperature for each component (e.g., sensor face, plastic housing) is not exceeded. Reasonable dwell times, which do not cause melting of the plastic housing, should be used.

Sensor location (in millimeters)

(sensor location relative to package center is the design objective)

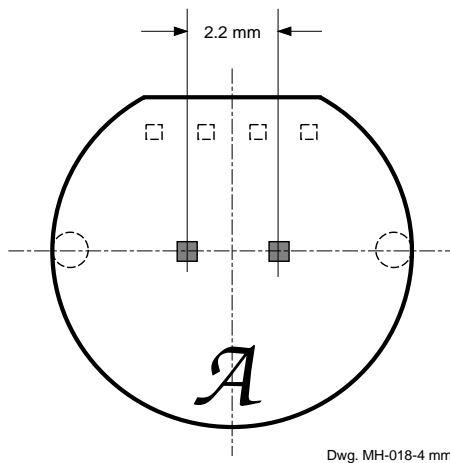

Lead cross section (in millimeters)

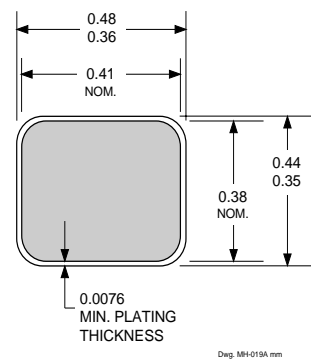

ATS622LSB TRUE ZERO-SPEED, GEAR-TOOTH SENSOR

DIMENSIONS IN MILLIMETERS

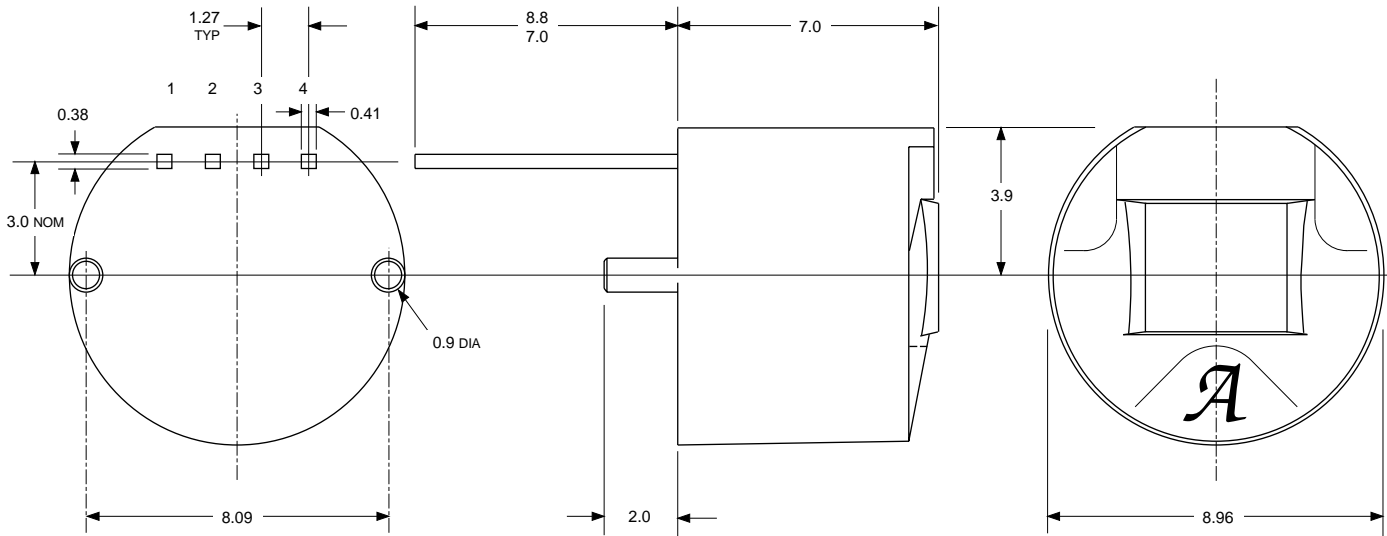

Dwg. MH-017-1B mm

Tolerances, unless otherwise specified: 1 place ± 0.1 mm, 2 places ± 0.05 mm.

The products described herein are manufactured under one or more of the following U.S. patents: 5,045,920; 5,264,783; 5,442,283; 5,389,889; 5,581,179; 5,517,112; 5,619,137; 5,621,319; 5,650,719; 5,686,894; 5,694,038; 5,729,130; 5,917,320; and other patents pending.

Allegro MicroSystems, Inc. reserves the right to make, from time to time, such departures from the detail specifications as may be required to permit improvements in the performance, reliability, or manufacturability of its products. Before placing an order, the user is cautioned to verify that the information being relied upon is current.

Allegro products are not authorized for use as critical components in life-support appliances, devices, or systems without express written approval.

The information included herein is believed to be accurate and reliable. However, Allegro MicroSystems, Inc. assumes no responsibility for its use; nor for any infringements of patents or other rights of third parties that may result from its use.