



AZ100LVEL16VT ARIZONA MICROTEK, INC.

ECL/PECL Oscillator Gain Stage & Buffer with Selectable Enable

FEATURES

- High Bandwidth for $\geq 1\text{GHz}$
- **Similar Operation as AZ100LVEL16VR except in Disabled Condition: Q_{HG} is High**
- Operating Range of 3.0V to 5.5V
- Minimizes External Components
- Selectable Enable Polarity and Threshold (CMOS/TTL or PECL)
- Available in a 3x3 mm or 2x2 mm MLP Package
- S-Parameter (.s2p) and IBIS Model Files Available on Arizona Microtek Website

PACKAGE AVAILABILITY

PACKAGE	PART NUMBER	MARKING	NOTES
MLP 8 (2x2x0.75)	AZ100LVEL16VTNA	P9 <Date Code>	1,2,3
MLP 8 (2x2x0.75) RoHS Compliant / Lead (Pb) Free	AZ100LVEL16VTNA+	P9+ <Date Code>	1,2
MLP 8 (2x2x0.75)	AZ100LVEL16VTNB	P8 <Date Code>	1,2,4
MLP 8 (2x2x0.75) RoHS Compliant / Lead (Pb) Free	AZ100LVEL16VTNB+	P8+ <Date Code>	1,2
MLP 8 (2x2x0.75)	AZ100LVEL16VTNC	P2 <Date Code>	1,2,5
MLP 8 (2x2x0.75) RoHS Compliant / Lead (Pb) Free	AZ100LVEL16VTNC+	P2+ <Date Code>	1,2
MLP 8 (2x2x0.75)	AZ100LVEL16VTND	P3 <Date Code>	1,2
MLP 8 (2x2x0.75) RoHS Compliant / Lead (Pb) Free	AZ100LVEL16VTND+	P3+ <Date Code>	1,2
MLP 16 (3x3)	AZ100LVEL16VTL	AZM 16T <Date Code>	1,2
MLP 16 (3x3) RoHS Compliant / Lead (Pb) Free	AZ100LVEL16VTL+	AZM+ 16T <Date Code>	1,2
DIE	AZ100LVEL16VTXP	N/A	6

- 1 Add R1 at end of part number for 7 inch (1K parts), R2 for 13 inch (2.5K parts) Tape & Reel.
- 2 Date code format: "Y" or "YY" for year followed by "WW" for week.
- 3 Parts marked TNA for date codes prior to 4WW (prior to 2004).
- 4 Parts marked TNB for date codes prior to 4WW (prior to 2004).
- 5 Parts marked TNC for date codes prior to 4WW (prior to 2004).
- 6 Waffle Pack

DESCRIPTION

The AZ100LVEL16VT is a specialized oscillator gain stage with high gain output buffer including an enable. The Q_{HG}/\bar{Q}_{HG} outputs have a voltage gain several times greater than the Q/\bar{Q} outputs.

MLP 16, 3x3 mm Package (VTL) or DIE (VTX)

The AZ100LVEL16VTL and AZ100LVEL16VTX provide a selectable enable input (EN) that allows continuous oscillator operation. See truth table for the Enable function. If Enable pull-up is desired in the CMOS/TTL mode, an external $\leq 20\text{ k}\Omega$ resistor connecting EN to V_{CC} will override the on-chip pull-down resistor. When disabled, the Q_{HG} output is forced high and the \bar{Q}_{HG} output is forced low. The AZ100LVEL16VTL/VTX also provides a V_{BB} and 470 Ω internal bias resistors from D to V_{BB} and \bar{D} to V_{BB} . The V_{BB} pin can support 1.5 mA sink/source current. Bypassing V_{BB} to ground with a 0.01 μF capacitor is recommended.

The outputs Q and \bar{Q} each have a selectable on-chip pull-down current source. See truth table below for current source functions. External resistors may also be used to increase pull-down current to a maximum total of 25 mA.

AZ100LVEL16VT

Outputs Q_{HG} and \bar{Q}_{HG} each have an optional on-chip pull-down current source of 10 mA. When pad/pin V_{EEP} is left open (NC), the output current sources are disabled and the Q_{HG}/\bar{Q}_{HG} operate as standard PECL/ECL. When V_{EEP} is connected to V_{EE} , the current sources are activated. The Q_{HG}/\bar{Q}_{HG} pull-down current can be decreased, by using a resistor to connect V_{EEP} to V_{EE} . (See graph on page 5.)

MLP 8, 2x2 mm Package, VTNA, VTNB, VTNC & VTND Versions

All MLP 8, 2x2mm versions of the AZ100LVEL16VT provide an enable input that allows continuous oscillator operation. VTNA and VTNB utilize an enable (\bar{EN}) that operates in the PECL/ECL mode. When the \bar{EN} input is LOW, the \bar{Q} and Q_{HG}/\bar{Q}_{HG} outputs follow the data inputs. When \bar{EN} is HIGH, the Q_{HG} output is forced high and the \bar{Q}_{HG} output is forced low. VTNC and VTND utilize an enable (EN) that operates in the CMOS/TTL mode. When the EN input is HIGH, the \bar{Q} and Q_{HG}/\bar{Q}_{HG} outputs follow the data inputs. When EN is LOW, the Q_{HG} output is forced high and the \bar{Q}_{HG} output is forced low.

For VTNA and VTND, both D and \bar{D} inputs are brought out and tied to the V_{BB} pin through 470 Ω internal bias resistors. In VTNB and VTNC, the \bar{D} input is internally tied directly to the V_{BB} pin and the D input is tied to the V_{BB} pin through a 470 Ω internal bias resistor. Bypassing V_{BB} to ground with a 0.01 μ F capacitor is recommended.

All MLP 8, 2x2mm versions (VTNA, VTNB, VTNC & VTND) have the Q, Q_{HG} , and \bar{Q}_{HG} current sources disabled, while the \bar{Q} output operates with a 4 mA current source to V_{EE} .

NOTE: Specifications in the ECL/PECL tables are valid when thermal equilibrium is established.

ENABLE TRUTH TABLE
MLP 16 (VTL) or DIE (VTX)

EN-SEL	EN	Q/Q	Q_{HG}	\bar{Q}_{HG}
NC	PECL Low, V_{EE} or NC	Data	Data	Data
NC	PECL High or V_{CC}	Data	High	Low
V_{EE}^*	CMOS Low or V_{EE}	Data	High	Low
V_{EE}^*	CMOS High or V_{CC}	Data	Data	Data
V_{EE}^*	NC, no external pull-up	Data	High	Low
V_{EE}^*	NC, with $\leq 20k\Omega$ to V_{CC}	Data	Data	Data

*Connections to V_{CC} or V_{EE} must be less than 1 Ω .

PIN DESCRIPTION

PIN	FUNCTION
D/ \bar{D}	Data Inputs
Q/ \bar{Q}	Data Outputs
Q_{HG}/\bar{Q}_{HG}	Data Outputs w/High Gain
V_{BB}	Reference Voltage Output
EN-SEL	Selects Enable Logic
EN/ \bar{EN}	Enable Input
CS-SEL	Selects Q and \bar{Q} Current Source Magnitude
V_{EEP}	Optional Q_{HG} and \bar{Q}_{HG} Current Sources
V_{EE}	Negative Supply
V_{CC}	Positive Supply

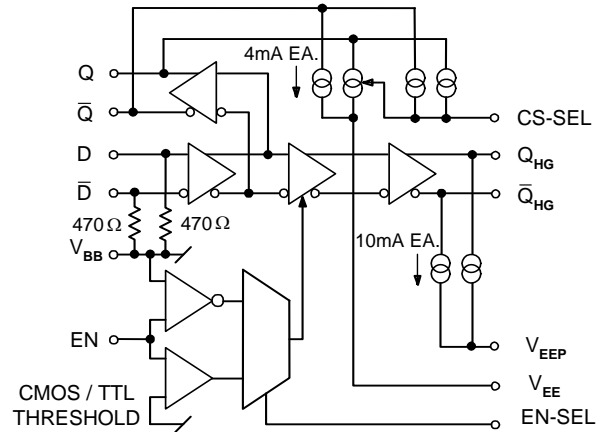

MLP 16 (VTL) or DIE (VTX)

CURRENT SOURCE TRUTH TABLE
MLP 16 (VTL) or DIE (VTX)

CS-SEL	Q	\bar{Q}
NC	4mA typ.	4mA typ.
V_{EE}^*	8mA typ.	8mA typ.
V_{CC}^*	0	4mA typ.

*Connections to V_{CC} or V_{EE} must be less than 1 Ω .

AZ100LVEL16VT

Absolute Maximum Ratings are those values beyond which device life may be impaired.

Symbol	Characteristic	Rating	Unit
V _{CC}	PECL Power Supply (V _{EE} = 0V)	0 to +8.0	Vdc
V _I	PECL Input Voltage (V _{EE} = 0V)	0 to +6.0	Vdc
V _{EE}	ECL Power Supply (V _{CC} = 0V)	-8.0 to 0	Vdc
V _I	ECL Input Voltage (V _{CC} = 0V)	-6.0 to 0	Vdc
I _{OUT}	Output Current Q _{HG} /Q _{HG} --- Continuous	50	mA
	--- Surge	100	
Output Current Q/Q	--- Continuous	25	
--- Surge		50	
T _A	Operating Temperature Range	-40 to +85	°C
T _{STG}	Storage Temperature Range	-65 to +150	°C

100K ECL DC Characteristics (V_{EE} = -3.0V to -5.5V, V_{CC} = GND)

Symbol	Characteristic	-40°C		0°C		25°C		85°C		Unit
		Min	Max	Min	Max	Min	Max	Min	Max	
V _{OH}	Output HIGH Voltage ²	-1045	-835	-995	-835	-995	-835	-995	-835	mV
V _{OH}	Output HIGH Voltage ⁴	-1085	-880	-1025	-880	-1025	-880	-1025	-880	mV
V _{OL}	Output LOW Voltage ^{2,4}	-1925	-1555	-1900	-1620	-1900	-1620	-1900	-1620	mV
V _{IH}	Input HIGH Voltage									
	D/D, EN/EN (PECL) EN (CMOS/TTL)	-1165 V _{EE} +2000	-880 V _{CC}	-1165 V _{EE} +2000	-880 V _{CC}	-1165 V _{EE} +2000	-880 V _{CC}	-1165 V _{EE} +2000	-880 V _{CC}	mV
V _{IL}	Input LOW Voltage									
	D/D, EN/EN (PECL) EN (CMOS/TTL)	-1810 V _{EE}	-1475 V _{EE} + 800	-1810 V _{EE}	-1475 V _{EE} + 800	-1810 V _{EE}	-1475 V _{EE} + 800	-1810 V _{EE}	-1475 V _{EE} + 800	mV
V _{BB}	Reference Voltage	-1390	-1250	-1390	-1250	-1390	-1250	-1390	-1250	mV
I _{IL}	Input LOW Current EN ³	0.5		0.5		0.5		0.5		µA
I _{IH}	Input HIGH Current EN ³		150		150		150		150	µA
I _{EE}	Power Supply Current ¹		48		48		48		54	mA

1. Specified with V_{EEP} and CS-SEL open for VTL and VTX. Subtract 4mA for VTNA, VTNB, VTNC & VTND.
2. Specified with V_{EEP} and CS-SEL connected to V_{EE} for VTL and VTX only.
3. Specified with EN-SEL open for VTL and VTX only.
4. Specified with Q_{HG}/Q_{HG} connected with 50 Ω to V_{CC}-2V for VTNA, VTNB, VTNC & VTND.

100K LVPECL DC Characteristics (V_{EE} = GND, V_{CC} = +3.3V)

Symbol	Characteristic	-40°C		0°C		25°C		85°C		Unit
		Min	Max	Min	Max	Min	Max	Min	Max	
V _{OH}	Output HIGH Voltage ^{1,3}	2255	2465	2305	2465	2305	2465	2305	2465	mV
V _{OH}	Output HIGH Voltage ^{1,5}	2215	2420	2275	2420	2275	2420	2275	2420	mV
V _{OL}	Output LOW Voltage ^{1,3,5}	1375	1745	1400	1655	1480	1680	1400	1680	mV
V _{IH}	Input HIGH Voltage									
	D/D, EN/EN (PECL) ¹ EN (CMOS/TTL)	2135 2000	2420 V _{CC}	2135 2000	2420 V _{CC}	2135 2000	2420 V _{CC}	2135 2000	2420 V _{CC}	mV
V _{IL}	Input LOW Voltage									
	D/D, EN/EN (PECL) ¹ EN (CMOS/TTL)	1490 GND	1825 800	1490 GND	1825 800	1490 GND	1825 800	1490 GND	1825 800	mV
V _{BB}	Reference Voltage ¹	1910	2050	1910	2050	1910	2050	1910	2050	mV
I _{IL}	Input LOW Current EN ⁴	0.5		0.5		0.5		0.5		µA
I _{IH}	Input HIGH Current EN ⁴		150		150		150		150	µA
I _{EE}	Power Supply Current ²		48		48		48		54	mA

1. For supply voltages other than 3.3V, use the ECL table values and ADD supply voltage value.
2. Specified with V_{EEP} and CS-SEL open for VTL and VTX. Subtract 4mA for VTNA, VTNB, VTNC & VTND.
3. Specified with V_{EEP} and CS-SEL connected to V_{EE} for VTL and VTX only.
4. Specified with EN-SEL open for VTL and VTX only.
5. Specified with Q_{HG}/Q_{HG} connected with 50 Ω to V_{CC}-2V for VTNA, VTNB, VTNC & VTND.

AZ100LVEL16VT

100K PECL DC Characteristics ($V_{EE} = \text{GND}$, $V_{CC} = +5.0\text{V}$)

Symbol	Characteristic	-40°C		0°C		25°C		85°C		Unit
		Min	Max	Min	Max	Min	Max	Min	Max	
V_{OH}	Output HIGH Voltage ^{1,3}	3955	4165	4005	4165	4005	4165	4005	4165	mV
V_{OH}	Output HIGH Voltage ^{1,5}	3915	4120	3975	4120	3975	4120	3975	4120	mV
V_{OL}	Output LOW Voltage ^{1,3,5}	3075	3445	3100	3338	3100	3338	3100	3338	mV
V_{IH}	Input HIGH Voltage D/ \bar{D} , EN/ \bar{EN} (PECL) ¹ EN (CMOS/TTL)	3835	4120	3835	4120	3835	4120	3835	4120	mV
		2000	V_{CC}	2000	V_{CC}	2000	V_{CC}	2000	V_{CC}	
V_{IL}	Input LOW Voltage D/ \bar{D} , EN/ \bar{EN} (PECL) ¹ EN (CMOS/TTL)	3190	3525	3190	3525	3190	3525	3190	3525	mV
		GND	800	GND	800	GND	800	GND	800	
V_{BB}	Reference Voltage ¹	3610	3750	3610	3750	3610	3750	3610	3750	mV
I_{IL}	Input LOW Current EN ⁴	0.5		0.5		0.5		0.5		μA
I_{IH}	Input HIGH Current EN ⁴		150		150		150		150	μA
I_{EE}	Power Supply Current ²		48		48		48		54	mA

- For supply voltages other than 5.0V, use the ECL table values and ADD supply voltage value.
- Specified with V_{EEP} and CS-SEL open for VTL and VTX. Subtract 4mA for VTNA, VTNB, VTNC & VTND.
- Specified with V_{EEP} and CS-SEL connected to V_{EE} for VTL and VTX only.
- Specified with EN-SEL open for VTL and VTX only.
- Specified with Q_{HG}/\bar{Q}_{HG} connected with 50 Ω to $V_{CC} - 2\text{V}$ for VTNA, VTNB, VTNC & VTND.

AC Characteristics ($V_{EE} = -3.0\text{V}$ to -5.5V ; $V_{CC} = \text{GND}$ or $V_{EE} = \text{GND}$; $V_{CC} = +3.0\text{V}$ to $+5.5\text{V}$)

Symbol	Characteristic	-40°C			0°C			25°C			85°C			Unit
		Min	Typ	Max	Min	Typ	Max	Min	Typ	Max	Min	Typ	Max	
t_{PLH} / t_{PHL}	Propagation Delay D to Q/ \bar{Q} Outputs ¹ (SE) D to Q_{HG}/\bar{Q}_{HG} Outputs ¹ (SE)			400			400			400			430	ps
				550			550			550			630	
t_{SKEW}	Duty Cycle Skew ² (SE)		5	20		5	20		5	20		5	20	ps
V_{PP}	Minimum Input Swing ³ DIFF SE	80			80			80			80			mV
		160			160			160			160			
t_r / t_f	Output Rise/Fall Times ¹ (20% - 80%)	100		260	100		260	100		260	100		260	ps

- For VTL and VTX, output specified with V_{EEP} and CS-SEL connected to V_{EE} with an AC coupled 50 Ω load. For VTNA, VTNB, VTNC & VTND, AC coupled 50 Ω on Q to $V_{CC} - 2\text{V}$ and DC coupled 50 Ω to $V_{CC} - 2\text{V}$ on Q_{HG}/\bar{Q}_{HG} .
- Duty cycle skew is the difference between a t_{PLH} and t_{PHL} propagation delay through a device.
- V_{PP} is the minimum peak-to-peak input swing for which AC parameters guaranteed. The device has a voltage gain of ≈ 20 to Q/ \bar{Q} outputs and a voltage gain of ≈ 100 to Q_{HG}/\bar{Q}_{HG} outputs.

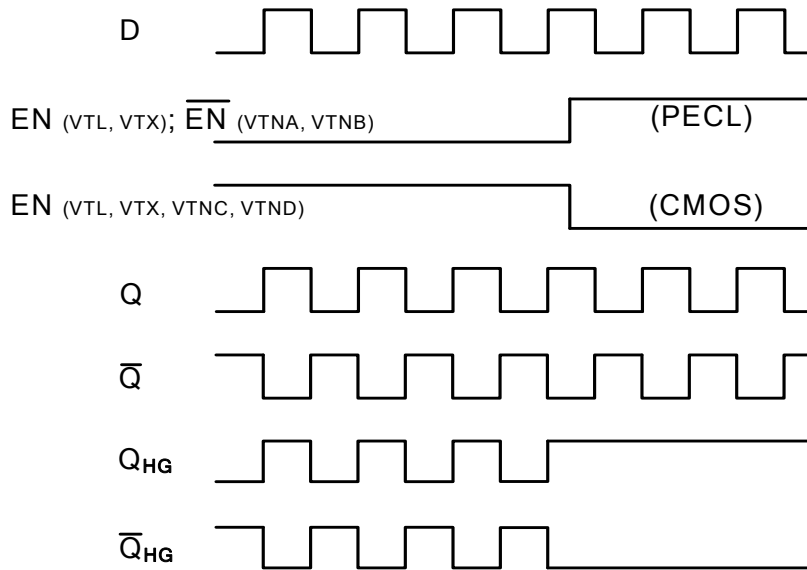

TIMING DIAGRAM

AZ100LVEL16VTL

MLP 16
3x3 mm

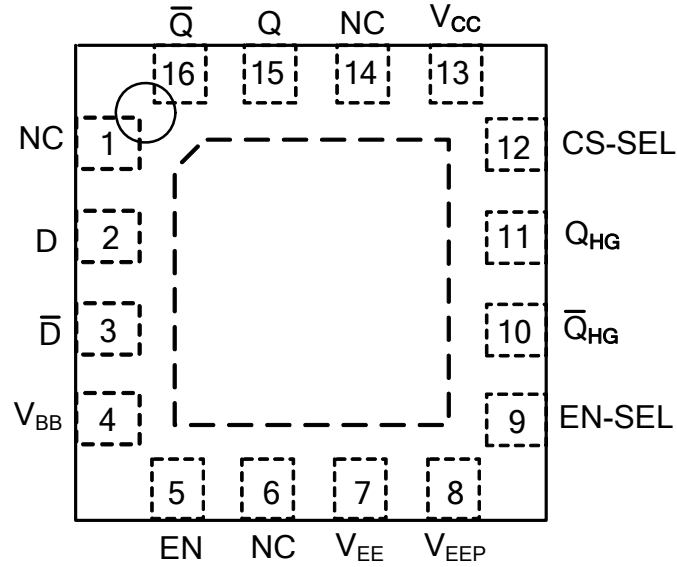

TOP VIEW

Bottom Center Pad may be left open or tied to V_{EE}

ADJUSTABLE HIGH GAIN OUTPUT CURRENT

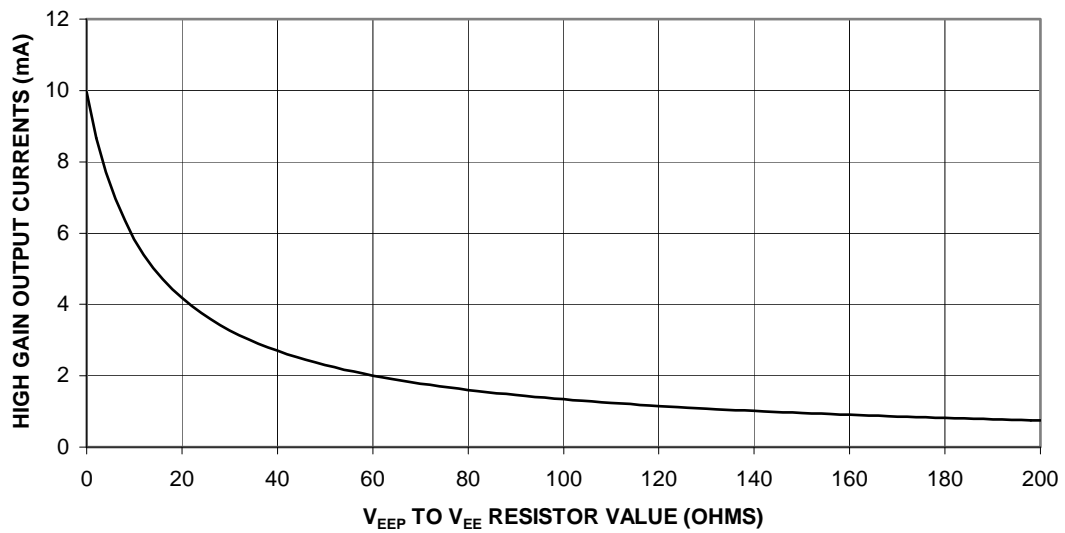

AZ100LVEL16VT

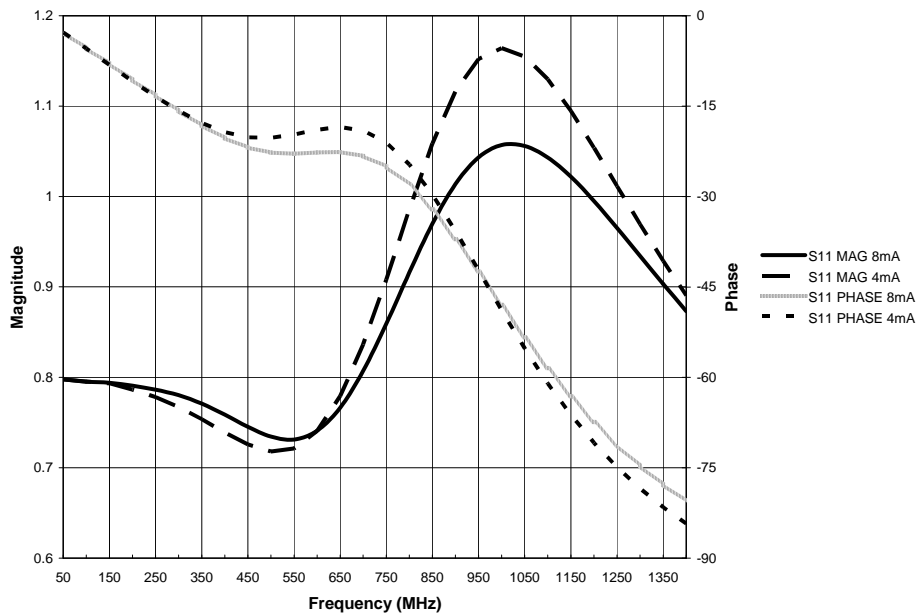

S11, D to Q
(50 Ω external AC, 4 & 8mA internal DC Load on Q)

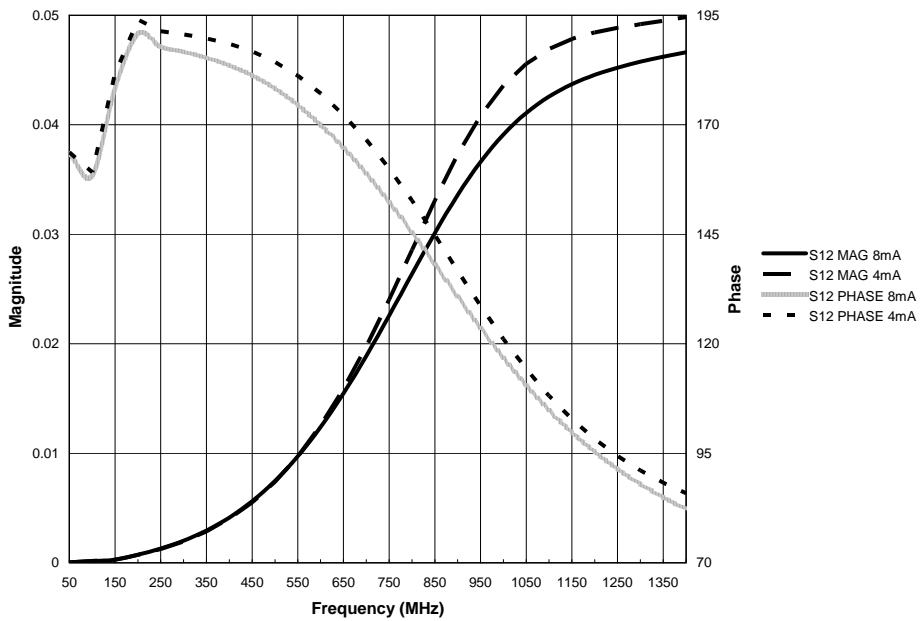

S12, D to Q
(50 Ω external AC, 4 & 8mA internal DC Load on Q)

AZ100LVEL16VT

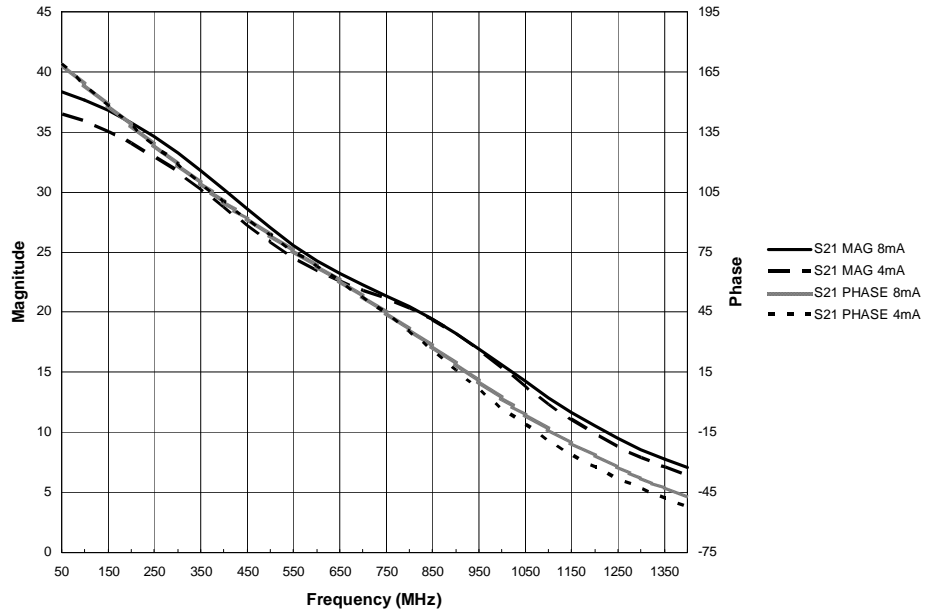

S21, D to Q
(50 Ω external AC, 4 & 8mA internal DC Load on Q)

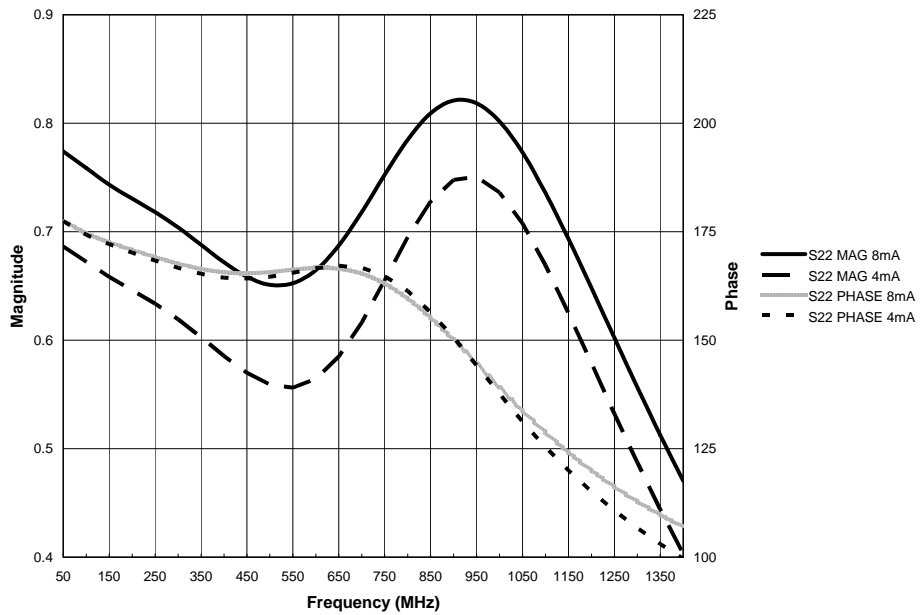

S22, D to Q
(50 Ω external AC, 4 & 8mA internal DC Load on Q)

LOGIC DIAGRAMS AND PINOUTS FOR 2x2mm PACKAGE

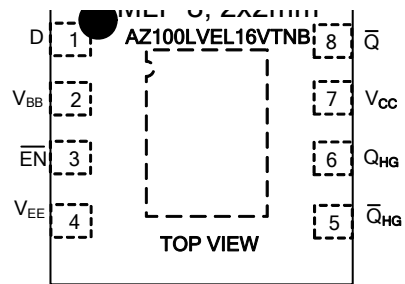
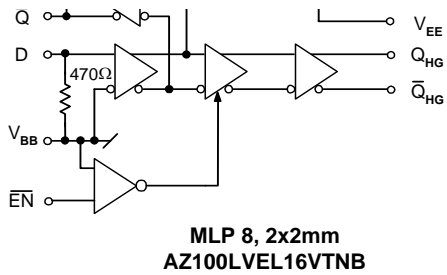
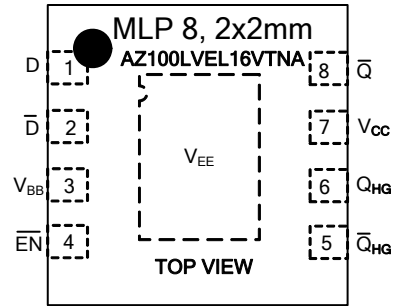
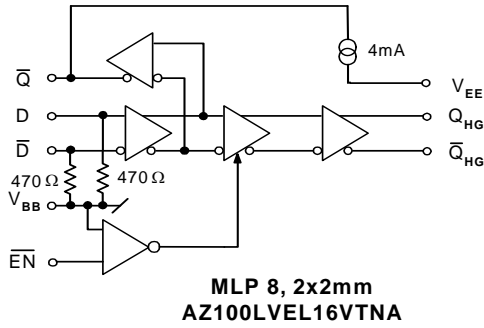

EN operation follows PECL functionality.
See Timing Diagram above.

Bottom Center Pad may be left open
or tied to V_{EE} . Pin 4 is the V_{EE} return.

AZ100LVEL16VT

LOGIC DIAGRAMS AND PINOUTS FOR 2x2mm PACKAGE

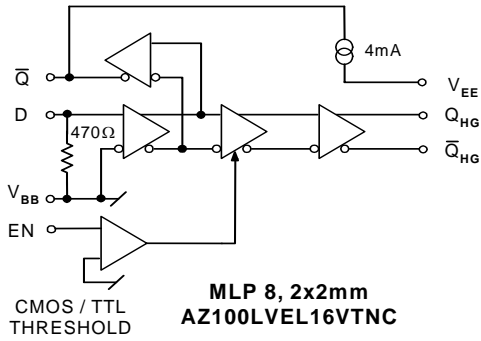

EN operation follows CMOS/TTL functionality. See Timing Diagram above.

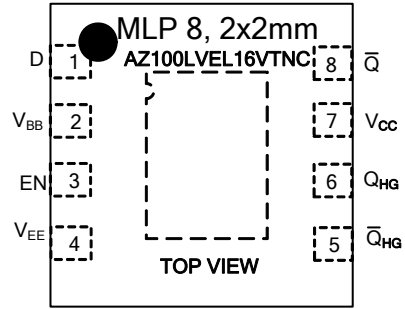

Bottom Center Pad may be left open or tied to V_{EE}. Pin 4 is the V_{EE} return.

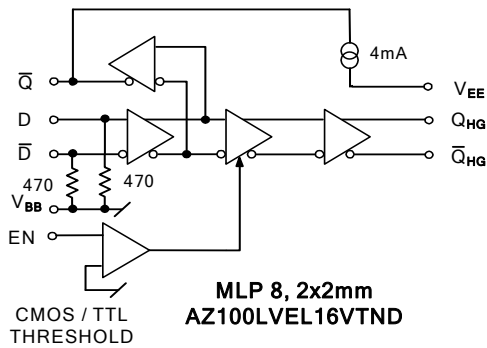

EN operation follows CMOS/TTL functionality. See Timing Diagram above.

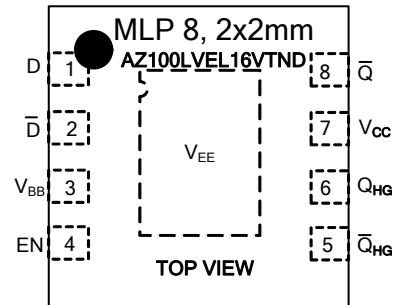

Bottom Center Pad is the V_{EE} return.

AZ100LVEL16VT

DIE PAD COORDINATES

AZ100LVEL16VT DIE:

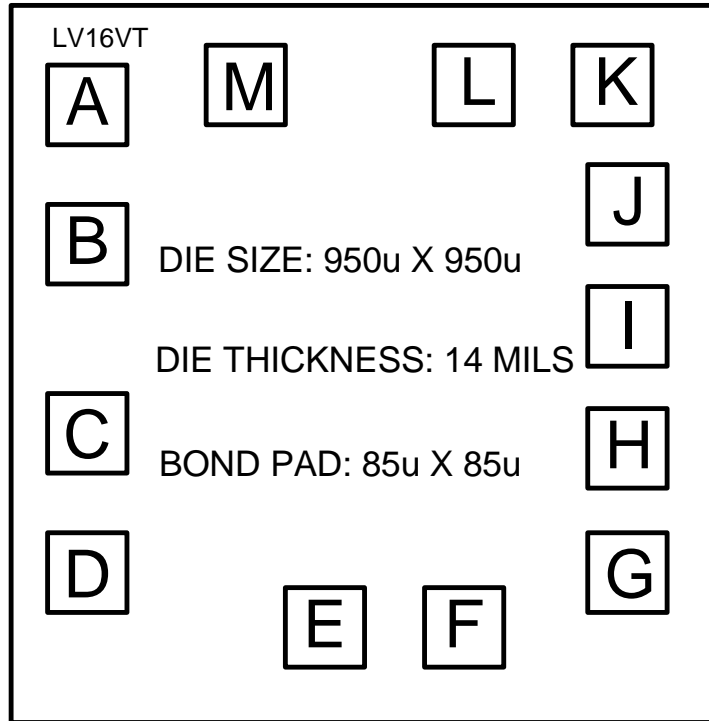

PAD CENTER COORDINATES

NAME	PAD DESIGNATION	X(Microns)	Y(Microns)
A	D	-342.5	312.5
B	\bar{D}	-342.5	144.5
C	V_{BB}	-342.5	-87.0
D	EN	-342.5	-255.0
E	V_{EE}	-33.5	-312.5
F	V_{EEP}	126.5	-312.5
G	EN-SEL	312.5	-248.5
H	\bar{Q}_{HG}	312.5	-98.5
I	Q_{HG}	312.5	51.5
J	CS-SEL	312.5	201.5
K	V_{CC}	302.5	342.5
L	Q	142.5	342.5
M	\bar{Q}	-140.5	342.5

PACKAGE DIAGRAM
MLP 8 2x2mm

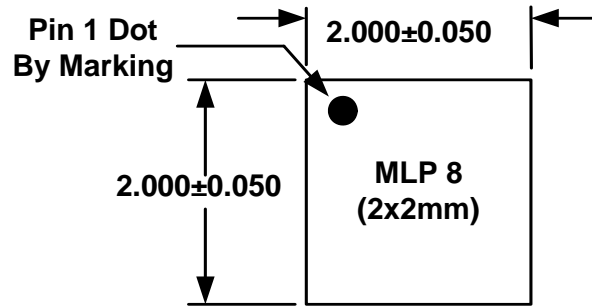

TOP VIEW

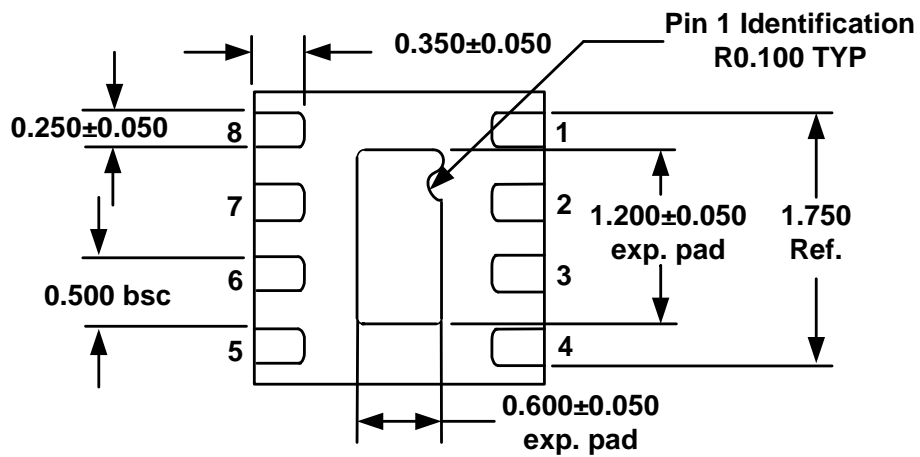

BOTTOM VIEW

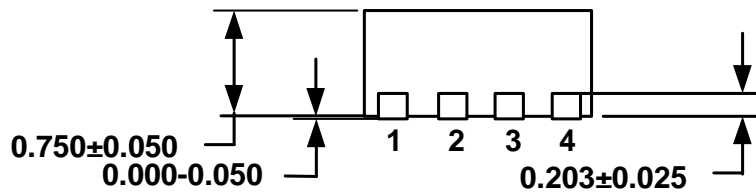

SIDE VIEW

Note: All dimensions are in mm

**PACKAGE DIAGRAM
MLP 16 3X3mm**

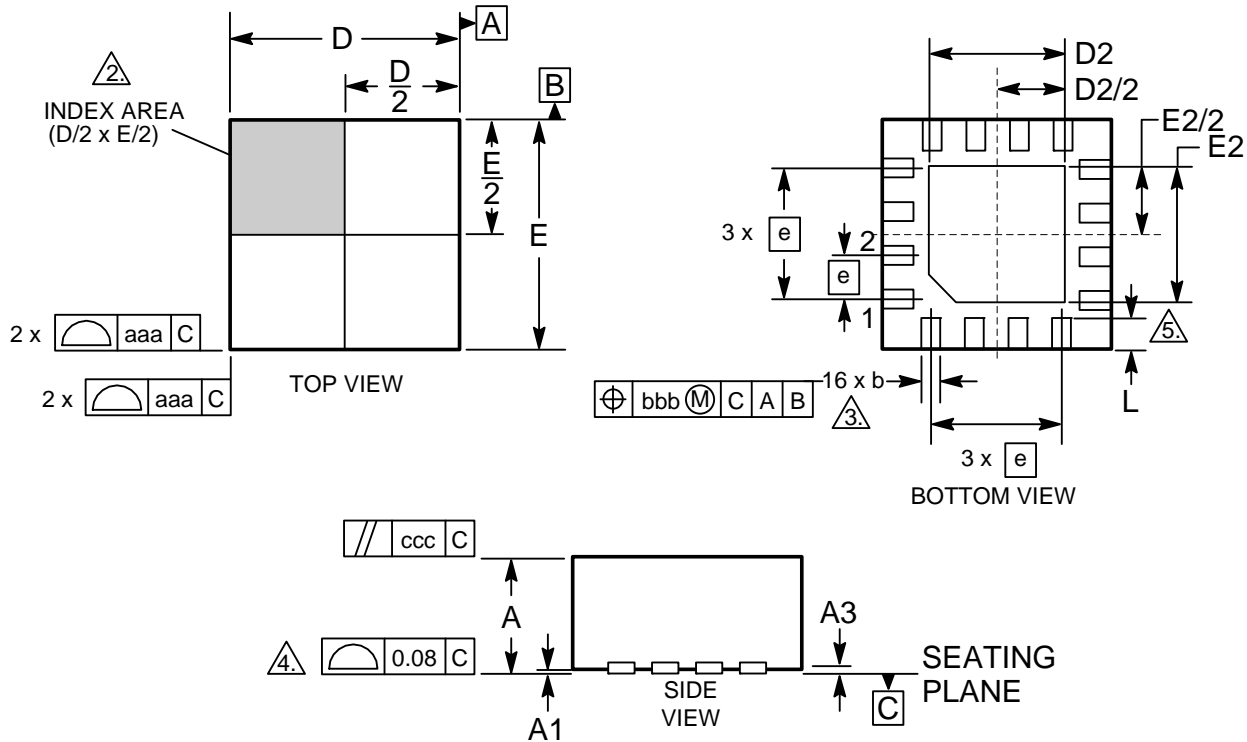

NOTES:

1. DIMENSIONING AND TOLERANCING CONFORM TO ASME T14-1994.
- $\triangle 2$. THE TERMINAL #1 AND PAD NUMBERING CONVENTION SHALL CONFORM TO JESD 95-1 SPP-012.
- $\triangle 3$. DIMENSION b APPLIES TO METALLIZED PAD AND IS MEASURED BETWEEN 0.25 AND 0.30 mm FROM PAD TIP.
- $\triangle 4$. COPLANARITY APPLIES TO THE EXPOSED PADS AS WELL AS THE TERMINALS.
- $\triangle 5$. INSIDE CORNERS OF METALLIZED PAD MAY BE SQUARE OR ROUNDED

DIM	MILLIMETERS	
	MIN	MAX
A	0.80	1.00
A1	0.00	0.05
A3	0.25 REF	
b	0.18	0.30
D	2.90	3.10
D2	0.25	1.95
E	2.90	3.10
E2	0.25	1.95
e	0.50 BSC	
L	0.30	0.50
aaa	0.25	
bbb	0.10	
ccc	0.10	

AZ100LEVEL16VT

Arizona Microtek, Inc. reserves the right to change circuitry and specifications at any time without prior notice. Arizona Microtek, Inc. makes no warranty, representation or guarantee regarding the suitability of its products for any particular purpose, nor does Arizona Microtek, Inc. assume any liability arising out of the application or use of any product or circuit and specifically disclaims any and all liability, including without limitation special, consequential or incidental damages. Arizona Microtek, Inc. does not convey any license rights nor the rights of others. Arizona Microtek, Inc. products are not designed, intended or authorized for use as components in systems intended to support or sustain life, or for any other application in which the failure of the Arizona Microtek, Inc. product could create a situation where personal injury or death may occur. Should Buyer purchase or use Arizona Microtek, Inc. products for any such unintended or unauthorized application, Buyer shall indemnify and hold Arizona Microtek, Inc. and its officers, employees, subsidiaries, affiliates, and distributors harmless against all claims, costs, damages, and expenses, and reasonable attorney fees arising out of, directly or indirectly, any claim of personal injury or death associated with such unintended or unauthorized use, even if such claim alleges that Arizona Microtek, Inc. was negligent regarding the design or manufacture of the part.