

**DUAL BIPOLAR OPERATIONAL AMPLIFIERS****AZ4558C****General Description**

The AZ4558C consists of two high performance operational amplifiers. The IC features high gain, low equivalent input noise voltage, high input resistance, excellent channel separation, wide range of operating voltage and internal frequency compensation.

It can work with  $\pm 18V$  maximum power supply voltage or single power supply up to 36V.

The AZ4558C is available in DIP-8 and SOIC-8 packages.

**Features**

- Internally Frequency Compensated
- Large Signal Voltage Gain: 100dB Typical
- Gain and Phase Match between Amplifiers
- Gain Bandwidth Product (at 10KHz): 5.5MHz
- Pin to Pin Compatible with MC1458

**Applications**

- Audio AC-3 Decoder System
- Audio Amplifier

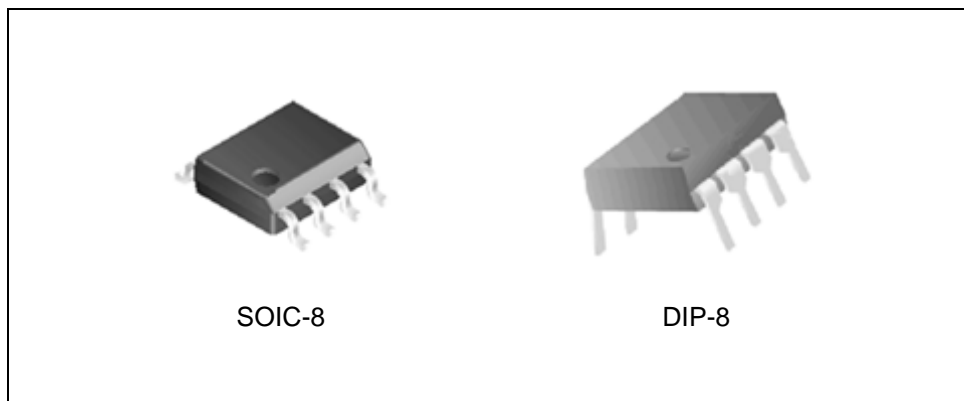

Figure 1. Package Types of AZ4558C



**DUAL BIPOLAR OPERATIONAL AMPLIFIERS**

**AZ4558C**

**Pin Configuration**

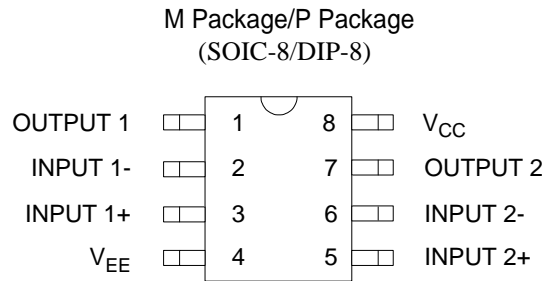

Figure 2. Pin Configuration of AZ4558C (Top View)

**Functional Block Diagram**

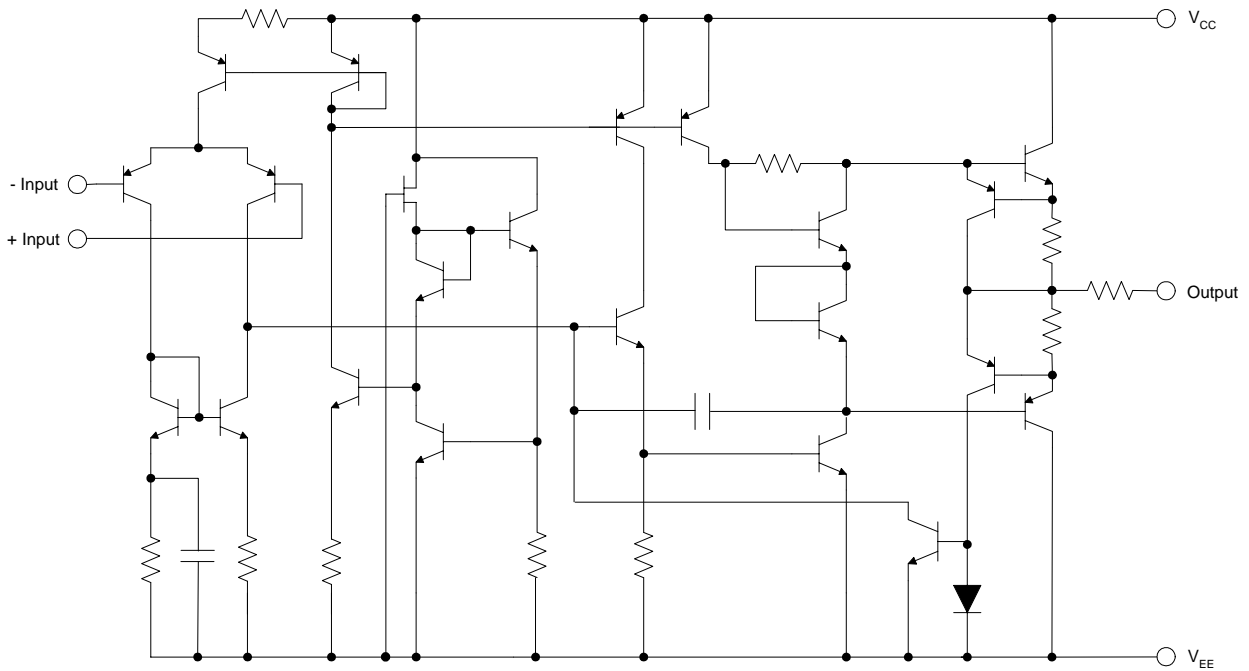

Figure 3. Functional Block Diagram of AZ4558C (Each Amplifier)



**DUAL BIPOLAR OPERATIONAL AMPLIFIERS**

**AZ4558C**

**Ordering Information**

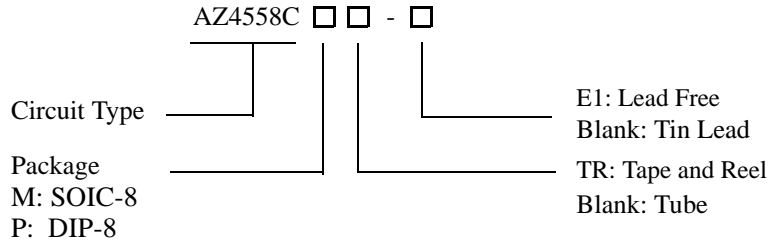

Package	Temperature Range	Part Number		Marking ID		Packing Type
		Tin Lead	Lead Free	Tin Lead	Lead Free	
SOIC-8	-40 to 85°C	AZ4558CM	AZ4558CM-E1	4558CM	4558CM-E1	Tube
		AZ4558CMTR	AZ4558CMTR-E1	4558CM	4558CM-E1	Tape & Reel
DIP-8	-40 to 85°C	AZ4558CP	AZ4558CP-E1	AZ4558CP	AZ4558CP-E1	Tube

BCD Semiconductor's Pb-free products, as designated with "E1" suffix in the part number, are RoHS compliant.

**Absolute Maximum Ratings (Note 1)**

Parameter	Symbol	Value	Unit
Supply Voltage	$V_{CC}$	+20	V
	$V_{EE}$	-20	
Input Voltage	$V_I$	±15	V
Differential Input Voltage	$V_{ID}$	±30	V
Operating Junction Temperature	$T_J$	150	°C
Storage Temperature Range	$T_{STG}$	-65 to 150	°C
Lead Temperature (Soldering 10s)	$T_L$	260	°C
Power Dissipation	$P_D$	DIP	800 mW
		SOIC	500 mW

Note 1: Stresses greater than those listed under "Absolute Maximum Ratings" may cause permanent damage to the device. These are stress ratings only, and functional operation of the device at these or any other conditions beyond those indicated under "Recommended Operating Conditions" is not implied. Exposure to "Absolute Maximum Ratings" for extended periods may affect device reliability.

**Recommended Operating Conditions**

Parameter	Min	Max	Unit
Supply Voltage	±2	±18	V
Operating Temperature Range	-40	85	°C



**DUAL BIPOLAR OPERATIONAL AMPLIFIERS**

**AZ4558C**

**Electrical Characteristics**

Operating Conditions:  $V_{CC}=+15V$ ,  $V_{EE}=-15V$ ,  $T_A=25^{\circ}C$ , unless otherwise specified.

Parameter	Symbol	Conditions	Min	Typ	Max	Unit
Input Offset Voltage	$V_{IO}$			1	5	mV
Input Offset Current	$I_{IO}$	$V_{CM}=0V$		10	100	nA
Input Bias Current	$I_{IB}$	$V_{CM}=0V$		70	400	nA
Large Signal Voltage Gain	$A_{VD}$	$R_L=2K\Omega$ , $V_O=\pm 10V$	85	100		dB
Supply Voltage Rejection Ratio	SVR	$R_S \leq 10K\Omega$	80	100		dB
Supply Current	$I_{CC}$	All Amplifiers, No Load		2.5	4.5	mA
Input Common Mode Voltage Range	$V_{ICM}$		$\pm 12$			V
Common Mode Rejection Ratio	CMRR	$R_S \leq 10K\Omega$	70	95		dB
Output Voltage Swing	$V_O$	$R_L \geq 10K\Omega$	$\pm 12$	$\pm 14$		V
		$R_L \geq 2K\Omega$	$\pm 10$	$\pm 13$		
Slew Rate	SR	$V_I = \pm 10V$ , $R_L = 2K\Omega$ , $C_L = 100pF$ , unity gain		1.8		V/ $\mu s$
Rise Time	$T_R$	$V_I = \pm 20mV$ , $R_L = 2K\Omega$ , $C_L = 100pF$ , unity gain		0.3		$\mu s$
Overshoot	$K_{OV}$	$V_I = \pm 20mV$ , $R_L = 2K\Omega$ , $C_L = 100pF$ , unity gain		15		%
Input Resistance	$R_I$			0.5		M $\Omega$
Output Resistance	$R_O$			45		$\Omega$
Unity Gain Bandwidth	B	Gain=0dB		2.8		MHz
Gain Bandwidth Product	GBWP	$V_I = \pm 10mV$ , $R_L = 2K\Omega$ , $C_L = 100pF$ , $f = 10KHz$		5.5		MHz
Total Harmonic Distortion Plus Noise	THD+N	$f = 1KHz$ , $A_V = 6dB$ , $R_L = 10K\Omega$ , $V_O = 1V_{RMS}$		0.002		%
Equivalent Input Noise Voltage Density	$e_N$	$R_S = 100\Omega$ , $f = 1KHz$		10		$\frac{nV}{\sqrt{Hz}}$
Output Current	$I_{SINK}$	$V_- = 1V$ , $V_+ = 0V$ , $V_O = 2V$		60		mA
	$I_{SOURCE}$	$V_+ = 1V$ , $V_- = 0V$ , $V_O = 2V$		35		



DUAL BIPOLAR OPERATIONAL AMPLIFIERS

AZ4558C

Typical Performance Characteristics

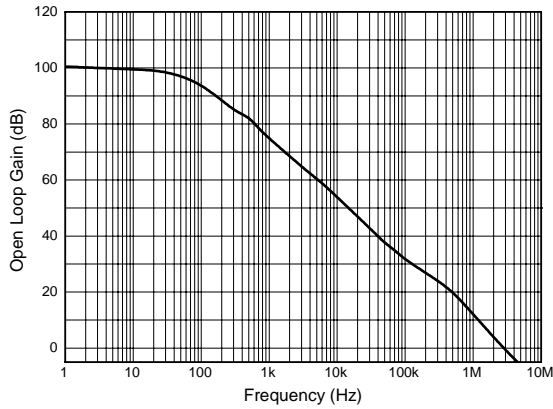

Figure 4. Open Loop Voltage Gain vs. Frequency

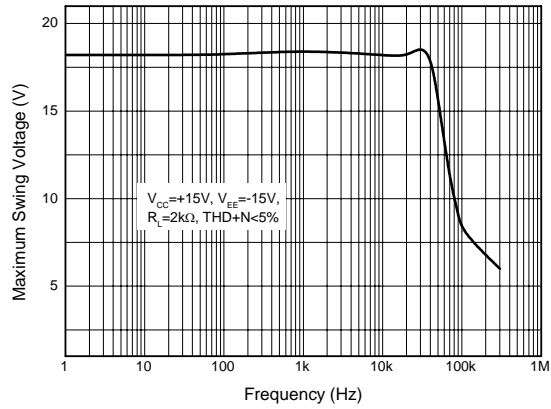

Figure 5. Maximum Output Voltage Swing vs. Frequency

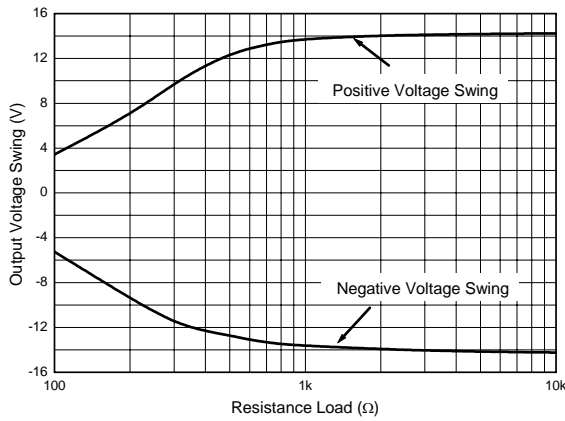

Figure 6. Maximum Output Voltage Swing vs. Load Resistance

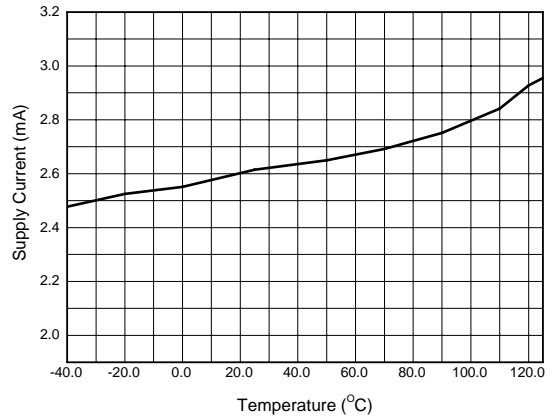

Figure 7. Supply Current vs. Temperature



**DUAL BIPOLAR OPERATIONAL AMPLIFIERS**

**AZ4558C**

**Typical Performance Characteristics (Continued)**

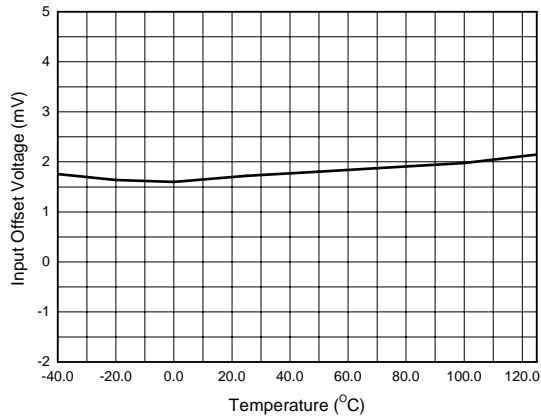

Figure 8. Input Offset Voltage vs. Temperature

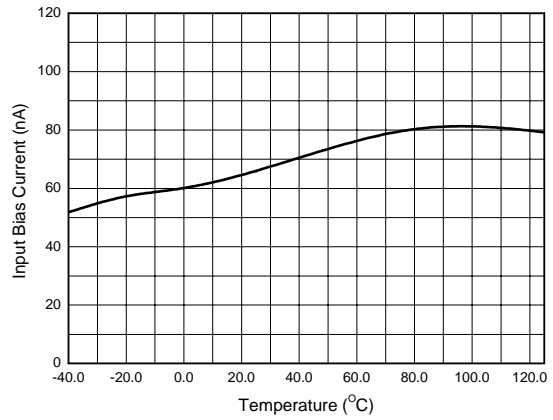

Figure 9. Input Bias Current vs. Temperature



**DUAL BIPOLAR OPERATIONAL AMPLIFIERS**

**AZ4558C**

**Typical Application**

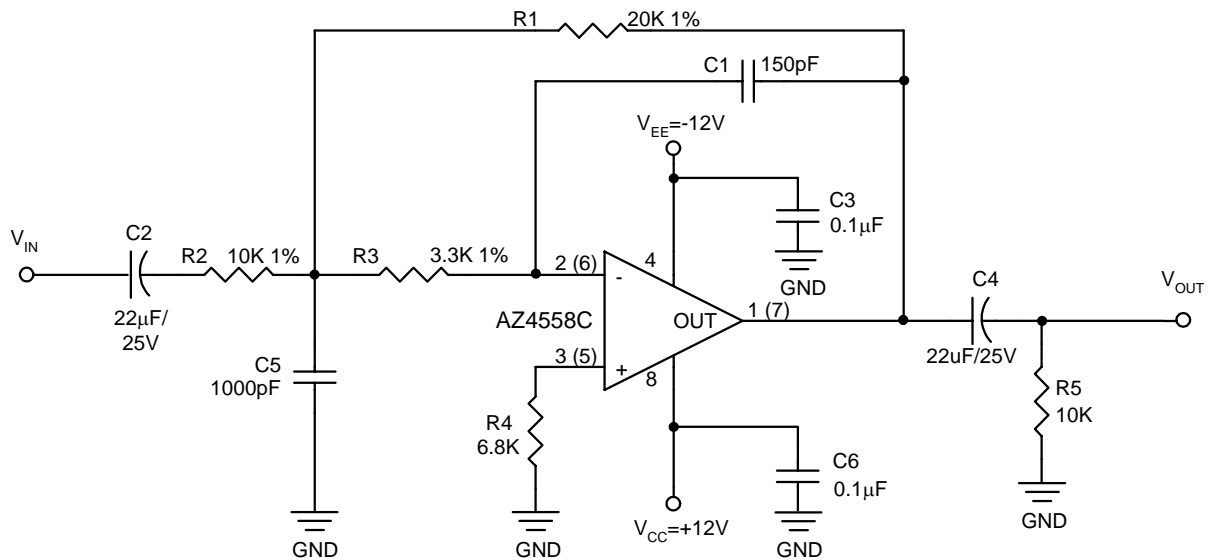

Figure 10. Typical Application of AZ4558C in Audio 2nd Order Low Pass Filter  
( $f_o=50.6\text{kHz}$ ,  $Q=0.7015$ , Input impedance=10K, Gain=6dB, Group delay=4.48µs)



**DUAL BIPOLAR OPERATIONAL AMPLIFIERS**

**AZ4558C**

**Mechanical Dimensions**

**DIP-8**

**Unit: mm(inch)**

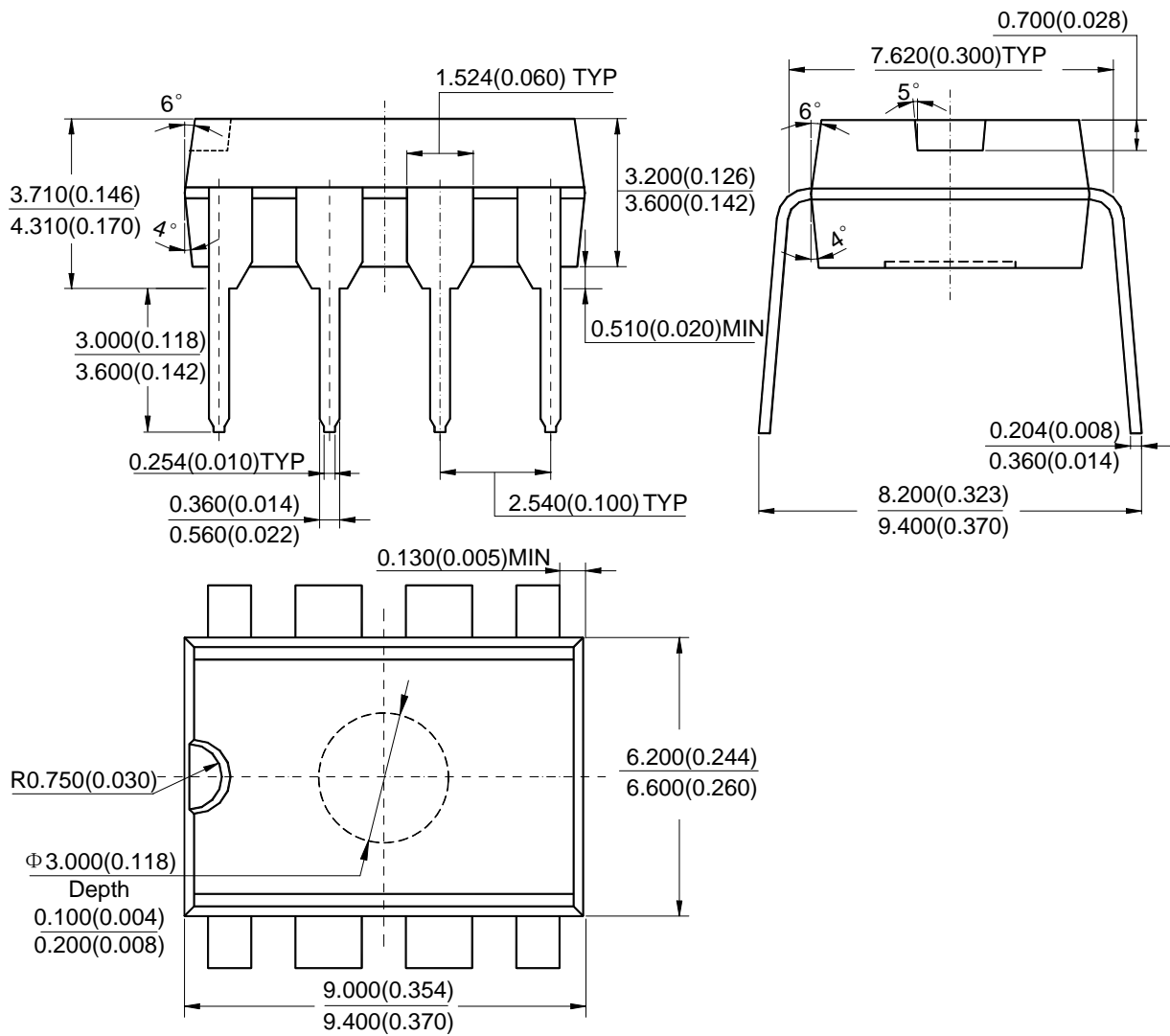





**DUAL BIPOLAR OPERATIONAL AMPLIFIERS**

**AZ4558C**

**Mechanical Dimensions (Continued)**

**SOIC-8**

**Unit: mm(inch)**

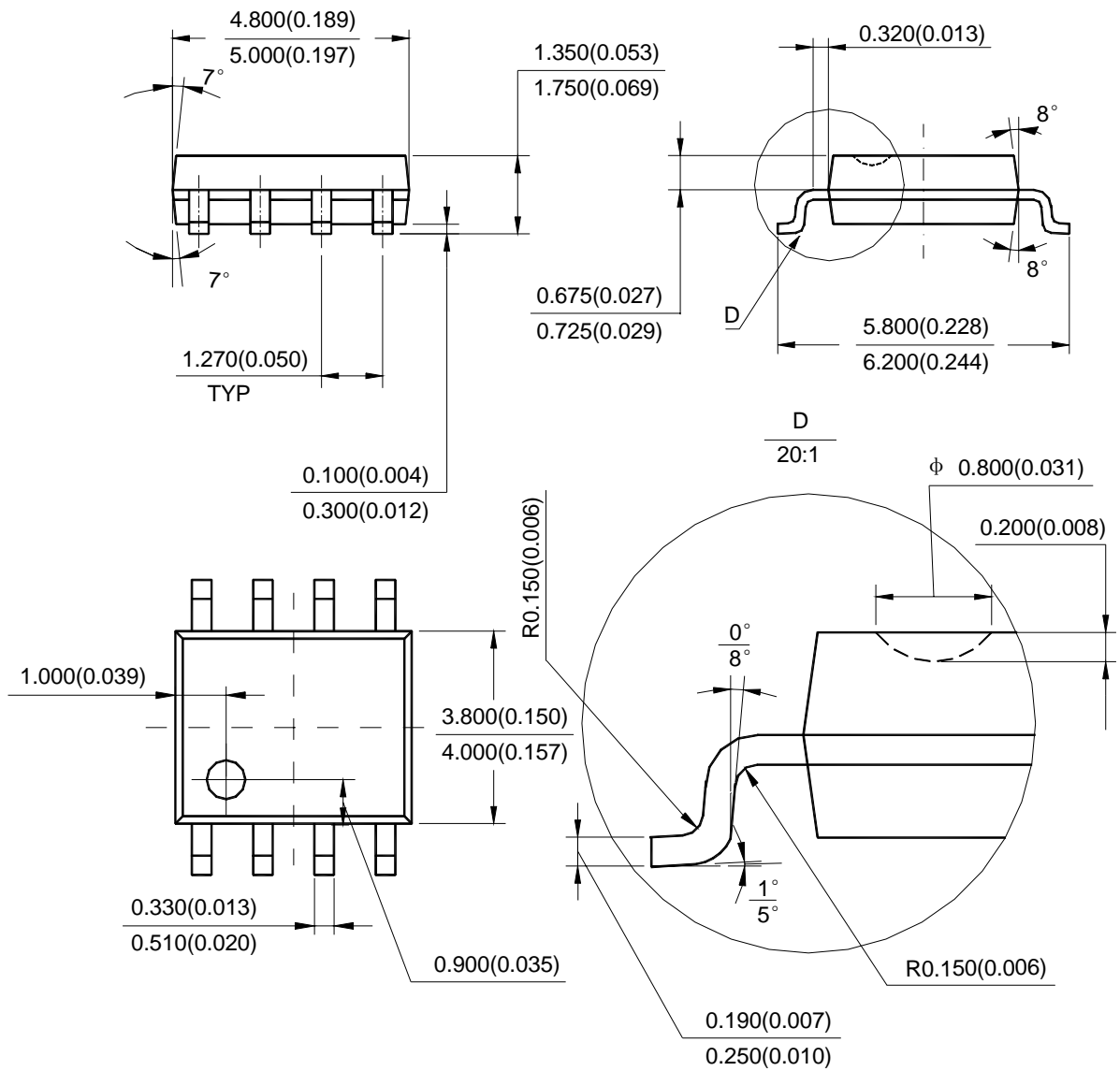



BCD Semiconductor Manufacturing Limited

<http://www.bcdsemi.com>

### IMPORTANT NOTICE

BCD Semiconductor Manufacturing Limited reserves the right to make changes without further notice to any products or specifications herein. BCD Semiconductor Manufacturing Limited does not assume any responsibility for use of any its products for any particular purpose, nor does BCD Semiconductor Manufacturing Limited assume any liability arising out of the application or use of any its products or circuits. BCD Semiconductor Manufacturing Limited does not convey any license under its patent rights or other rights nor the rights of others.

---

#### MAIN SITE

**BCD Semiconductor Manufacturing Limited**  
- Wafer Fab  
Shanghai SIM-BCD Semiconductor Manufacturing Limited  
800, Yi Shan Road, Shanghai 200233, China  
Tel: +86-21-6485 1491, Fax: +86-21-5450 0008

**BCD Semiconductor Manufacturing Limited**  
- IC Design Group  
Advanced Analog Circuits (Shanghai) Corporation  
8F, Zone B, 900, Yi Shan Road, Shanghai 200233, China  
Tel: +86-21-6495 9539, Fax: +86-21-6485 9673

#### REGIONAL SALES OFFICE

**Shenzhen Office**  
Shanghai SIM-BCD Semiconductor Manufacturing Co., Ltd. Shenzhen Office  
Advanced Analog Circuits (Shanghai) Corporation Shenzhen Office  
27B, Tower C, 2070, Middle Shen Nan Road, Shenzhen 518031, China  
Tel: +86-755-8368 3987, Fax: +86-755-8368 3166

**Taiwan Office**  
BCD Semiconductor (Taiwan) Company Limited  
4F, 298-1, Rui Guang Road, Nei-Hu District, Taipei,  
Taiwan  
Tel: +886-2-2656 2808, Fax: +886-2-2656 2806

**USA Office**  
BCD Semiconductor Corporation  
3170 De La Cruz Blvd., Suite 105, Santa Clara,  
CA 95054-2411, U.S.A  
Tel: +1-408-988 6388, Fax: +1-408-988 6386