



Capacitors for Power Electronics

Series/Type: **B25667A**

The following products presented in this data sheet are being withdrawn.

Ordering Code	Substitute Product	Date of Withdrawal	Deadline Last Orders	Last Shipments
B25667A5347J375	B25667B5347A375	2004-09-10		

For further information please contact your nearest EPCOS sales office, which will also support you in selecting a suitable substitute. The addresses of our worldwide sales network are presented at www.epcos.com/sales.



PhaseCap™
B25667-A5347-J375
MKK525-D-30-01

Characteristics

C_N	3 x 115,5 μ F
Tol.	+ / - 5 %
Connection	D (Delta)
U_N	525 Vac
f_N	50 Hz
Q_N	30 kVAr
I_N	33 A
$\tan\delta_o$	0.2 W/kVAr

Maximum ratings

U_{MAX} (up to 8h daily)	580 Vac
U_{MAX} (up to 1 min)	680 Vac
I_{MAX}	1.3 x I_N A
I_S	200 x I_N A

Test data

U_{TT}	1150 Vac	50Hz	10s
U_{TC}	3000 Vac	50Hz	10s

$\tan\delta$ (50 Hz) \leq	0,6 W/kVAr
-----------------------------	------------

Climatic category -40/C

T_{min}	-	40 °C
T_{max}	+	50 °C
humidity	av. rel.	< 95 %
max.altitude		4000 m

Mean life expectancy

t_{LD} up to 100000 h
 5000 switchings per year according to IEC831

Reference Standards

IEC 60831-1/2, EN 60831-1/2
 VDE 560-46/47

Remarks

Natural cooling

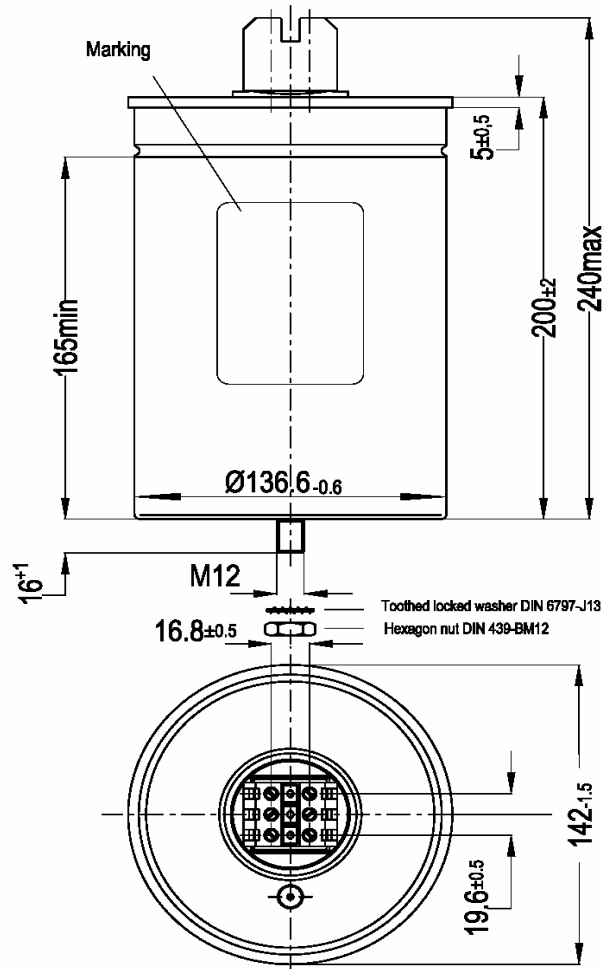

All dimensions in mm

Design data

Dimensions (Φ x l):	142 x 200 mm
Approximated Weight:	2,4 Kg
Impregnation:	Dry, Inert Gas
Fixing:	Threaded bolt M12
Mounting hole:	14 Nm
Max.Torque (Al can stud):	10 Nm
Terminals:	Isolated terminal, IP20
Max.Torque (Terminals):	1.2 Nm
Terminal cross section:	16mm ² (5 AWG)
Maximum terminal current:	75 A
Creepage distance:	12.7 mm
Clearance:	9.6 mm
Overpressure disconnecter:	(AFC: 10kA)
Any mounting position possible	

The information in our data book / sheet describes the type of component and shall not be considered as assured characteristics. This edition replaces the previous one.