

Structure : Silicon Monolithic Integrated Circuit  
 Product Name : Power Driver For DVD Players

Device Name : **BA5956FM**

- Features :
- 2CHs for current driving-type BTL drivers to drive two-axis actuators  
 1CH for a voltage driving-type BTL driver for a feed motor  
 1CH for a voltage driving-type BTL driver for a loading motor  
 1CH for a voltage driving-type BTL driver for a spindle motor
  - Use of the HSOP-M36 power package achieves downsizing of the set.
  - A wide dynamic range
  - A built-in thermal shutdown circuit installed.
  - A built-in mute circuit installed. (This circuit can mute the outputs of the drivers except for those for loading motors.)
  - The power supplies for PreVcc, the actuator part, the loading part, and PowVcc of the feed motor part/spindle motor part are provided independently to achieve an efficient drive.

○ ABSOLUTE MAXIMUM RATINGS (Ta=25°C)

Parameter	Symbol	Limits	Unit
Power Supply Voltage	PreVcc , PowVcc	18	V
Power Dissipation	Pd	2.2 <sup>*1</sup>	W
Maximum Output Current	Iomax	1 <sup>*2</sup>	A
Operating Temperature Range	Topr	-35 to 85	°C
Storage Temperature Range	Tstg	-55 to 150	°C

\*1 When mounted on the glass/epoxy board with the size: 70 mm×70 mm, the thickness: 1.6 mm, and the rate of copper foil occupancy area: 3% or less.

Over Ta=25°C, derating at the rate of 17.6mW/°C.

\*2 The power dissipation should be specified within the ASO range.

○ RECOMMENDED OPERATING CONDITIONS

(To determine a power supply voltage, the power dissipation must be taken into consideration.)

PreVcc	4.5 to 14 (V)
PowVcc	4.5 to PreVcc (V)

This product has not been checked for the strategic materials (or service) defined in the Foreign Exchange and Foreign Trade Control Law of Japan so that a verification work is required before exporting it.

Not designed for radiation resistance.

- ELECTRIC CHARACTERISTICS (Ta=25°C, PreVcc=PowVcc3=12V, PowVcc1=PowVcc2=5V, BIAS=1.65V, R<sub>L</sub>=8Ω, R<sub>d</sub>=0.5Ω, C=100pF, unless otherwise noted.)

Parameter	Symbol	MIN	TYP	MAX	Unit	Condition
Consumption Current (at no signal)	I <sub>Q</sub>	-	34	44	mA	No load applied
Mute ON Voltage	V <sub>MON</sub>	0	-	0.5	V	
Mute OFF Voltage	V <sub>MOFF</sub>	2.0	-	-	V	
<Actuator Driver>						
Output Offset Current	I <sub>OOF</sub>	-6	0	6	mA	
Maximum Output Amplitude	V <sub>OM</sub>	3.6	4.0	-	V	V <sub>IN</sub> =±1.65V
Transfer Gain	G <sub>vc</sub>	1.5	1.8	2.1	A/V	V <sub>IN</sub> =BIAS±0.2V
<Feed Motor Driver>						
Input Op-amp Common Mode Input Range	V <sub>ICM</sub>	0.5	-	10.5	V	
Input Bias Current	I <sub>BOP</sub>	-	-	300	nA	
Low-level Output Voltage	V <sub>OLOP</sub>	-	0.2	0.5	V	
Maximum Output Source Current	I <sub>SO</sub>	0.5	-	-	mA	
Maximum Output Sink Current	I <sub>SI</sub>	0.5	-	-	mA	
Output Offset Voltage	V <sub>OOFSL</sub>	-50	0	50	mV	
Maximum Output Amplitude	V <sub>OMSL</sub>	8.0	9.5	-	V	V <sub>IN</sub> =±1.65V
Closed Circuit Voltage Gain	G <sub>VSL</sub>	17.6	19.6	21.6	dB	V <sub>IN</sub> =±0.2V
<Loading Driver>						
Offset Voltage	V <sub>OOFLD</sub>	-50	0	50	mV	
Maximum Output Amplitude	V <sub>OMLD</sub>	3.5	4.0	-	V	V <sub>IN</sub> =±1.65V
Voltage Gain	G <sub>VLD</sub>	15.7	17.7	19.7	dB	V <sub>IN</sub> =BIAS±0.2V
<Spindle Driver>						
Offset Voltage	V <sub>OOFSP</sub>	-50	0	50	mV	
Maximum Output Amplitude	V <sub>OMS</sub>	8.0	9.5	-	V	V <sub>IN</sub> =±1.65V
Voltage Gain	G <sub>VSP</sub>	15.7	17.7	19.7	dB	V <sub>IN</sub> =BIAS±0.2V

○ OUTLINE DIMENSIONS, SYMBOLS

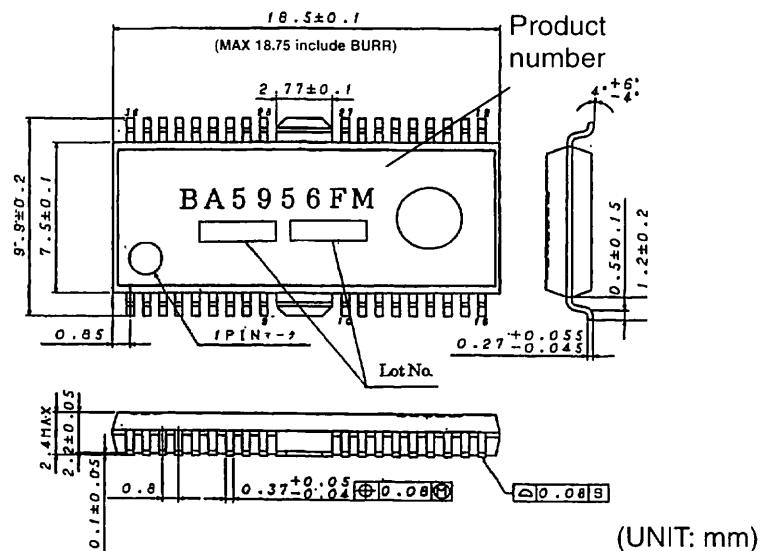

○ APPLICATION CIRCUIT DIAGRAM

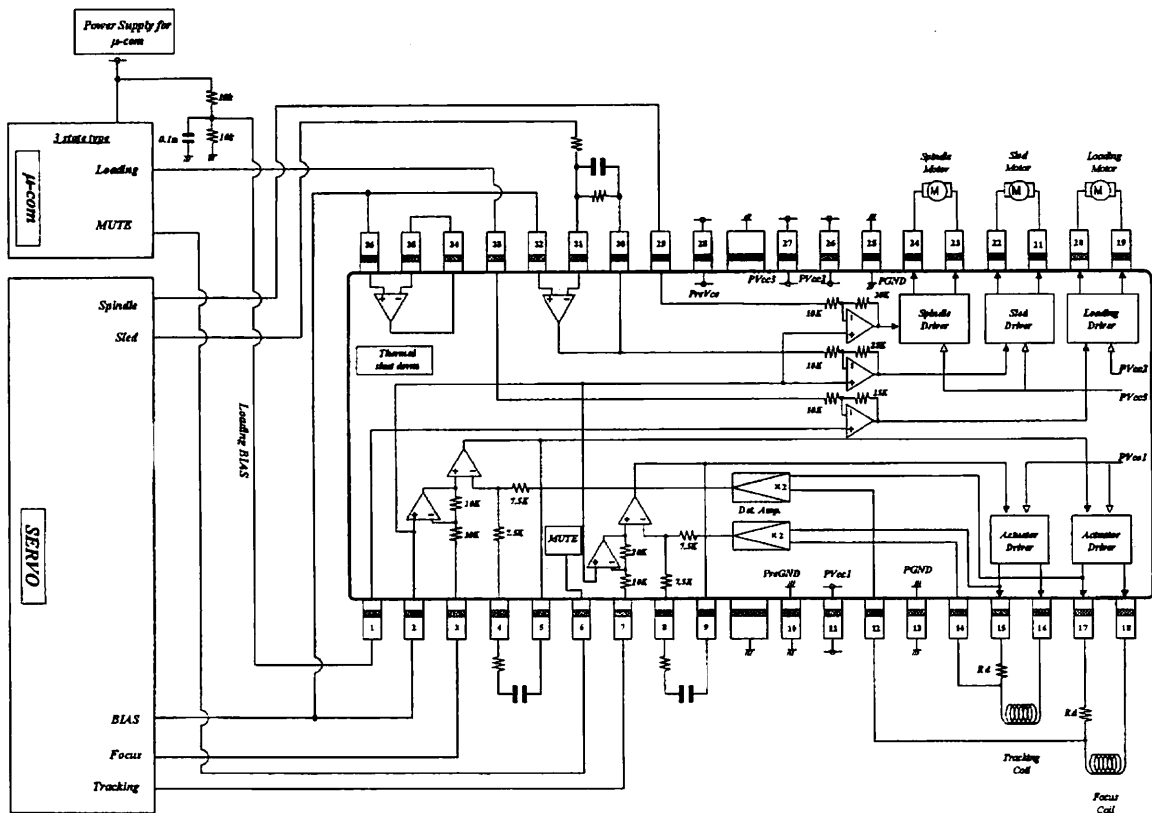

Resistance unit: [ $\Omega$ ]

○ PIN NUMBERS, PIN NAMES

No	Pin Name	Description	No	Pin Name	Description
1	LDBIAS	Loading unit bias input	19	VOLD(-)	Loading driver output (-)
2	BIAS	Bias input	20	VOLD(+)	Loading driver output (+)
3	FCIN	Focus driver input	21	VOSL(-)	Sled driver output (-)
4	CFCerr1	Capacitor connection terminal 1 for error amp filter	22	VOSL(+)	Sled driver output (+)
5	CFCerr2	Capacitor connection terminal 2 for error amp filter	23	VOSP(-)	Spindle driver output (-)
6	MUTE	Mute terminal	24	VOSP(+)	Spindle driver output (+)
7	TKIN	Tracking driver input	25	PGND2	Power GND2
8	CTKerr1	Capacitor connection terminal 1 for error amp filter	26	PVcc2	Power Vcc2
9	CTKerr2	Capacitor connection terminal 2 for error amp filter	27	PVcc3	Power Vcc3
10	PreGND	Pre GND	28	PreVcc	Pre Vcc
11	PVcc1	Power Vcc1	29	SPIN	Spindle driver input
12	VNFFC	Focus driver feedback terminal	30	OPOUTSL	Sled pre-stage amp output terminal
13	PGND1	Power GND1	31	OPINSL(-)	Sled pre-stage amp inverted input terminal
14	VNFTK	Tracking driver feedback terminal	32	OPINSL(+)	Sled pre-stage amp non-inverted input terminal
15	VOTK(-)	Tracking driver output (-)	33	LDIN	Loading driver input
16	VOTK(+)	Tracking driver output (+)	34	OPOUT	OP-amp output terminal
17	VOFC(-)	Focus driver output (-)	35	OPIN(-)	OP-amp inverted input terminal
18	VOFC(+)	Focus driver output (+)	36	OPIN(+)	OP-amp non-inverted input terminal

Notes: The polarity signs shown in the output terminal names indicate the polarities when corresponding input pins are set to (+).

○ CAUTIONS ON USE

- (1) Setting the voltage on the Mute terminal to open or 0.5V or less will activate a mute function for the CH1, 2, 4, and 5.  
Under conditions of normal use, the Mute terminal should be pulled-up to 2.0V or above.
- (2) When the power supply voltage drops to 3.5V (Typ.) or less, the mute function will be activated and, when recovering to 3.7V (Typ.) or above, the circuit will startup again.
- (3) On the Bias terminal (pin 1, 2), the applied voltage of 1.0V (Typ.) or less will activate a mute function. Under conditions of normal use, it should be set to 1.2V or above.
- (4) Connecting a capacitive load to the OP-AMP output results in a phase margin reduction of the amp and may cause an oscillation or a peak. When connecting a capacitive load, a resistance must be inserted in series between the output and the capacitive load. And after careful consideration of the frequency characteristics, the device should be used within the range where no problem is found in actual use.
- (5) The radiating fin must be connected to the external GND.
- (6) Short-circuit between output pin -VCC (supply fault), output pin-GND (ground fault), or output terminals (load short) must be avoided. Placing ICs in wrong orientations may damage the ICs or produce smoke.
- (7) Basically, applying a voltage below the IC sub-potential to any terminals must be avoided. Due to a counter electromotive force of the load, if the output on each driver has dropped to the IC sub-potential (GND) or less, an operation margin must be considered and examined.
- (8) About absolute maximum ratings  
Exceeding the absolute maximum ratings, such as the applied voltage or the operating temperature range, may cause permanent device damage. As these cases cannot be limited to the broken short mode or the open mode, if a special mode where the absolute maximum ratings may be exceeded is assumed, it is recommended to take mechanical safety measures such as attaching fuses.
- (9) About power supply lines  
As a measure against the back current regenerated by a counter electromotive force of the motor, a capacitor to be used as a regenerated-current path can be installed between the power supply and GND and its capacitance value should be determined after careful check that any problems, for example, a leak capacitance of the electrolytic capacitor at low temperature, are not found in various characteristics.
- (10) About GND potential  
The electric potential of the GND terminal must be kept lowest in the circuitry at any operation states.
- (11) About thermal design  
With consideration of the power dissipation (Pd) under conditions of actual use, a thermal design provided with an enough margin should be done.
- (12) About operations in a strong electric field  
When used in a strong electric field, note that a malfunction may occur.
- (13) ASO  
When using this IC, the output Tr must be set not to exceed the values specified in the absolute maximum ratings and ASO.
- (14) Thermal shutdown circuit  
This IC incorporates a thermal shutdown circuit (TSD circuit). When the chip temperature reaches the value shown below, the coil output to the motor will be set to open.  
The thermal shutdown circuit is designed only to shut off the IC from a thermal runaway and not intended to protect or guarantee the entire IC functions.  
Therefore, users cannot assume that the TSD circuit once activated can be used continuously in the subsequent operations.

TSD ON Temperature [°C] (typ.)	Hysteresis Temperature [°C] (typ.)
175	25

- (15) About earth wiring patterns  
When a small signal GND and a large current GND are provided, it is recommended that the large current GND pattern and the small signal GND pattern should be separated and grounded at a single point of the reference point of the set in order to prevent the voltage of the small signal GND from being

affected by a voltage change caused by the resistance of the pattern wiring and the large current. Make sure that the GND wiring patterns of the external components will not change, too.

- (16) This IC is a monolithic IC which has a P<sup>+</sup> isolations and P substrate to isolate elements each other. This P layer and an N layer in each element form a PN junction to construct various parasitic elements. Due to the IC structure, the parasitic elements are inevitably created by the potential relationship. Activation of the parasitic elements can cause interference between circuits and may result in a malfunction or, consequently, a fatal damage. Therefore, make sure that the IC must not be used under conditions that may activate the parasitic elements, for example, applying the lower voltage than the ground level (GND, P substrate) to the input terminals. In addition, do not apply the voltage to input terminals without applying the power supply voltage to the IC. Also while applying the power supply voltage, the voltage of each input terminal must not be over the power supply voltage, or within the guaranteed values in the electric characteristics.

<Supplemental Remarks>

Current feedback driver

The transfer gain (output current / input current) can be determined by the following equation:

$$g_m = \frac{1}{R_d + R_{WIRE}} \quad (A/V)$$

Where  $R_{WIRE}$  represents a gold wire resistance inside the package, measuring approximately  $0.075\Omega$  ( $\pm 0.05\Omega$ ) (Typ.)

### Notes

- No technical content pages of this document may be reproduced in any form or transmitted by any means without prior permission of ROHM CO.,LTD.
- The contents described herein are subject to change without notice. The specifications for the product described in this document are for reference only. Upon actual use, therefore, please request that specifications to be separately delivered.
- Application circuit diagrams and circuit constants contained herein are shown as examples of standard use and operation. Please pay careful attention to the peripheral conditions when designing circuits and deciding upon circuit constants in the set.
- Any data, including, but not limited to application circuit diagrams information, described herein are intended only as illustrations of such devices and not as the specifications for such devices. ROHM CO.,LTD. disclaims any warranty that any use of such devices shall be free from infringement of any third party's intellectual property rights or other proprietary rights, and further, assumes no liability of whatsoever nature in the event of any such infringement, or arising from or connected with or related to the use of such devices.
- Upon the sale of any such devices, other than for buyer's right to use such devices itself, resell or otherwise dispose of the same, no express or implied right or license to practice or commercially exploit any intellectual property rights or other proprietary rights owned or controlled by
- ROHM CO., LTD. is granted to any such buyer.
- Products listed in this document are no antiradiation design.

The products listed in this document are designed to be used with ordinary electronic equipment or devices (such as audio visual equipment, office-automation equipment, communications devices, electrical appliances and electronic toys).

Should you intend to use these products with equipment or devices which require an extremely high level of reliability and the malfunction of which would directly endanger human life (such as medical instruments, transportation equipment, aerospace machinery, nuclear-reactor controllers, fuel controllers and other safety devices), please be sure to consult with our sales representative in advance.

#### About Export Control Order in Japan

Products described herein are the objects of controlled goods in Annex 1 (Item 16) of Export Trade Control Order in Japan.

In case of export from Japan, please confirm if it applies to "objective" criteria or an "informed" (by MITI clause) on the basis of "catch all controls for Non-Proliferation of Weapons of Mass Destruction.

Thank you for your accessing to ROHM product informations.  
More detail product informations and catalogs are available,  
please contact your nearest sales office.

Please contact our sales offices for details ;

U.S.A / San Diego	TEL : +1(858)625-3630	FAX : +1(858)625-3670
Atlanta	TEL : +1(770)754-5972	FAX : +1(770)754-0691
Dallas	TEL : +1(972)312-8818	FAX : +1(972)312-0330
Germany / Dusseldorf	TEL : +49(2154)9210	FAX : +49(2154)921400
United Kingdom / London	TEL : +44(1)908-282-666	FAX : +44(1)908-282-528
France / Paris	TEL : +33(0)1 56 97 30 60	FAX : +33(0) 1 56 97 30 80
China / Hong Kong	TEL : +852(2)740-6262	FAX : +852(2)375-8971
Shanghai	TEL : +86(21)6279-2727	FAX : +86(21)6247-2066
Dilian	TEL : +86(411)8230-8549	FAX : +86(411)8230-8537
Beijing	TEL : +86(10)8525-2483	FAX : +86(10)8525-2489
Taiwan / Taipei	TEL : +866(2)2500-6956	FAX : +866(2)2503-2869
Korea / Seoul	TEL : +82(2)8182-700	FAX : +82(2)8182-715
Singapore	TEL : +65-6332-2322	FAX : +65-6332-5662
Malaysia / Kuala Lumpur	TEL : +60(3)7958-8355	FAX : +60(3)7958-8377
Philippines / Manila	TEL : +63(2)807-6872	FAX : +63(2)809-1422
Thailand / Bangkok	TEL : +66(2)254-4890	FAX : +66(2)256-6334

Japan /  
(Internal Sales)

Tokyo	2-1-1, Yaesu, Chuo-ku, Tokyo 104-0082	TEL : +81(3)5203-0321	FAX : +81(3)5203-0300
Yokohama	2-4-8, Shin Yokohama, Kohoku-ku, Yokohama, Kanagawa 222-8575	TEL : +81(45)476-2131	FAX : +81(45)476-2128
Nagoya	Dainagayo Building 9F 3-28-12, Meieki, Nakamura-ku, Nagoya, Aichi 450-0002	TEL : +81(52)581-8521	FAX : +81(52)561-2173
Kyoto	579-32 Higashi Shiokouji-cho, Karasuma Nishi-iru, Shiokoujidori, Shimogyo-ku, Kyoto 600-8216	TEL : +81(75)311-2121	FAX : +81(75)314-6559

(Contact address for overseas customers in Japan)

Yokohama	TEL : +81(45)476-9270	FAX : +81(045)476-9271
----------	-----------------------	------------------------