

STRUCTURE                      Silicon Monolithic Integrated Circuit

PRODUCT SERIES              2-Phase Half-Wave Motor Driver for Fan Motor

TYPE                              B A 6 8 1 3 F

FEATURES                        Built - in reverse current protection diode

○ABSOLUTE MAXIMUM RATINGS

Parameter	Symbol	Limit	Unit
Supply voltage	Vcc	18	V
Power dissipation	Pd	780*	mW
Operating temperature	Topr	-35~+85	°C
Storage temperature	Tstg	-55~+150	°C
Output current	Iomax	1.0* *	A
FG signal output current	IFG	11	mA
FG signal output voltage	VFG	36	V
Junction temperature	Tjmax	150	°C

\* To use at temperature above Ta=25°C reduce 6.24mW/°C.  
(On 50.0mm × 50.0mm × 1.6mm glass epoxy board)

\* \* This value is not to be over Pd.

○OPERATING CONDITIONS

Parameter	Symbol	Limit	Unit
Operating supply voltage range	Vcc	4.0~15.0	V
Hall input voltage range	VH	0~Vcc-2.8	V

\* This product is not designed for production against radioactive rays.

\* This document may be strategic data subject to COCOM regulations.

Status of this document

The Japanese version of this document is the formal specification.

A customer may use this translation version only for a reference to help reading the formal version.

If there are any differences in translation version of this document formal version takes priority.

Application example

- ROHM cannot provide adequate confirmation of patents.
- The product described in this specification is designed to be used with ordinary electronic equipment or devices (such as audio-visual equipment, office-automation equipment, communications devices, electrical appliances, and electronic toys).  
Should you intend to use this product with equipment or devices which require an extremely high level of reliability and the malfunction of which would directly endanger human life (such as medical instruments, transportation equipment, aerospace machinery, nuclear-reactor controllers, fuel controllers and other safety devices), please be sure to consult with our sales representative in advance.
- ROHM assumes no responsibility for use of any circuits described herein, conveys no license under any patent or other right, and makes no representations that the circuits are free from patent infringement.

○ELECTRICAL CHARACTERISTICS (Unless otherwise specified Ta=25°C,Vcc=12V)

Parameter	Symbol	Limit			Unit	Conditions
		Min.	Typ.	Max.		
Supply current	I <sub>cc</sub>	1.0	3.4	5.0	mA	At output OFF
Charge current of capacitor for lock detection	I <sub>LDC</sub>	1.60	2.90	4.21	μA	V <sub>LD</sub> =1.2V
Discharge current of capacitor for lock detection	I <sub>LDD</sub>	0.27	0.28	0.70	μA	V <sub>LD</sub> =1.2V
Charge-discharge current ratio of capacitor for lock detection	r <sub>CD</sub>	3.0	6.0	9.0	-	r <sub>CD</sub> =I <sub>LDC</sub> /I <sub>LDD</sub>
Clamp voltage of capacitor for lock detection	V <sub>LDCL</sub>	1.24	1.90	2.57	V	
Comparison voltage of capacitor for lock detection	V <sub>LDLCP</sub>	0.48	0.75	1.01	V	
Output voltage L	V <sub>OL</sub>	-	0.8	1.3	V	I <sub>o</sub> =200mA
Output leak current	I <sub>OL</sub>	-	-	100	μA	V <sub>O</sub> =20V
Output zenner voltage	V <sub>OZ</sub>	28	30	32	V	Clamp current=10mA
FG terminal voltage L	V <sub>FGL</sub>	-	0.13	0.3	V	I <sub>FG</sub> =10mA
FG terminal leak current supply current	I <sub>FGL</sub>	-	-	50	μA	V <sub>FG</sub> =15V
Hall input offset voltage	V <sub>OFF</sub>	-	-	10	mV	

○PACKAGE OUTLINES

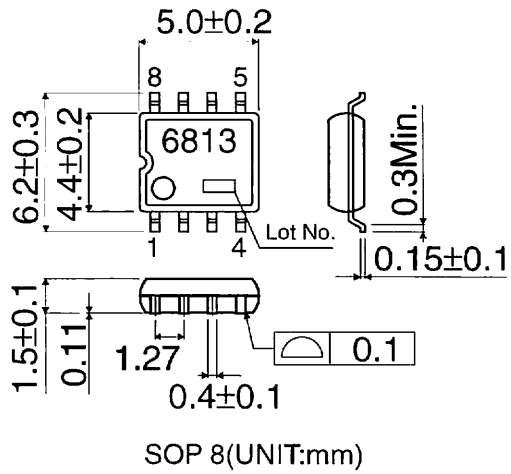

○BLOCK DIAGRAM

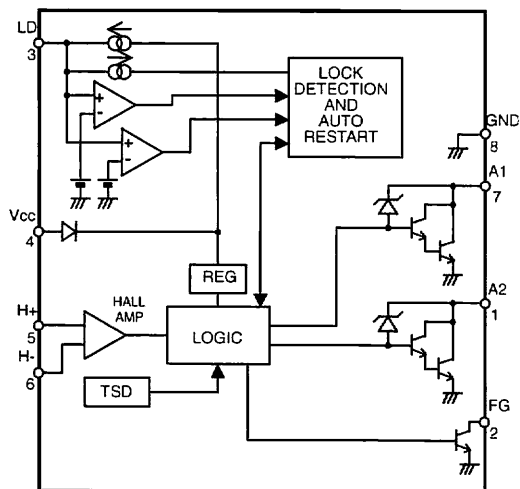

○Terminal name

Pin No.	Terminal name
1	A2
2	FG
3	LD
4	Vcc
5	H+
6	H-
7	A1
8	GND

## ○CAUTIONS

## 1) Absolute maximum ratings

There is possibility of destruction in using beyond the absolute maximum rating. In case of destruction, a failure mode can not be defined (short mode or open mode). Therefore when special mode is envisaged where absolute maximum rating may be exceeded, please take a physical safety measure such as fuse.

## 2) Reverse connection of power supply connector

Reverse connection of power supply connector may break IC. Take a measure against reverse connection destruction such as inserting a diode between power supply and Vcc terminal.

## 3) Power supply line

Back electromotive force causes regenerated current to power supply line, therefore take a measure such as placing a capacitor between power supply and GND for routing regenerated current, and fully ensure that the capacitor characteristics have no problem before determine a capacitor value

## 4) GND potential

Ensure that the potential of GND terminal is the minimum potential in any operating condition. Also ensure that all terminals except GND terminal do not fall below GND voltage including transient characteristics. However, it is possible that the motor output terminal may deflect below GND because of influence by back electromotive force of motor. Malfunction may possibly occur depending on use condition, environment, and property of individual motor. Please make fully confirmation that no problem is found on operation of IC.

## 5) Thermal design

Consider the power dissipation under actual use condition and apply thermal design with sufficient margin.

## 6) Mounting failures

In attaching IC to printed board, pay enough attention to the direction and dislocation of IC. Mounting failures may break IC. In addition, destruction is also possible when circuit is shorted by foreign substance brought between outputs or between output and power supply - GND.

## 7) Operation in strong electromagnetic field

Use in strong electromagnetic field may cause malfunction, please be careful.

## 8) ASO

Please consider that the output Tr does not exceed the absolute maximum rating and ASO.

## 9) Thermal shut down circuit

This IC has thermal shut down (TSD) circuit. Operation temperature is 175°C(typ.) and has a hysteresis width of 25°C(typ.). When IC chip temperature rises and TSD circuit works, the output terminal becomes an open state. TSD circuit is simply for the purpose of intercepting IC from overheating, and not for protecting and assuring IC. Therefore do not continue to use IC thereafter with this circuit operating and do not use IC assuming the operation of this circuit.

## 10) Inspection with a set board

When connecting a capacitor to a pin with low impedance in inspection on a set board, stress may possibly be applied to IC, therefore be sure to apply discharging in each process. In attaching to and detaching from jigs in inspection process, be sure to turn off power before connecting, and turn off power before removing IC. In addition, apply grounding to assembling process as a measure of anti-static electricity, and use full caution in transporting and storing.

## 11) GND wiring pattern

When there are small signal GND and large current GND, separate the large current GND pattern from small signal GND pattern. It is recommended to apply one-point grounding at the reference point of the set in order that resistance of wiring pattern and large current do not cause change of voltage of small signal GND. Please be cautious not to fluctuate the wiring pattern of GND of external mounted parts.

## 12) Capacitor between output and GND

When a large capacitor is connected between output and GND, if Vcc is shorted with 0V or GND for some cause, it is possible that the current charged in the capacitor may flow into the output resulting in destruction. Keep the capacitor between output and GND below 100uF.

## 13) IC terminal input

When Vcc voltage is not applied to IC, do not apply voltage to each input terminal. When voltage above Vcc or below GND is applied to the input terminal, parasitic element is actuated due to the structure of IC. Operation of parasitic element causes mutual interference between circuits, resulting in malfunction as well as destruction in the last. Do not use in a manner where parasitic element is actuated.

### Notes

- No technical content pages of this document may be reproduced in any form or transmitted by any means without prior permission of ROHM CO.,LTD.
- The contents described herein are subject to change without notice. The specifications for the product described in this document are for reference only. Upon actual use, therefore, please request that specifications to be separately delivered.
- Application circuit diagrams and circuit constants contained herein are shown as examples of standard use and operation. Please pay careful attention to the peripheral conditions when designing circuits and deciding upon circuit constants in the set.
- Any data, including, but not limited to application circuit diagrams information, described herein are intended only as illustrations of such devices and not as the specifications for such devices. ROHM CO.,LTD. disclaims any warranty that any use of such devices shall be free from infringement of any third party's intellectual property rights or other proprietary rights, and further, assumes no liability of whatsoever nature in the event of any such infringement, or arising from or connected with or related to the use of such devices.
- Upon the sale of any such devices, other than for buyer's right to use such devices itself, resell or otherwise dispose of the same, no express or implied right or license to practice or commercially exploit any intellectual property rights or other proprietary rights owned or controlled by
- ROHM CO., LTD. is granted to any such buyer.
- Products listed in this document are no antiradiation design.

The products listed in this document are designed to be used with ordinary electronic equipment or devices (such as audio visual equipment, office-automation equipment, communications devices, electrical appliances and electronic toys).

Should you intend to use these products with equipment or devices which require an extremely high level of reliability and the malfunction of which would directly endanger human life (such as medical instruments, transportation equipment, aerospace machinery, nuclear-reactor controllers, fuel controllers and other safety devices), please be sure to consult with our sales representative in advance.

#### About Export Control Order in Japan

Products described herein are the objects of controlled goods in Annex 1 (Item 16) of Export Trade Control Order in Japan.

In case of export from Japan, please confirm if it applies to "objective" criteria or an "informed" (by MITI clause) on the basis of "catch all controls for Non-Proliferation of Weapons of Mass Destruction.

Thank you for your accessing to ROHM product informations.  
More detail product informations and catalogs are available,  
please contact your nearest sales office.

Please contact our sales offices for details ;

U.S.A / San Diego	TEL : +1(858)625-3630	FAX : +1(858)625-3670
Atlanta	TEL : +1(770)754-5972	FAX : +1(770)754-0691
Dallas	TEL : +1(972)312-8818	FAX : +1(972)312-0330
Germany / Dusseldorf	TEL : +49(2154)9210	FAX : +49(2154)921400
United Kingdom / London	TEL : +44(1)908-282-666	FAX : +44(1)908-282-528
France / Paris	TEL : +33(0)1 56 97 30 60	FAX : +33(0) 1 56 97 30 80
China / Hong Kong	TEL : +852(2)740-6262	FAX : +852(2)375-8971
Shanghai	TEL : +86(21)6279-2727	FAX : +86(21)6247-2066
Dilian	TEL : +86(411)8230-8549	FAX : +86(411)8230-8537
Beijing	TEL : +86(10)8525-2483	FAX : +86(10)8525-2489
Taiwan / Taipei	TEL : +866(2)2500-6956	FAX : +866(2)2503-2869
Korea / Seoul	TEL : +82(2)8182-700	FAX : +82(2)8182-715
Singapore	TEL : +65-6332-2322	FAX : +65-6332-5662
Malaysia / Kuala Lumpur	TEL : +60(3)7958-8355	FAX : +60(3)7958-8377
Philippines / Manila	TEL : +63(2)807-6872	FAX : +63(2)809-1422
Thailand / Bangkok	TEL : +66(2)254-4890	FAX : +66(2)256-6334

Japan /  
(Internal Sales)

Tokyo	2-1-1, Yaesu, Chuo-ku, Tokyo 104-0082	TEL : +81(3)5203-0321	FAX : +81(3)5203-0300
Yokohama	2-4-8, Shin Yokohama, Kohoku-ku, Yokohama, Kanagawa 222-8575	TEL : +81(45)476-2131	FAX : +81(45)476-2128
Nagoya	Dainagayo Building 9F 3-28-12, Meieki, Nakamura-ku, Nagoya, Aichi 450-0002	TEL : +81(52)581-8521	FAX : +81(52)561-2173
Kyoto	579-32 Higashi Shiokouji-cho, Karasuma Nishi-iru, Shiokoujidori, Shimogyo-ku, Kyoto 600-8216	TEL : +81(75)311-2121	FAX : +81(75)314-6559

(Contact address for overseas customers in Japan)

Yokohama	TEL : +81(45)476-9270	FAX : +81(045)476-9271
----------	-----------------------	------------------------