

NPN Silicon RF Transistor

Preliminary data

- For low current applications
- Smallest Package 1.4 x 0.8 x 0.59mm
- Noise figure $F = 1.25$ dB at 1.8 GHz
outstanding $G_{ms} = 23$ dB at 1.8 GHz
- Transition frequency $f_T = 25$ GHz
- Gold metallization for high reliability
- **SIEGET® 25 GHz f_T - Line**

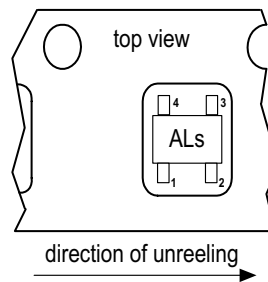
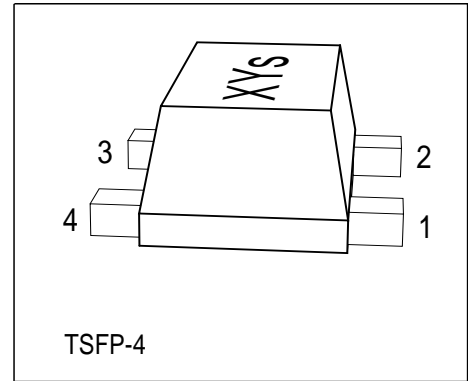

ESD: Electrostatic discharge sensitive device, observe handling precaution!

| Type | Marking | Pin Configuration | | | | Package |
|---------|---------|-------------------|-----|-----|-----|---------|
| BFP405F | ALs | 1=B | 2=E | 3=C | 4=E | TSFP-4 |

Maximum Ratings

| Parameter | Symbol | Value | Unit |
|--|-----------|-------------|------|
| Collector-emitter voltage | V_{CEO} | 4.5 | V |
| Collector-base voltage | V_{CBO} | 15 | |
| Emitter-base voltage | V_{EBO} | 1.5 | |
| Collector current | I_C | 12 | mA |
| Base current | I_B | 1 | |
| Total power dissipation $T_S \leq 122^\circ\text{C}$ 1) | P_{tot} | 55 | mW |
| Junction temperature | T_j | 150 | °C |
| Ambient temperature | T_A | -65 ... 150 | |
| Storage temperature | T_{stg} | -65 ... 150 | |

Thermal Resistance

| | | | |
|--|------------|------------|-----|
| Junction - soldering point ²⁾ | R_{thJS} | ≤ 500 | K/W |
|--|------------|------------|-----|

¹ T_S is measured on the emitter lead at the soldering point to the pcb

² For calculation of R_{thJA} please refer to Application Note Thermal Resistance

Electrical Characteristics at $T_A = 25^\circ\text{C}$, unless otherwise specified.

| Parameter | Symbol | Values | | | Unit |
|--|---------------|--------|------|------|---------------|
| | | min. | typ. | max. | |
| DC characteristics | | | | | |
| Collector-emitter breakdown voltage $I_C = 1 \text{ mA}, I_B = 0$ | $V_{(BR)CEO}$ | 4.5 | 5 | - | V |
| Collector-base cutoff current $V_{CB} = 5 \text{ V}, I_E = 0$ | I_{CBO} | - | - | 150 | nA |
| Emitter-base cutoff current $V_{EB} = 1.5 \text{ V}, I_C = 0$ | I_{EBO} | - | - | 15 | μA |
| DC current gain $I_C = 5 \text{ mA}, V_{CE} = 4 \text{ V}$ | h_{FE} | 50 | 90 | 150 | - |
| AC characteristics (verified by random sampling) | | | | | |
| Transition frequency $I_C = 10 \text{ mA}, V_{CE} = 3 \text{ V}, f = 2 \text{ GHz}$ | f_T | 18 | 25 | - | GHz |
| Collector-base capacitance $V_{CB} = 2 \text{ V}, f = 1 \text{ MHz}$ | C_{cb} | - | 0.05 | 0.1 | pF |
| Collector-emitter capacitance $V_{CE} = 2 \text{ V}, f = 1 \text{ MHz}$ | C_{ce} | - | 0.2 | - | |
| Emitter-base capacitance $V_{EB} = 0.5 \text{ V}, f = 1 \text{ MHz}$ | C_{eb} | - | 0.25 | - | |
| Noise figure $I_C = 2 \text{ mA}, V_{CE} = 2 \text{ V}, Z_S = Z_{Sopt}, f = 1.8 \text{ GHz}$ | F | - | 1.25 | - | dB |
| Power gain, maximum stable ¹⁾ $I_C = 5 \text{ mA}, V_{CE} = 2 \text{ V}, Z_S = Z_{Sopt}, Z_L = Z_{Lopt}, f = 1.8 \text{ GHz}$ | G_{ms} | - | 23 | - | |
| Insertion power gain $I_C = 5 \text{ mA}, V_{CE} = 2 \text{ V}, f = 1.8 \text{ GHz}, Z_S = Z_L = 50\Omega$ | $ S_{21} ^2$ | - | 18 | - | |
| Third order intercept point at output ²⁾ $I_C = 5 \text{ mA}, V_{CE} = 2 \text{ V}, Z_S = Z_L = 50\Omega, f = 1.8 \text{ GHz}$ | IP_3 | - | 14 | - | dBm |
| 1dB Compression point at output ³⁾ $I_C = 5 \text{ mA}, V_{CE} = 2 \text{ V}, f = 1.8 \text{ GHz}, Z_S = Z_L = 50\Omega$ | P_{-1dB} | - | 0 | - | |

$$^1 G_{ms} = |S_{21} / S_{12}|$$

²⁾IP3 value depends on termination of all intermodulation frequency components. Termination used for this measurement is 50 Ω from 0.1MHz to 6GHz.

³⁾DC current no input power

SPICE Parameters (Gummel-Poon Model, Berkley-SPICE 2G.6 Syntax) :

Transistor Chip Data

| | | | | | | | | |
|-------|---------|----|-------|---------|-----|--------|----------|----|
| IS = | 0.21024 | fA | BF = | 83.23 | - | NF = | 1.0405 | - |
| VAF = | 39.251 | V | IKF = | 0.16493 | A | ISE = | 15.761 | fA |
| NE = | 1.7763 | - | BR = | 10.526 | - | NR = | 0.96647 | - |
| VAR = | 34.368 | V | IKR = | 0.25052 | A | ISC = | 0.037223 | fA |
| NC = | 1.3152 | - | RB = | 15 | Ω | IRB = | 0.21215 | A |
| RBM = | 1.3491 | Ω | RE = | 1.9289 | | RC = | 0.12691 | Ω |
| CJE = | 3.7265 | fF | VJE = | 0.70367 | V | MJE = | 0.37747 | - |
| TF = | 4.5899 | ps | XTF = | 0.3641 | - | VTF = | 0.19762 | V |
| ITF = | 1.3364 | mA | PTF = | 0 | deg | CJC = | 96.941 | fF |
| VJC = | 0.99532 | V | MJC = | 0.48652 | - | XCJC = | 0.08161 | - |
| TR = | 1.4935 | ns | CJS = | 0 | fF | VJS = | 0.75 | V |
| MJS = | 0 | - | XTB = | 0 | - | EG = | 1.11 | eV |
| XTI = | 3 | - | FC = | 0.99469 | - | TNOM | 300 | K |

C'-E'-Diode Data (Berkley-SPICE 2G.6 Syntax) :

| | | | | | | | | |
|------|---|----|-----|------|---|------|----|---|
| IS = | 2 | fA | N = | 1.02 | - | RS = | 20 | Ω |
|------|---|----|-----|------|---|------|----|---|

All parameters are ready to use, no scaling is necessary

Package Equivalent Circuit:

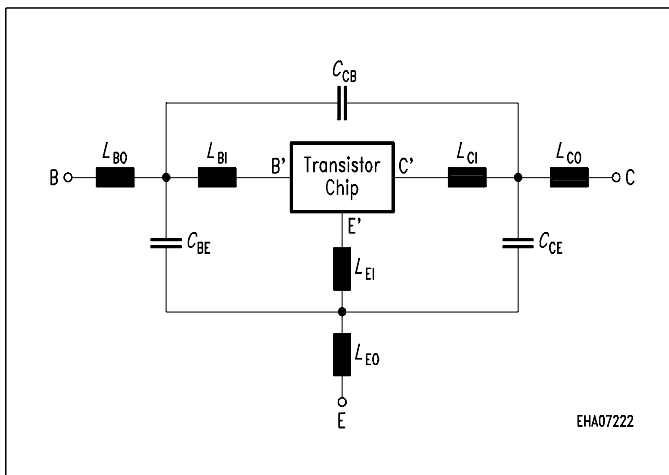

| | | | | | |
|---------------|------|----|---------------|-------|----|
| $L_{BO} =$ | 0.22 | nH | $L_{BI} =$ | 0.42 | nH |
| $L_{EO} =$ | 0.28 | nH | $R_{LBI} =$ | 0.15 | Ω |
| $L_{CO} =$ | 0.22 | nH | $L_{EI} =$ | 0.26 | nH |
| $K_{BO-EO} =$ | 0.10 | - | $R_{LEI} =$ | 0.11 | Ω |
| $K_{BO-CO} =$ | 0.01 | - | $L_{CI} =$ | 0.35 | nH |
| $K_{EO-CO} =$ | 0.11 | - | $R_{LCI} =$ | 0.13 | Ω |
| $C_{BE} =$ | 34 | fF | $K_{CI-EI} =$ | -0.05 | - |
| $C_{BC} =$ | 2 | fF | $K_{BI-CI} =$ | -0.08 | - |
| $C_{CE} =$ | 33 | fF | $K_{BI-EI} =$ | 0.20 | - |

Valid up to 6GHz

The TSFP-4 package has two emitter leads. To avoid high complexity of the package equivalent circuit, both leads are combined in one electrical connection.

R_{Lx} are series resistors for the inductances L_{x} and K_{xa-yb} are the coupling coefficients between the inductances L_{xa} and L_{yb} . The reference pins for the coupled ports are B, E, C, B', E', C'.

For examples and ready to use parameters please contact your local Infineon Technologies distributor or sales office to obtain a Infineon Technologies CD-ROM or see Internet: <http://www.infineon.com/silicondiscretres>

For non-linear simulation:

- Use transistor chip parameters in Berkeley SPICE 2G.6 syntax for all simulators.
- If you need simulation of the reverse characteristics, add the diode with the C'-E'- diode data between collector and emitter.
- Simulation of package is not necessary for frequencies < 100MHz.
For higher frequencies add the wiring of package equivalent circuit around the non-linear transistor and diode model.

Note:

- This transistor is constructed in a common emitter configuration. This feature causes an additional reverse biased diode between emitter and collector, which does not effect normal operation.

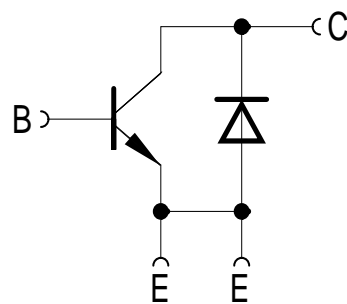

EHA07307

Transistor Schematic Diagram

The common emitter configuration shows the following advantages:

- Higher gain because of lower emitter inductance.
- Power is dissipated via the grounded emitter leads, because the chip is mounted on copper emitter leadframe.

Please note, that the broadest lead is the emitter lead.