

High Frequency NPN Epitaxial Planar Transistor

BTC5177N3

Description

The BTC5177N3 is a NPN Epitaxial Silicon Transistor designed for low noise microwave amplification application.

Symbol

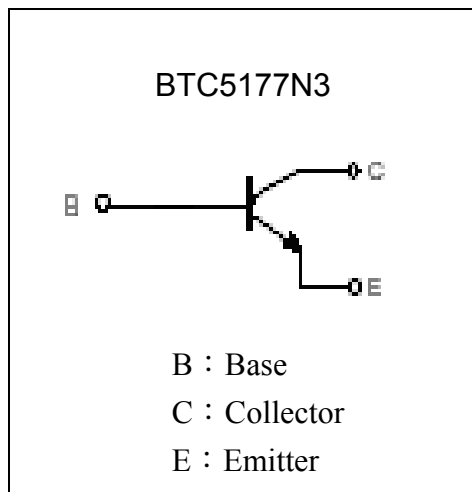

Outline

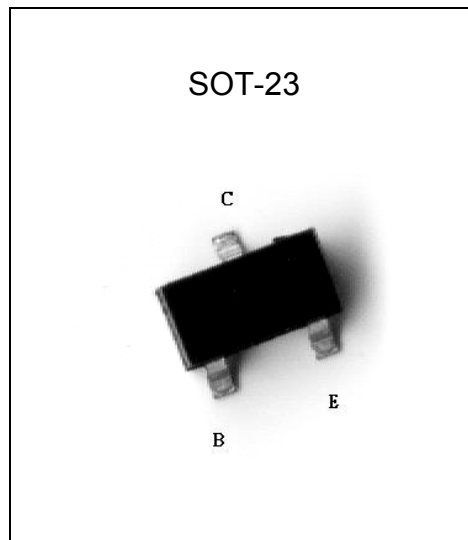

Features

- Low current consumption and high gain:
 $|S_{21e}|^2 = 12\text{dB}$ (typ.) at $V_{CE} = 2\text{V}$, $I_C = 7\text{mA}$, $f = 2\text{GHz}$
 $|S_{21e}|^2 = 11\text{dB}$ (typ.) at $V_{CE} = 1\text{V}$, $I_C = 5\text{mA}$, $f = 2\text{GHz}$
- Mini-mold package

Applications

- Low noise and high gain amplifiers & Oscillator buffer amplifiers

Absolute Maximum Ratings (TA=25°C)

Parameters	Symbol	Limits	Unit
Collector-Emitter Breakdown Voltage	V_{CEO}	3	V
Collector-Base Breakdown Voltage	V_{CBO}	5	V
Emitter-Base Breakdown Voltage	V_{EBO}	2	V
Collector Current	I_C	10	mA
Collector Power Dissipation	P_d	150	mW
Junction Temperature	T_j	150	°C
Storage Temperature	T_{stg}	-65~+150	°C



Electrical Characteristics (TA=25°C)

Parameters	Conditions	Symbol	Min	Typ.	Max	Unit
Collector Cutoff Current	V _{CB} =3V, I _E =0	I _{CBO}	-	-	100	nA
Emitter Cutoff Current	V _{EB} =1V	I _{EBO}	-	-	100	nA
DC Current Gain	V _{CE} =2V, I _C =7mA (Note 1)	h _{FE}	70	-	140	-
Cutoff Frequency	V _{CE} =2V, I _C =7mA, f=2GHz	f _T	-	12	15.5	GHz
	V _{CE} =1V, I _C =5mA, f=2GHz		-	10	13	GHz
Noise Figure	V _{CE} =2V, I _C =3mA, f=2GHz	NF	-	1.5	2.0	dB
	V _{CE} =1V, I _C =3mA, f=2GHz		-	1.5	2.0	dB
Insertion Gain S _{21e} ² in 50Ω system	V _{CE} =2V, I _C =7mA, f=2GHz	S _{21e} ²	10	12	-	dB
	V _{CE} =1V, I _C =5mA, f=2GHz		8.5	11	-	dB
Output Capacitance	V _{CB} =2V, I _E =0, f=1MHz	C _{ob}	-	0.7	1.0	pF

Note 1: Pulse test: Pulse width ≤ 380μs, duty cycle ≤ 2%.

SOT-23 Dimension

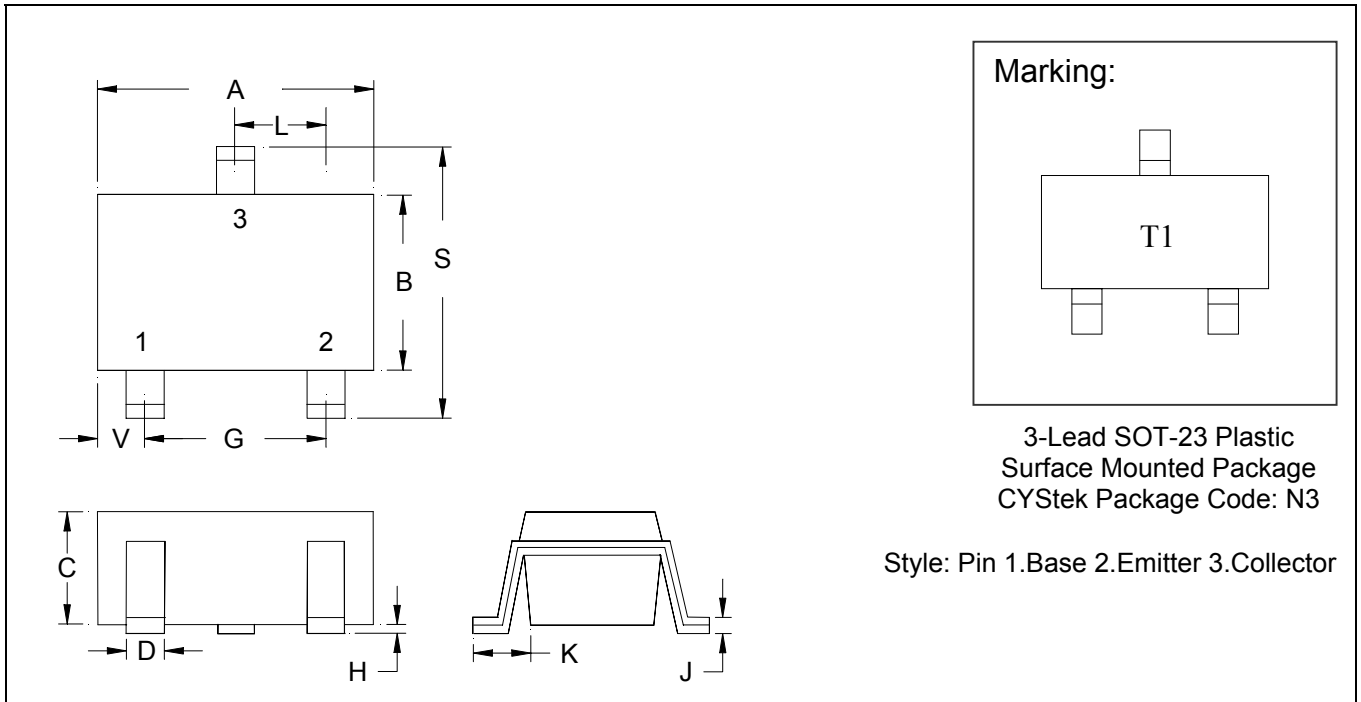

*: Typical

DIM	Inches		Millimeters		DIM	Inches		Millimeters	
	Min.	Max.	Min.	Max.		Min.	Max.	Min.	Max.
A	0.1102	0.1204	2.80	3.04	J	0.0034	0.0070	0.085	0.177
B	0.0472	0.0630	1.20	1.60	K	0.0128	0.0266	0.32	0.67
C	0.0335	0.0512	0.89	1.30	L	0.0335	0.0453	0.85	1.15
D	0.0118	0.0197	0.30	0.50	S	0.0830	0.1083	2.10	2.75
G	0.0669	0.0910	1.70	2.30	V	0.0098	0.0256	0.25	0.65
H	0.0005	0.0040	0.013	0.10					

Notes: 1.Controlling dimension: millimeters.
 2.Maximum lead thickness includes lead finish thickness, and minimum lead thickness is the minimum thickness of base material.
 3.If there is any question with packing specification or packing method, please contact your local CYStek sales office.

Material:

- Lead: 42 Alloy ; solder plating
- Mold Compound: Epoxy resin family, flammability solid burning class: UL94V-0

Important Notice:

- All rights are reserved. Reproduction in whole or in part is prohibited without the prior written approval of CYStek.
- CYStek reserves the right to make changes to its products without notice.
- CYStek **semiconductor products are not warranted to be suitable for use in Life-Support Applications, or systems.**
- CYStek assumes no liability for any consequence of customer product design, infringement of patents, or application assistance.