

HAMAMATSU

DATA SHEET

High Performance Digital CCD Camera C7300-10



▲ Naturally air-cooled (compact) head

This is a high-resolution, high-sensitivity digital CCD camera that achieves a frame rate of 13 Hz (1280 × 1024 pixels) using a 20 MHz / pixel fast-scan clock.

A partial scan function allows the user to select only a specific area for faster scanning, enabling a maximum scan speed of 250 Hz. In addition, a random scan function lets the user select the desired partial scan position for each frame individually.

This instrument is ideal for factory automation applications calling for high-speed processing under a wide range of illumination levels, from faint light to ordinary brightness.

APPLICATIONS

- PIV
- Microscopic image observation in semiconductor and biotechnology fields

SYSTEM CONFIGURATION

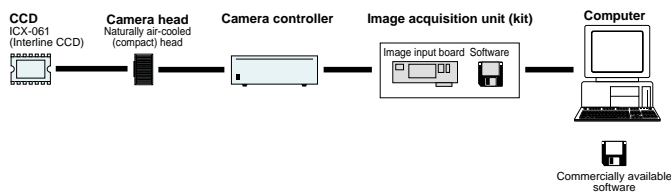

SPECTRAL RESPONSE CHARACTERISTICS

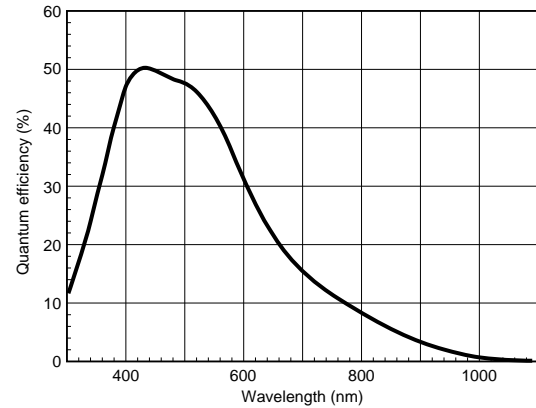

* This is typical, not guaranteed.

FEATURES

- MAX 250 Hz readout (1280 × 16)
- ROI readout function
- Random scan function
- 2 × 2 binning
- 1.3M pixels
- MAX 12-bit output
- UV option (down to 193 nm)
- 60 nsec ultra fast imaging
- 1/10,000 to 1 second integration
- 15 electrons readout noise

TYPE NO.

C7300-10-12

Wavelength

PIV / wavelength specifications

NR: No PIV / Standard wavelength

NRU: No PIV / UV-sensitive type

NRP: With PIV / Standard wavelength

NPD: With PIV / UV-sensitive type

Bit number on A/D converter

12: 12-bit

SPECIFICATIONS

Model name	C7300-10-12-□□	
Camera head type	Naturally air-cooled (compact) head	
Imaging element	ICX-061 Model 2/3 full-pixel scanning interline CCD	
Effective no. of pixels	1280 (H) × 1024 (V)	
Cell size	6.7 (H) × 6.7 (V) μm	
Effective area	8.58 (H) × 6.86 (V) mm	
Readout noise	-	
Full well capacity	13,000 electrons	
Dynamic range	1,000 : 1	
Frame rate	High-precision scan mode	13 Hz (1280 × 1024)
	Fast scan mode	250 Hz (1280 × 16)
Dark current	-	
Exposure time	100 μ sec to 1 sec	
A/D converter	12 bits	
Lens mount	C-mount	
Variable analog gain	1 - 10 times	
Variable offset	Yes	
Binning scan	-	
Sub-array scan	1280 (H) × 16 to 1024 (V) (units of 16 lines)	
Super-pixel scan	2 × 2	
High-speed double exposure function	Two images can be captured at intervals of 200 ns	
External trigger input	Yes	
Output signal (digital output)	Parallel digital output (conforms to RS-422)	
External control	RS-232C	
Ambient storage temperature	-10 to +50 °C	
Ambient operating temperature	0 °C to +40 °C	
Ambient operating/storage humidity	70% max. (with no condensation)	
Line voltage	100 / 117 / 220 / 240 VAC, 50/60 Hz	
Power consumption	Approx. 70 VA	

● Example of sub-array scanning (specified in 16-line steps)

Frame rate (Hz)	250	135	84	47	25	16
No. of pixels (H × V)	1280 × 16	1280 × 64	1280 × 128	1280 × 256	1280 × 512	1280 × 800

FEATURE DESCRIPTIONS

● Selectable sub-array (ROI) function

The C7300 can be set to readout sub-arrays of 1280 pixels by multiples of 16 lines by computer command.

Image area



Up to 8 sub-arrays may be selected from frame to frame at maximum frame rate.

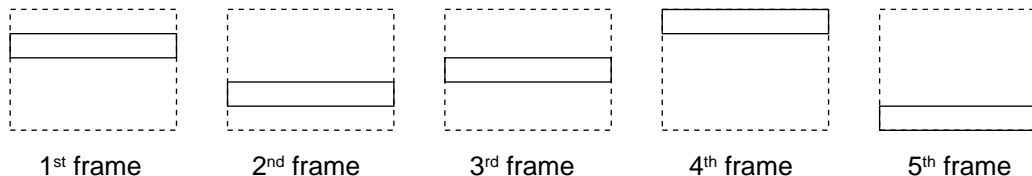

DIMENSIONAL OUTLINES (Unit: mm)

● Camera head (approx. 0.7 kg)

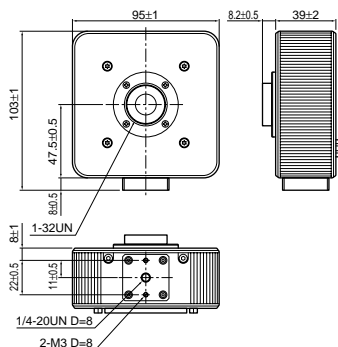

● Camera controller (approx. 6.3 kg)

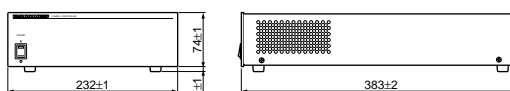

- ★ Product and software package names noted in this documentation are trademarks or registered trademarks of their respective manufacturers.
 - Subject to local technical requirements and regulations, availability of products included in this promotional material may vary. Please consult with our sales office.
 - Information furnished by HAMAMATSU is believed to be reliable. However, no responsibility is assumed for possible inaccuracies or omissions.
- Specifications and external appearance are subject to change without notice.

© 2002 Hamamatsu Photonics K.K.



HAMAMATSU

Homepage Address <http://www.hamamatsu.com>

HAMAMATSU PHOTONICS K.K., Systems Division
812 Joko-cho, Hamamatsu City, 431-3196, Japan, Telephone: (81)53-431-0124, Fax: (81)53-435-1574, E-mail: export@sys.hpk.co.jp

U.S.A. and Canada: Hamamatsu Photonic Systems: 360 Foothill Road, Bridgewater, N.J. 08807-0910, U.S.A., Telephone: (1)908-231-1116, Fax: (1)908-231-0852, E-mail: usa@hamamatsu.com

Germany: Hamamatsu Photonics Deutschland GmbH: Arzbergerstr. 10, D-82211 Herrsching am Ammersee, Germany, Telephone: (49)8152-375-0, Fax: (49)8152-2658, E-mail: info@hamamatsu.de

France: Hamamatsu Photonics France S.A.R.L.: 8, Rue du Saule Trapu, Parc du Moulin de Massy, 91882 Massy Cedex, France, Telephone: (33)1 69 53 71 00, Fax: (33)1 69 53 71 10, E-mail: infos@hamamatsu.fr

United Kingdom: Hamamatsu Photonics UK Limited: 2 Howard Court, 10 Tewin Road Welwyn Garden City Hertfordshire AL7 1BW U.K., Telephone: (44) 1707-294888, Fax: (44) 1701-325777, E-mail: info@hamamatsu.co.uk

North Europe: Hamamatsu Photonics Norden AB: Smidesvägen 12, SE-171-41 Solna, Sweden, Telephone: (46)8-509-031-00, Fax: (46)8-509-031-01, E-mail: info@hamamatsu.se

Italy: Hamamatsu Photonics Italia S.R.L.: Strada della Moia, 1/E 20020 Arese (Milano), Italy, Telephone: (39)02-935 81 733, Fax: (39)02-935 81 741, E-mail: info@hamamatsu.it

Cat. No. SICS1066E06
MAR/2002 HPK
Created in Japan (PDF)