

ELECTRICAL SPECIFICATIONS:

- | | | | |
|---|------------------------------|--|------------|
| 1.0 TURNS RATIO (P6-P5-P4) : | (J6-J3) | : 1CT ± 3% | |
| | (P3-P2-P1) : | (J2-J1) | : 1CT ± 3% |
| 2.0 INDUCTANCE (P6-P4) | | : 350µH MIN. @ 0.1V, 100KHz, 8mA DC Bias | |
| | (P3-P1) | : 350µH MIN. @ 0.1V, 100KHz, 8mA DC Bias | |
| 3.0 LEAKAGE INDUCTANCE P6-P4 (WITH J6 AND J3 SHORT) | | : 0.3 MAX. @ 1MHz | |
| | P3-P1 (WITH J2 AND J1 SHORT) | : 0.3 MAX. @ 1MHz | |
| 4.0 INTERWINDING CAPACITANCE (P6,P5,P4) TO (J6,J3) | | : 30pf MAX @ 1MHz | |
| | (P3,P2,P1) TO (J2,J1) | : 30pf MAX. @ 1MHz | |
| 5.0 DC RESISTANCE (J6-J3)=(J2-J1) | | : 1.2 ohms Max. | |

NOTES

1.0 PINS WITHOUT ELECTRICAL CONNECTION ARE OMITTED.

InNet Technologies inc.
<http://www.innet-tech.com>
 Stewart Connector Systems
<http://www.stewartconnector.com>

SHEET
1 OF 4

DRAWING NO. CH0077-S1 REV 07

6.0 RETURN LOSS: (P6-P4)=100 OHMS AND (P1-P3)=100 OHM REF.
1MHz TO 30MHz : 18dB MIN.
60MHz TO 80MHz : 12dB MIN.

NOTE: 100 OHMS CONNECTED TO (J2-J1) OR (J6-J3).

7.0 VOLTAGE WITHSTAND:
(J1, J2) TO (P1, P3) : 1500 VAC
(J3, J6) TO (P4,P6) : 1500 VAC

8.0 INSERTION LOSS: RS=RL=100 ohms
100KHz TO 100MHz 1.1 dB TYP

9.0 RISE TIME: RS=100 OHMS AND RL = 100 OHMS
OUTPUT VOLTAGE = 1 V peak 3.0 nS MAX
PULSE WIDTH= 112nS 3.0 nS MAX

10.0 CROSS TALK:
1MHz TO 100MHz 40 dB TYP

11.0 COMMON TO COMMON MODE ATTENUATION:
30MHz TO 100MHz 35dB TYP

InNet Technologies inc.
<http://www.innet-tech.com>
Stewart Connector Systems
<http://www.stewartconnector.com>

SHEET
2 OF 4

DRAWING NO. CH0077-S1 REV 07

NOTES:

- TOLERANCES COMPLY WITH F.C.C. DIMENSION REQUIREMENTS
- DIMENSIONS SHOWN WITH "*" TO BE CENTRAL ABOUT CENTER LINE
- DIMENSIONS SHOWN ARE SUBJECT TO CHANGE WITHOUT NOTICE.
- PIN NOT ELECTRICALLY CONNECTED MAYBE OMITTED. SEE ELECTRICAL DRAWING FOR OMITTED PINS.
- HIGH TEMPERATURE VERSION
- 50 MICRO-INCH SELECTIVE GOLD PLATING

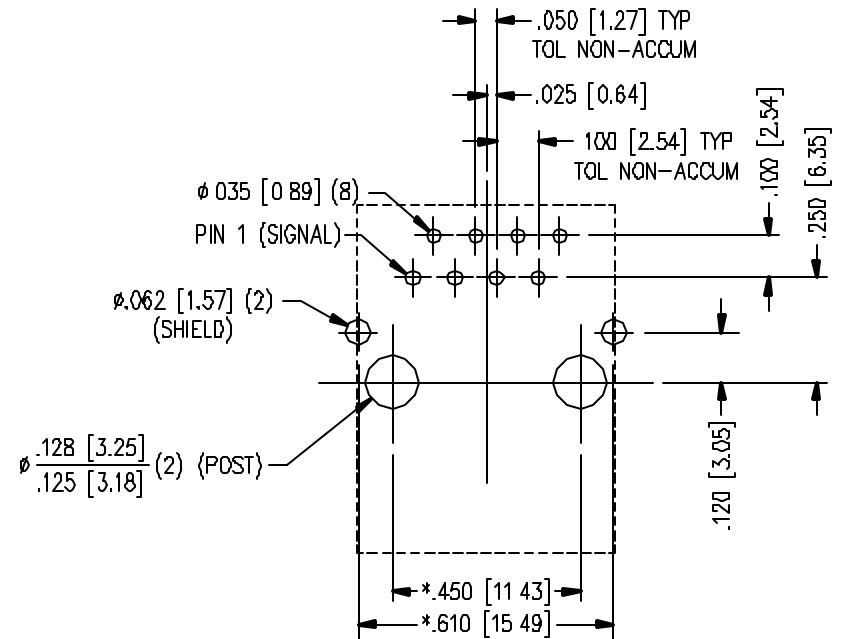
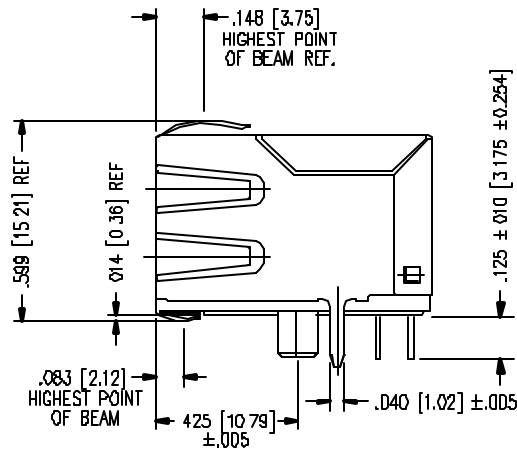
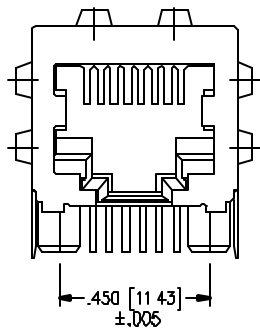
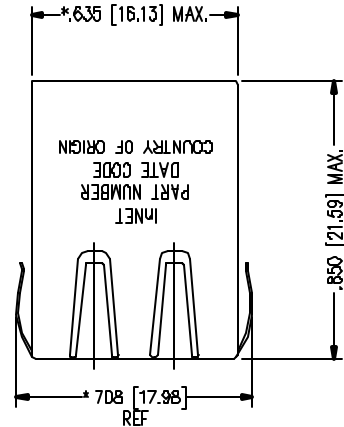

P.C.B. RECOMMENDED HOLE LAYOUT
SEEN FROM COMPONENT SIDE
TOLERANCE $\pm .003 [0.08]$ UNLESS OTHERWISE SPECIFIED

InNet Technologies inc.
<http://www.innet-tech.com>
Stewart Connector Systems
<http://www.stewartconnector.com>

SHEET 3 OF 4	DRAWING NO. CH0077-S1	REV 03
-----------------	--------------------------	-----------

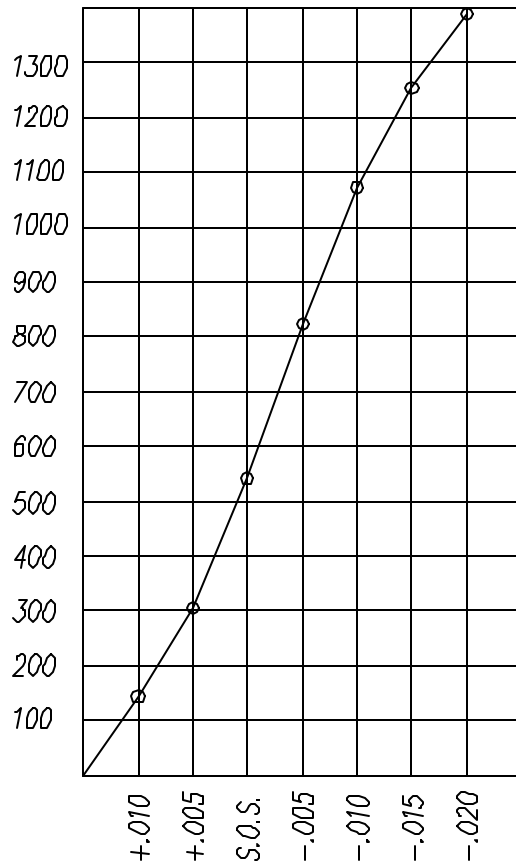

PANEL GROUNDING BEAM DEFLECTION
S.O.S. = SUGGESTED OPENING SIZE

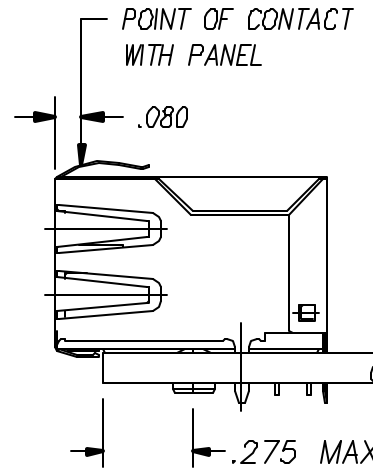

THE SUGGESTED PANEL OPENING IS INTENDED TO GIVE THE USER THE ABILITY TO HAVE REASONABLE JACK / PANEL CLEARANCES YET MAINTAIN RELIABLE GROUNDING CAPABILITY. THESE VARIABLES CAN BE ADJUSTED IN EITHER DIRECTION BUT MAY CARRY SOME CONSEQUENCES IN THE FORM OF LOWER MATING FORCES OR TIGHTER ASSEMBLY TOLERANCES. FORCE VALUES ON THE GRAPH ARE GENERAL AVERAGES TAKEN AT THE POINT OF CONTACT SHOWN ABOVE. THE SUGGESTED PANEL OPENING INCLUDES APPROXIMATELY .020 CLEARANCE ON THE SIDES AND TOP AND .013 ON THE BOTTOM, AT PANEL OPENING.

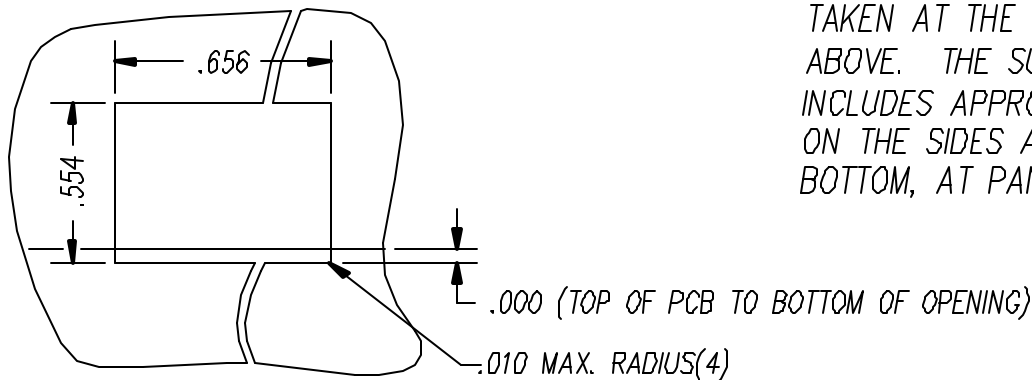

SUGGESTED PANEL OPENING

InNet Technologies inc.
<http://www.innet-tech.com>
 Stewart Connector Systems
<http://www.stewartconnector.com>

SHEET
4 OF 4

DRAWING NO. CH0077-S1 REV 03