

GENERAL DESCRIPTION

The CM1117F series of adjustable and fixed voltage regulators are designed to provide 1A for applications requiring high efficiency. All internal circuitry is designed to operate down to 1V input to output differential and the dropout voltage is fully specified as a function of load current.

The CM1117F offers current limiting and thermal protection. The on chip trimming adjusts the reference voltage accuracy to 2%.

FEATURES

- ◆ Three Terminal Adjustable or Fixed Voltages: 1.8V, 2.5V, 3.3V, and adjustable.
- ◆ Output Current of 1A
- ◆ Low dropout voltage: 1.1V Typ.
- ◆ Line Regulation: 0.3% Max
- ◆ Load Regulation: 2% Max
- ◆ Fast Transient Response
- ◆ Thermal Protection
- ◆ SOT-223 package available
- ◆ Rugged 3KV ESD withstand capability.

APPLICATIONS

- ◆ High Efficiency Linear Regulators
- ◆ Post Regulators for Switching Supplies
- ◆ Battery Chargers
- ◆ Active SCSI Terminators
- ◆ Post Regulator for Switching DC/DC Converter
- ◆ Battery Powered Instrumentation

PIN CONFIGURATION

SOT-223
Top View

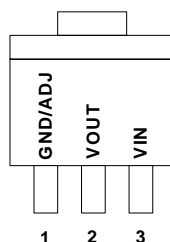

ORDERING INFORMATION

Package Type		Operating Temperature Range (T _A)	Output Voltage
SOT-223			
CM1117FDCM223		0°C ~ +70°C	1.8V
CM1117FKCM223		0°C ~ +70°C	2.5V
CM1117FSCM223		0°C ~ +70°C	3.3V
CM1117FCM223		0°C ~ +70°C	ADJ.
CM1117FGDCM223*		0°C ~ +70°C	1.8V
CM1117FGKCM223*		0°C ~ +70°C	2.5V
CM1117FGSCM223*		0°C ~ +70°C	3.3V
CM1117FGCM223*		0°C ~ +70°C	ADJ.

*Note: G : Suffix for Pb Free Product

ABSOLUTE MAXIMUM RATINGS

Input Voltage +12V
 Operating Junction Temperature Range, T_J 0°C to +125°C
 Storage Temperature -40°C to +150°C
 Lead Temperature (10 sec.) 260°C

THERMAL INFORMATION

Parameter		Maximum	Unit
Thermal Resistance (θ_{ja})	SOT-223	60	°C/W
Internal Power Dissipation (P_D) ($\Delta T = 100^\circ\text{C}$, No Heatsink)	SOT-223	900	mW
Maximum Junction Temperature		125	°C
Maximum Lead Temperature (10 Sec)		260	°C

BLOCK DIAGRAM

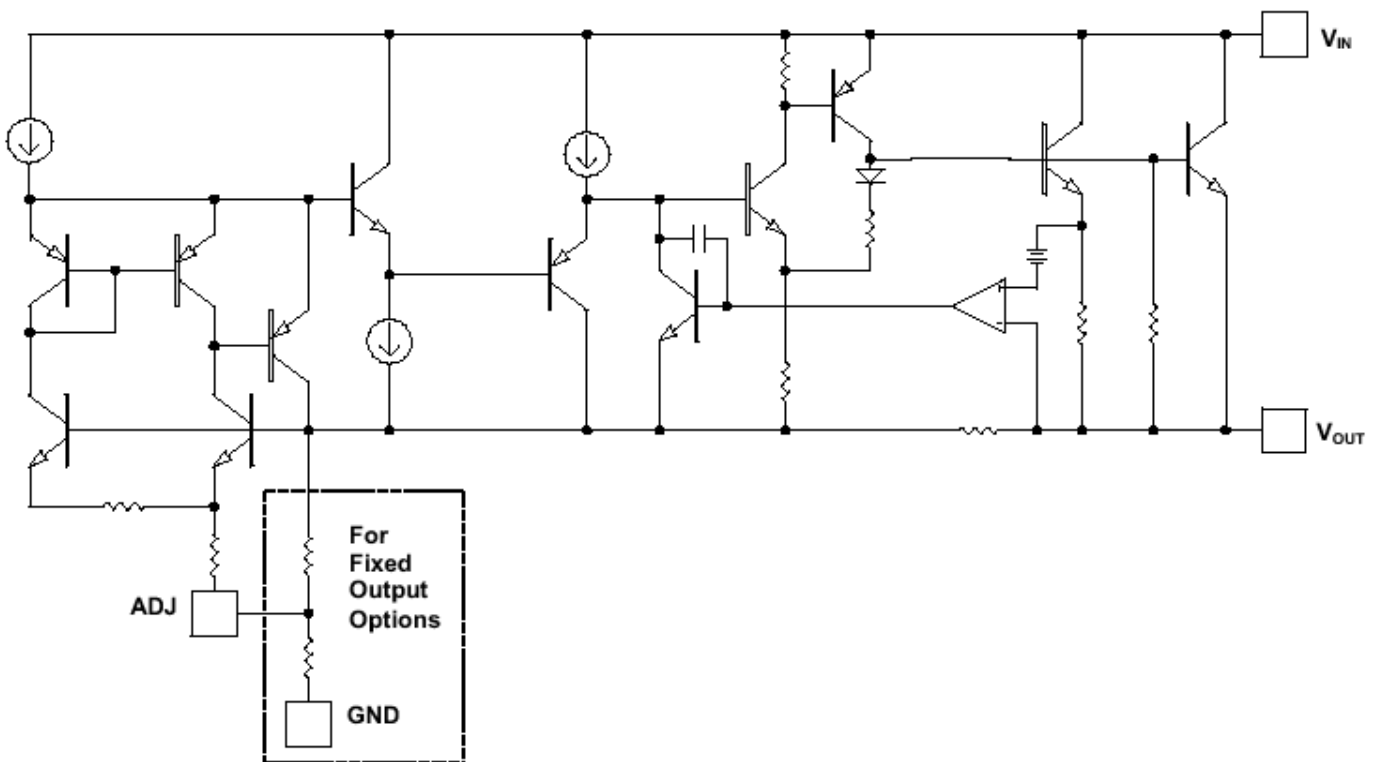

ELECTRICAL CHARACTERISTICS

Electrical Characteristics at $I_{OUT} = 10\text{mA}$, and $T_J = +25^\circ\text{C}$; unless otherwise noted

Parameter	Device	Test Conditions	CM1117F			Unit
			Min.	Typ.	Max.	
Reference Voltage	CM1117F	$I_{OUT} = 10\text{mA}$, $V_{IN} = 5\text{V}$	1.225	1.250	1.275	V
Output Voltage	CM1117FD	$10\text{mA} \leq I_{OUT} \leq 1\text{A}$, $3.2\text{V} \leq V_{IN} \leq 7\text{V}$	1.764	1.800	1.836	V
	CM1117FK	$10\text{mA} \leq I_{OUT} \leq 1\text{A}$, $4.25\text{V} \leq V_{IN} \leq 7\text{V}$	2.450	2.500	2.550	V
	CM1117FS	$10\text{mA} \leq I_{OUT} \leq 1\text{A}$, $4.75\text{V} \leq V_{IN} \leq 7\text{V}$	3.234	3.300	3.366	V
Line Regulator	Adj. Output	$I_{OUT} = 10\text{mA}$, $1.5\text{V} \leq V_{IN} \leq 7\text{V}$		0.05	0.30	%
	Fixed Output	$I_{OUT} = 10\text{mA}$, $V_{OUT} + 1.5\text{V} \leq V_{IN} \leq 7\text{V}$		1	6.0	mV
Load Regulation	Adj. Output	$10\text{mA} \leq I_{OUT} \leq 1\text{A}$, $V_{IN} - V_{OUT} = 3\text{V}$		0.4	2	%
	Fixed Output	$10\text{mA} \leq I_{OUT} \leq 1\text{A}$, $V_{IN} = V_{OUT} + 1.5\text{V}$		8	36	mV
Dropout Voltage ($V_{IN} - V_{OUT}$)	Fixed Output	$I_{OUT} = 10\text{mA}$		1		V
		$I_{OUT} = 1\text{A}$		1.1	1.25	
Current Limit	Fixed Output	$(V_{IN} - V_{OUT}) = 3\text{V}$		1.8		A
Minimum Load Current (Note 1)		$V_{IN} \leq 7\text{V}$	4			mA
Quiescent Current	Fixed Output	$V_{IN} \leq 7\text{V}$		10	13	mA
Ripple Rejection (Note 2)		$f_O = 120\text{Hz}$, $1V_{RMS}$, $I_{OUT} = 1\text{A}$, $(V_{IN} - V_{OUT}) = 3\text{V}$		35		dB
Thermal Regulation (Note 2)		$T_A = 25^\circ\text{C}$, 30ms pulse		0.01	0.1	%W
Adjust Pin Current		$I_{OUT} = 10\text{mA}$, $V_{IN} - V_{OUT} = 2\text{V}$		48	120	μA

Note 1: For the adjustable device, the minimum load current is the minimum current required to maintain regulation. Normally the current in the resistor divider used to set the output voltage is selected to meet the minimum load current requirement.

Note 2: These parameters, although guaranteed, are not tested in production.

APPLICATION CIRCUIT

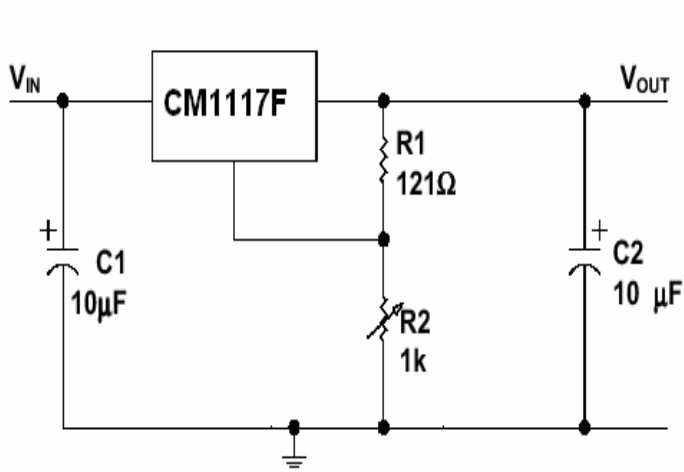

Adjustable Regulator
 $V_{OUT} = 1.25V (1 + R2/R1)$

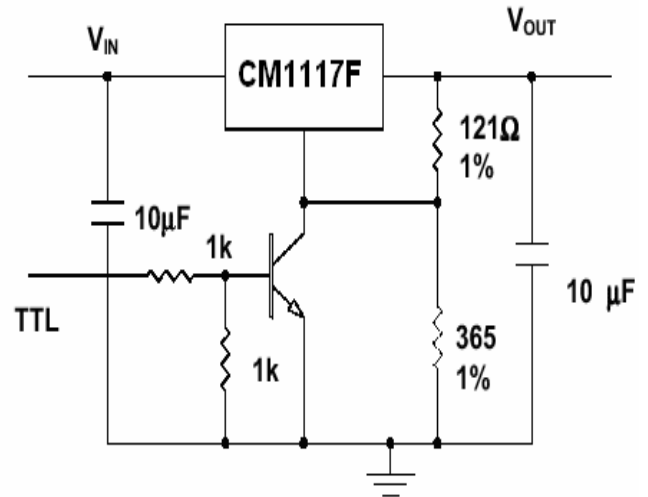

5V Regulator with Shutdown

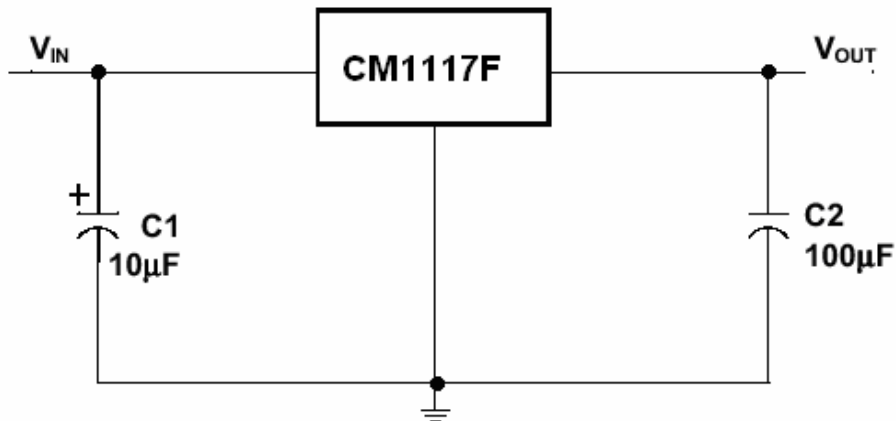

Fixed Voltage Regulator

Application Hints

Like any linear voltage regulator, CM1117F requires external capacitors to ensure stability. The external capacitors must be carefully selected to ensure performance.

Input Capacitor

An input capacitor of at least 10 μ F is required. Ceramic or Tantalum can be used. The value can be increased without upper limit.

Output Capacitor

An output capacitor is required for stability. It must be placed no more than 1 cm away from the V_{OUT} pin, and connected directly between V_{OUT} and GND pins. The minimum value is 22 μ F but may be increased without limit.

Thermal Considerations

It is important that the thermal limit of the package is not exceeded. The CM1117F has built-in thermal protection. When the thermal limit is exceeded, the IC will enter protection, and V_{OUT} will be pulled to ground. The power dissipation for a given application can be calculated as following:

The power dissipation (P_D) is

$$P_D = I_{OUT} * [V_{IN} - V_{OUT}]$$

The thermal limit of the package is then limited to $P_{D(MAX)} = [T_J - T_A]/\Theta_{JA}$ where T_J is the junction temperature, T_A is the ambient temperature, and Θ_{JA} is around 60°C/W for CM1117F. CM1117F is designed to enter thermal protection at 175°C. For example, if T_A is 25°C then the maximum P_D is limited to about 2.5W. In other words, if I_{OUT(MAX)} = 1A, then [V_{IN} - V_{OUT}] cannot exceed 2.5V.

Typical Performance Characteristics

Reference Voltage vs Junction Temperature

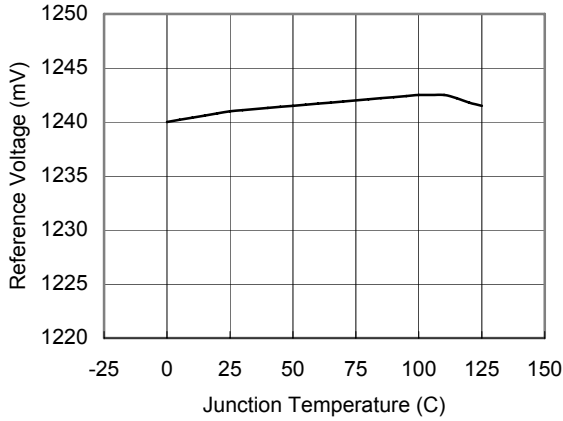

Line Transients

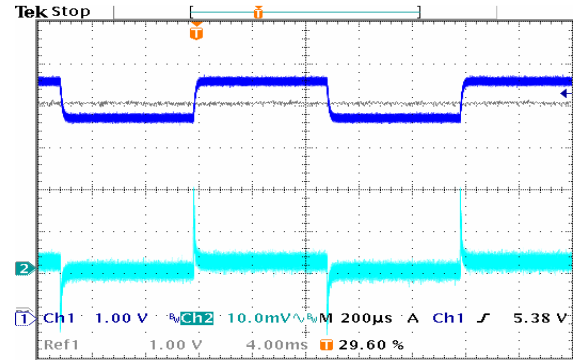

Output Voltage vs Junction Temperature

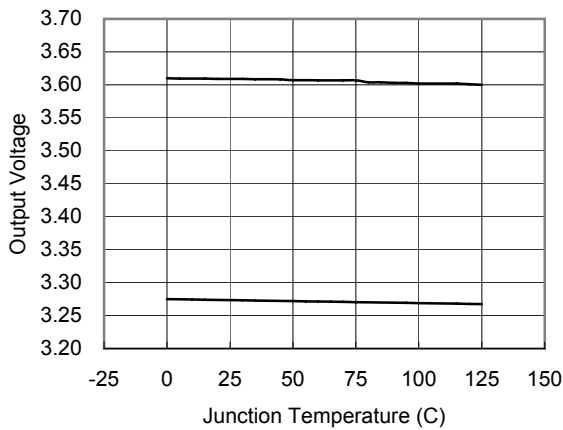

Load Transients

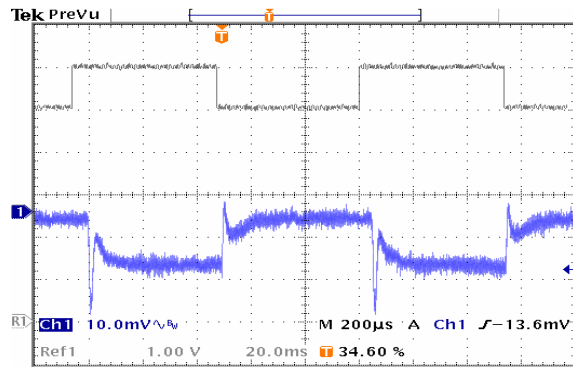

Dropout Voltage vs Output Current

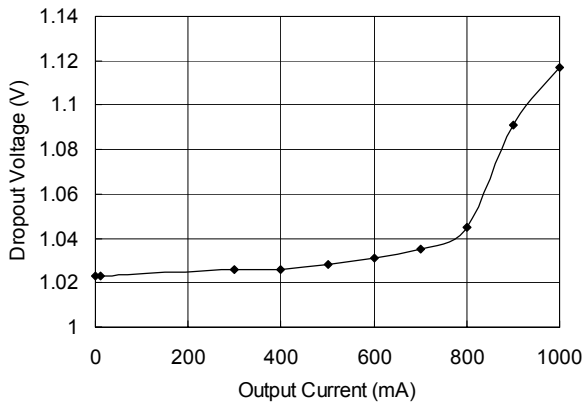

PACKAGE DIMENSION

SOT-223 (M223)

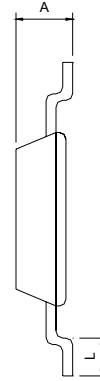
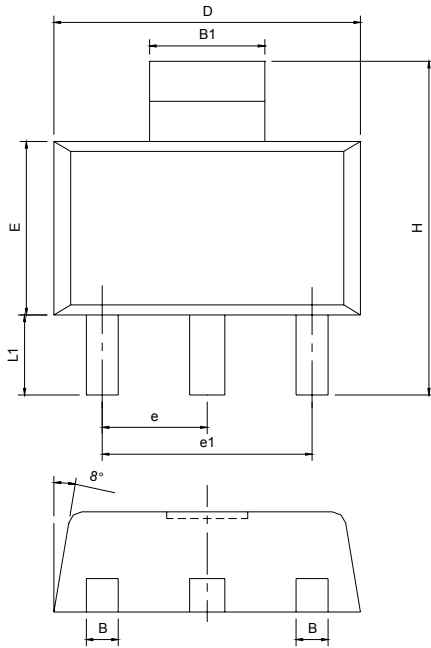

SYMBOLS	DIMENSIONS IN MILLIMETERS			DIMENSIONS IN INCHES		
	MIN	NOM	MAX	MIN	NOM	MAX
A	1.50	---	1.80	0.0591	---	0.0709
B	0.80	---	0.838	0.0314	---	0.0330
B1	2.895	---	3.15	0.114	---	0.124
D	6.299	---	6.708	0.248	---	0.264
E	3.30	---	3.708	0.1299	---	0.146
e	---	2.30±0.1	---	---	0.0909±0.0025	---
e1	---	4.80±0.1	---	---	0.1890±0.0025	---
H	6.70	---	7.30	0.2638	---	0.2874
L	---	0.91MIN	---	---	0.0358MIN	---
L1	---	2.00MAX	---	---	0.0787MAX	---
θ	---	---	13°	---	---	13°

IMPORTANT NOTICE

Champion Microelectronic Corporation (CMC) reserves the right to make changes to its products or to discontinue any integrated circuit product or service without notice, and advises its customers to obtain the latest version of relevant information to verify, before placing orders, that the information being relied on is current.

A few applications using integrated circuit products may involve potential risks of death, personal injury, or severe property or environmental damage. CMC integrated circuit products are not designed, intended, authorized, or warranted to be suitable for use in life-support applications, devices or systems or other critical applications. Use of CMC products in such applications is understood to be fully at the risk of the customer. In order to minimize risks associated with the customer's applications, the customer should provide adequate design and operating safeguards.

HsinChu Headquarter

5F, No. 11, Park Avenue II,
Science-Based Industrial Park,
HsinChu City, Taiwan
TEL: +886-3-567 9979
FAX: +886-3-567 9909

Sales & Marketing

11F, No. 306-3, SEC. 1, Ta Tung Road,
Hsichih, Taipei Hsien 221, Taiwan
TEL: +886-2-8692 1591
FAX: +886-2-8692 1596
