

MODEL NUMBER DHD01988

Coupler/Threshold Detector

FEATURES

- Integrated Coupler and Threshold Detector
- -20 to 0 dBm Dynamic Range
- Adjustable Threshold Level
- 0.2 dB Hysteresis
- 1 mA Sink/Source Current
- 14 Pin DIP

TD

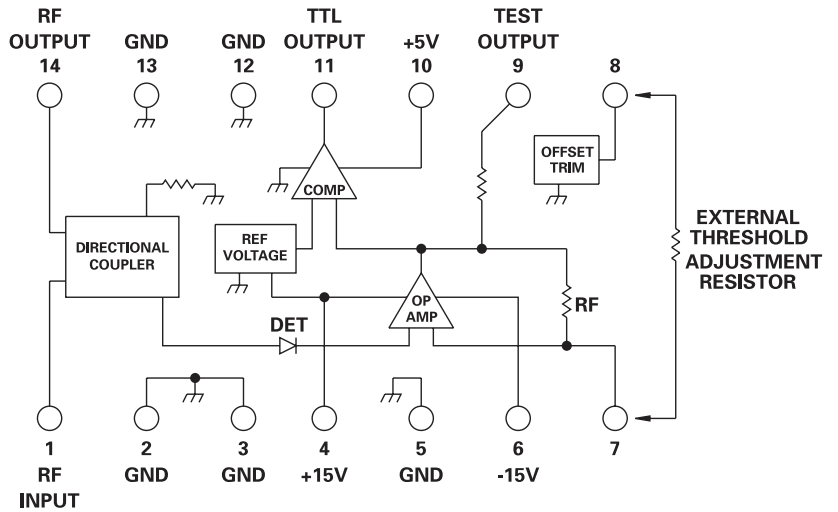
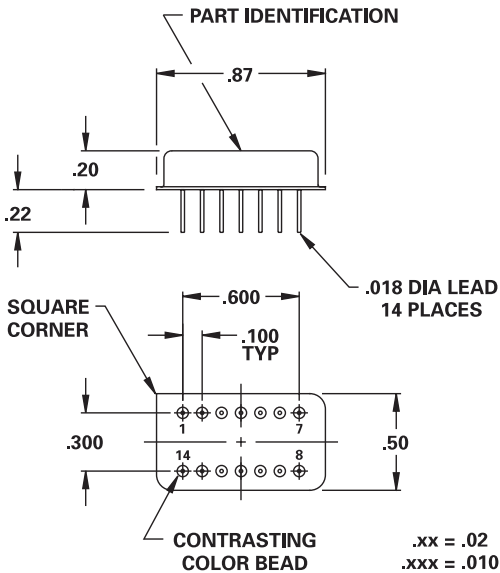

GUARANTEED PERFORMANCE

Parameter	Min	Typ	Max	Units	Conditions
Operating Frequency	20	160	500	MHz	
Dynamic Range	-20		0	dBm	Via an External Resistor Control
Hysteresis		0.2	1.2	dB	
Temperature Stability		±0.6	±1.5	dB	
Insertion Loss		1.2	1.5	dB	20 - 180 MHz
		1.4	1.8	dB	180 - 500 MHz
Input Flatness		±0.4	±1	dB	
Response Time		3		µSec	3 dB Above CW Threshold At RF In to 90% / 10% or 10% / 90% At TTL Out
Input VSWR		1.1/1	1.3/1		
Output Current	Source	1	29	mA	VOH = +2.7 V
	Sink	1	9	mA	VOL = +0.5 V
DC Current		2	20	mA	At +5 VDC
		6	15	mA	At +15 VDC
		6	15	mA	At -15 VDC
Operating Temperature	0	+25	+50	°C	TA