

Design Idea DI-93

PeakSwitch™ General Purpose

32 W Continuous (81 W Peak) Supply



Application	Device	Power Output	Input Voltage	Output Voltage	Topology
Inkjet Printer	PKS606Y	32 W / 81 W pk	90-265 VAC	30 V	Flyback

Design Highlights

- Delivers up to 2.5 times the full load power for 50 ms
- Uses a small EE25 core transformer
- Meets EPS active-mode efficiency specifications
- No-load input power <200 mW at 265 VAC
- High standby and sleep mode efficiency: >66% and 75%

Operation

This supply is configured as a flyback converter. The ON/OFF controller integrated within the PeakSwitch IC (U1) has an internal oscillator frequency of 277 kHz. Feedback from the output causes the controller to skip MOSFET switching cycles to regulate the output voltage. The skipping of switching cycles adjusts the converter's effective switching frequency (F_{SW_EFF}) to meet the demands of the load. When delivering 32 W continuously, the F_{SW_EFF} is near 90 kHz. When the load demands peak power from the supply, the controller skips fewer switching cycles, raising the F_{SW_EFF} . This enables the supply to deliver peak power pulses of up to 81 W (for up to 50 ms), while keeping the output voltage in regulation.

PeakSwitch has three functions that interact with each other: auto-restart, conditional latching shutdown and smart AC line sense. Components D5, C7, R5 and R6 enable the smart AC line sense and the under-voltage lockout (UVLO) functions. When U1 does not skip any switching cycles for >30 ms, the auto-restart function activates. If AC line voltage is absent or insufficient for normal operation when auto-restart activates, latching shutdown is disabled, and normal operation will resume after the AC line voltage is restored. If AC line voltage is sufficient for normal operation when auto-restart activates, latching shutdown is enabled, and AC power must be removed and reapplied to reset the latch. The low value of C7 enables the latch reset to occur quickly, once AC is removed.

The smart AC line sense components also enable the UVLO function. UVLO inhibits MOSFET switching until current into the EN/UV pin is >25 μ A. Resistor R16 supplies the 1 μ A threshold current that activates the UVLO and AC sense features, keeping those functions activated during brownouts and line sags.

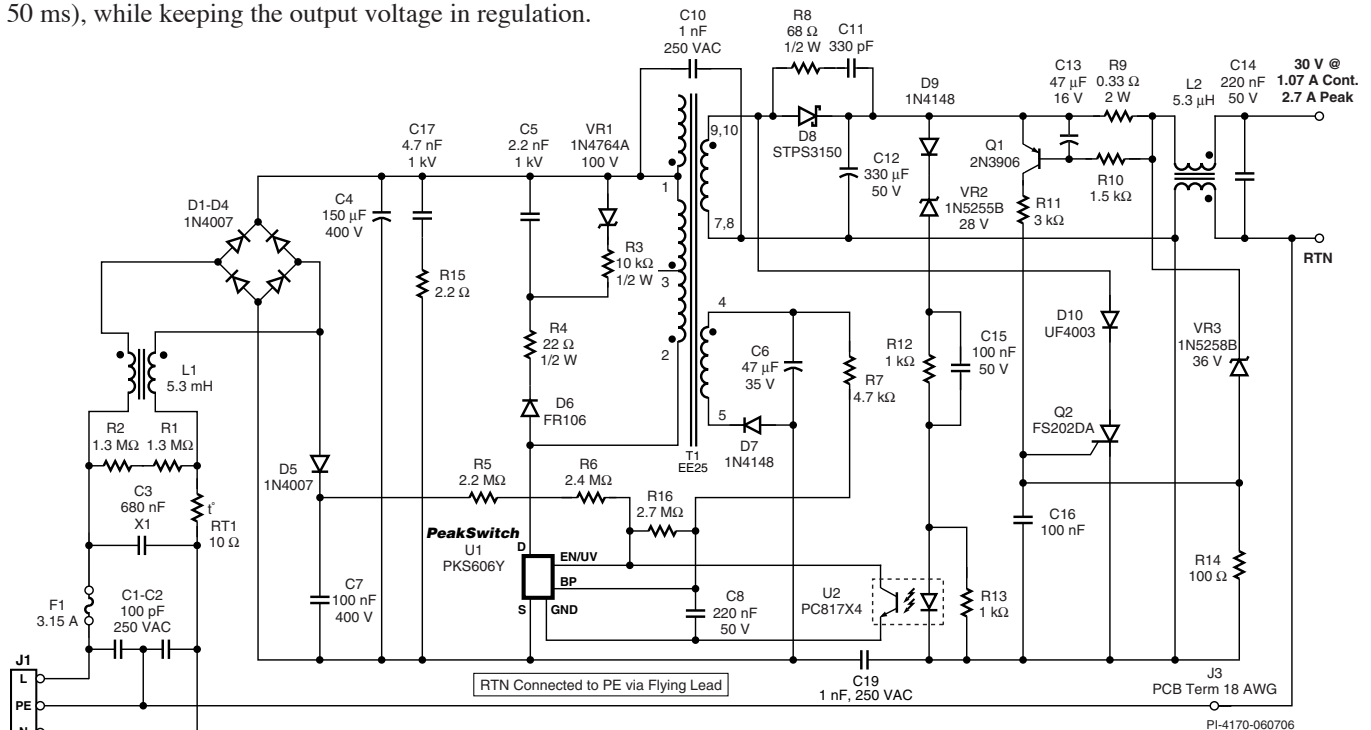

Figure 1. 32 W (Continuous), 81 W (Peak) Power Supply Using PKS606Y.

Ten components enable load overvoltage and over-current protection: C13, C16, D10, Q1, Q2, R9, R10, R11, R14 and VR3. They work with the latching shutdown function as follows:

- If the supply output voltage goes above 36 V, VR3 conducts and turns on Q2, which shorts the secondary winding of T1. After 30 ms of U1 receiving no feedback, the supply latches off.

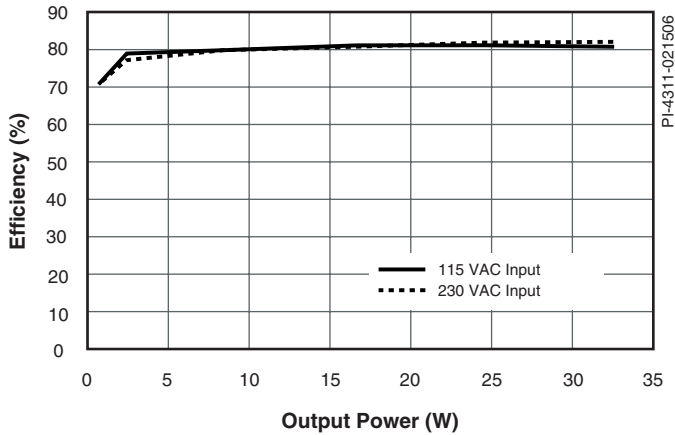

Figure 2. Active-Mode Efficiency Performance.

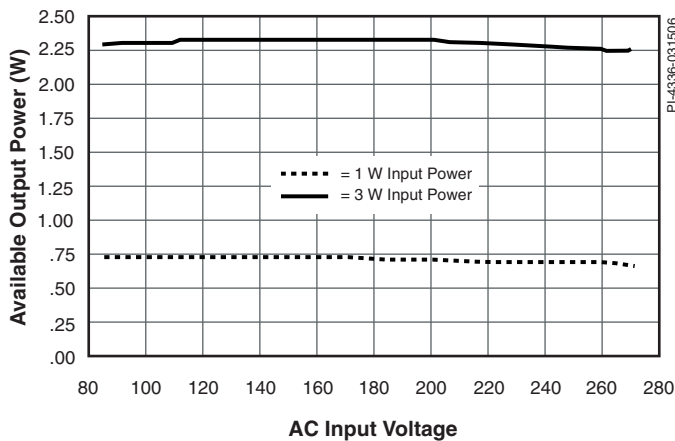

Figure 3. Available Output Power at 1 W and 3 W Input Power.

For the latest updates, visit www.powerint.com

Power Integrations reserves the right to make changes to its products at any time to improve reliability or manufacturability. Power Integrations does not assume any liability arising from the use of any device or circuit described herein. POWER INTEGRATIONS MAKES NO WARRANTY HEREIN AND SPECIFICALLY DISCLAIMS ALL WARRANTIES INCLUDING, WITHOUT LIMITATION, THE IMPLIED WARRANTIES OF MERCHANTABILITY, FITNESS FOR A PARTICULAR PURPOSE, AND NON-INFRINGEMENT OF THIRD PARTY RIGHTS. The products and applications illustrated herein (transformer construction and circuits external to the products) may be covered by one or more U.S. and foreign patents or potentially by pending U.S. and foreign patent applications assigned to Power Integrations. A complete list of Power Integrations' patents may be found at www.powerint.com. Power Integrations grants its customers a license under certain patent rights as set forth at <http://www.powerint.com/ip.htm>.

The PI logo, **TOPSwitch**, **TinySwitch**, **LinkSwitch**, **DPA-Switch**, **PeakSwitch**, **EcoSmart**, **Clampless**, **E-Shield**, **Filterfuse**, **PI Expert** and **PI FACTS** are trademarks of Power Integrations, Inc. Other trademarks are property of their respective companies. ©Copyright 2006, Power Integrations, Inc.

- If the load pulls peak current for longer than the RC time constant (≈ 60 ms) of C13 and R10, Q1 turns on, which turns Q2 on and shorts the secondary winding of T1. Again, after 30 ms of U1 receiving no feedback, the supply latches off.

Capacitor C17 attenuates differential-mode conducted EMI. Resistor R15 dampens high frequency ringing.

Key Design Points

- The value of C7 sets the reset time of the latched shutdown function, once the AC input is removed. Verify that the latch resets, within the time allowed, at the highest input voltage.
- For thermal considerations, the *PeakSwitch* IC, the output diode and their heatsinks, and the transformer core size depend on the continuous-to-peak power ratio, and the duration and frequency of the peak power pulses.
- Choose the values for R10 and C13 so that normal peak loads will not turn Q1 on. However, do not set the RC time constant so long that the supply does not latch off within the 60 seconds specified by IEC 60950-1, section 2.5, Table 2B (Limited Power Sources requirements).

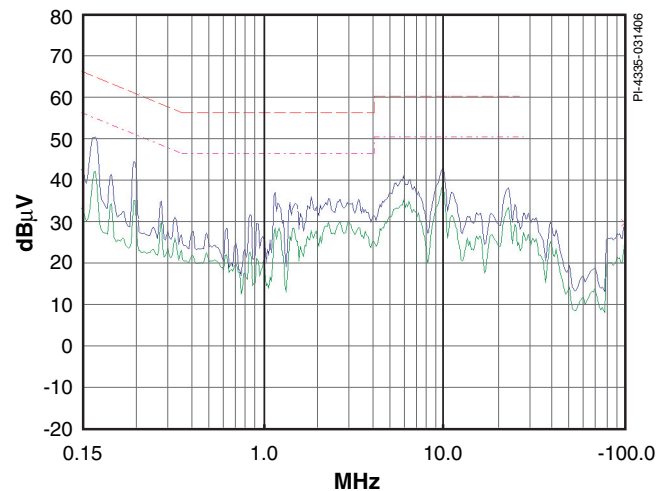

Figure 4. Conducted EMI to EN55022 B Limit, at Full Load, with 115 VAC, 60 Hz Input Voltage.

Power Integrations

5245 Hellyer Avenue

San Jose, California 95138

MAIN PHONE NUMBER
+1 408-414-9200

APPLICATIONS HOTLINE
+1 408-414-9660

APPLICATIONS FAX
+1 408-414-9760

For a complete listing of worldwide sales offices,
please visit www.powerint.com