

Preliminary



- Network Router
- Compatible with RFM miniMESH™ Network Protocol
- 3 V, Very Low Current Operation
- Ready-to-Use OEM Module

The DM1800-434MR is the 433.92 MHz router module in the DM1800 family of RF transceivers. The DM1800 family is designed for adding embedded wireless connectivity to a wide range of monitoring and control systems. This module is compatible with RFM's miniMESH™ network protocol, which provides add-on "plug- and-play" multicast mesh network routing. Radio communications range in an "open field" environment is typically 200 meters/hop. The DM1800-434MR combines RFM's very low current ASH radio technology with low power microcontroller technology to achieve long battery life. The DM1800-434MR is designed for operation under ETSI I-ETS 300 220 regulations.

DM1800-434MR

433.92 MHz Transceiver Module

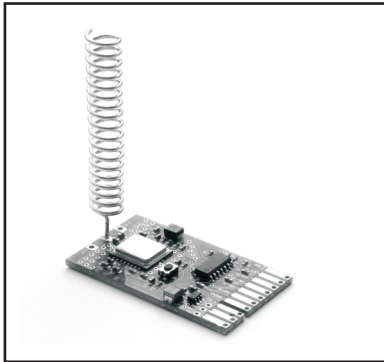

Absolute Maximum Ratings

Rating	Value	Units
All Input/Output Pins Except VIN	-0.3 to +3.3	V
Non-Operating Ambient Temperature Range	-50 to +100	°C

Electrical Characteristics

Characteristic	Sym	Notes	Minimum	Typical	Maximum	Units
Operating Frequency	f _o		433.72		434.12	MHz
Modulation Type				OOK		
RF Encoded Data Transmission Rate				4.8		kb/s
Average Receiver Input Current, No External Power Supply Load	I _R			4		mA
Receiver Input Signal for 10 ⁻³ BER, 25 °C				-103		dBm
Peak Transmitter Input Current, No External Power Supply Load	I _{TP}				13.5	mA
Peak Transmitter Output Power	P _O			1		mW
Digital In Logic High			2.4			V
Digital In Logic Low					.45	V
Power Supply Input Voltage Range, -40 to +85 °C	VIN		3.1		14	V
Power Supply Input Voltage Range, 0 to +85 °C	VIN		2.6		14	V
Regulated Power Supply Output Voltage, VIN 3.1 to 14 V	VOU			3.0		Vdc
Regulated Power Supply Voltage Ripple					10	mV _{P-P}

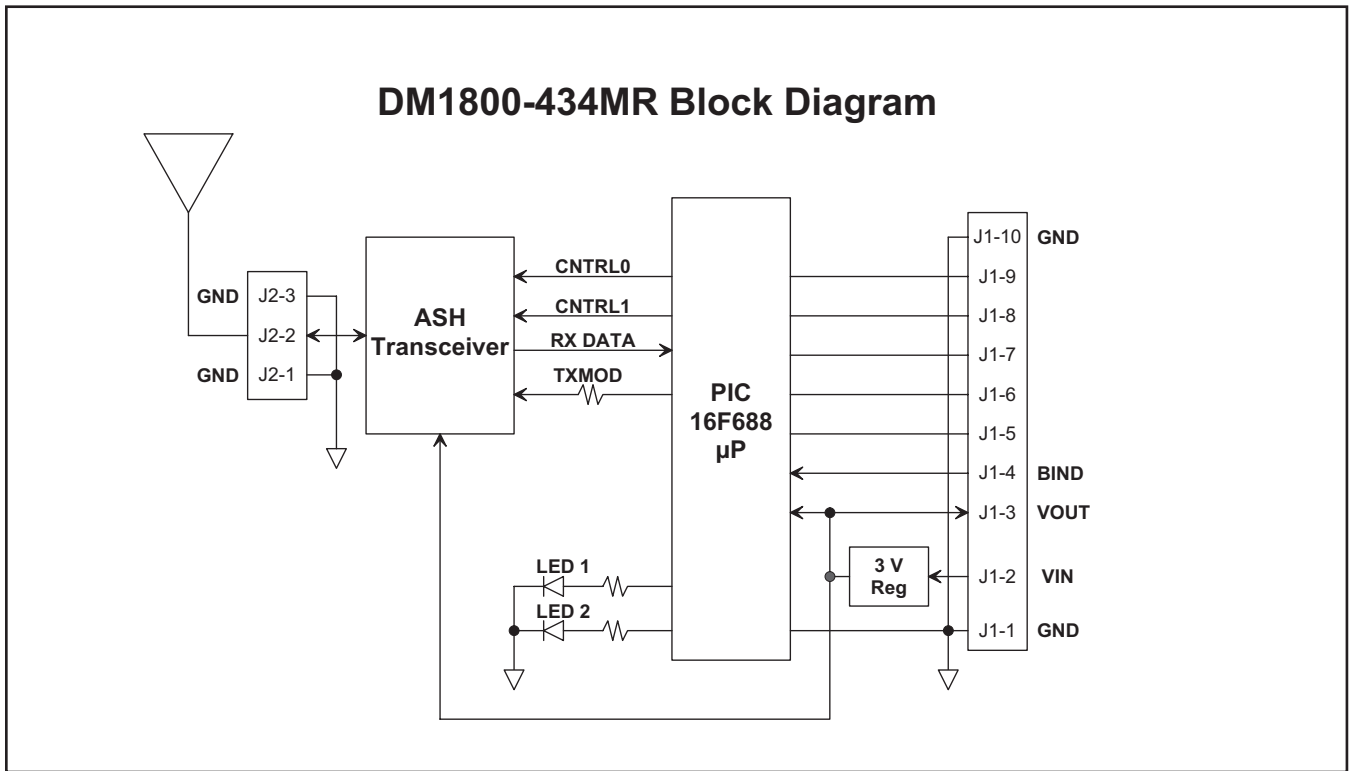

Figure 1

Theory of Operation

The major components of the DM1800-433.92MR include an RFM TR3000 ASH transceiver and a Microchip PIC16F688 microcontroller. The TR3000 operates on a frequency of 433.92 MHz, at a nominal output power of 1 mW. The DM1800 includes two LEDs that indicate the module's operat-

ing mode. The LEDs can be disabled for low current operation.

The DM1800-434MR is compatible with RFM's miniMESH™ network protocol, which provides add-on “plug-and-play” multicast mesh network routing to improve communication range and robustness.

DM1800-434MR I/O Pad Descriptions

Pin	Name	Description
J1-1	GND	This pad is a signal and power supply ground.
J1-2	VIN	This is the power supply input pad. The allowed input voltage range is 2.6 to 14 V.
J1-3	VOUT	VOUT tracks 50 to 100 mV below VIN when VIN is in the range of 2.6 to 3.1 V. When VIN is in the range of 3.1 to 14 V, VOUT is regulated at 3.0 Vdc. Up to 10 mA can be supplied from this pad for powering external circuits such as thermistor-resistor networks. External circuitry must not impress more than 10 mV _{p-p} ripple on the regulated output voltage.
J1-4	BIND	This pad is connected to a logic input on the microcontroller, and is configured with a weak pull-up. When this pin is momentarily grounded (to J1-1 or J1-10, the module is placed into the bind mode, allowing this module to be associated with other modules to form a network.
J1-10	GND	This pad is a signal and power supply ground.
J2-1	GND	This pad is a ground for the antenna port.
J2-2	ANT	This pad is the antenna port.
J2-3	GND	This pad is a ground for the antenna port.

DM1800-434MR I/O Pad Labels

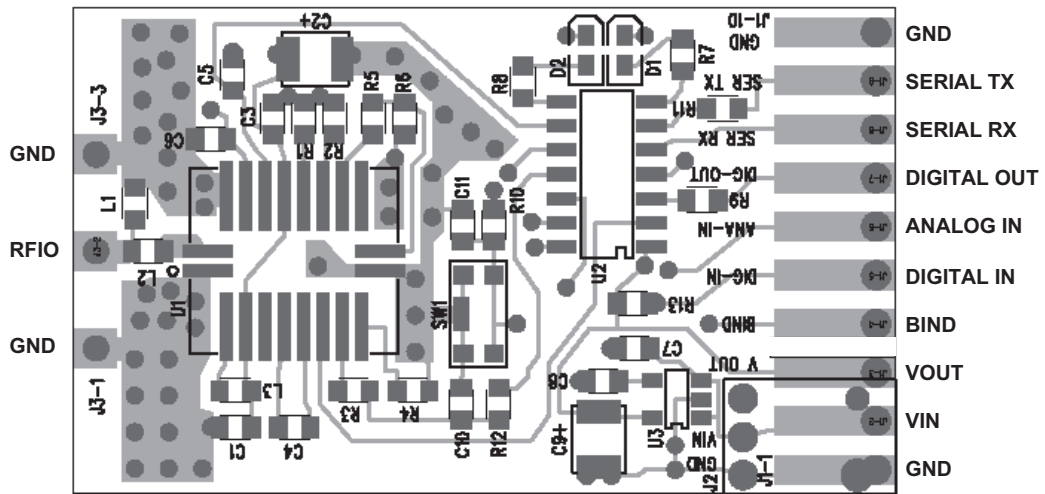
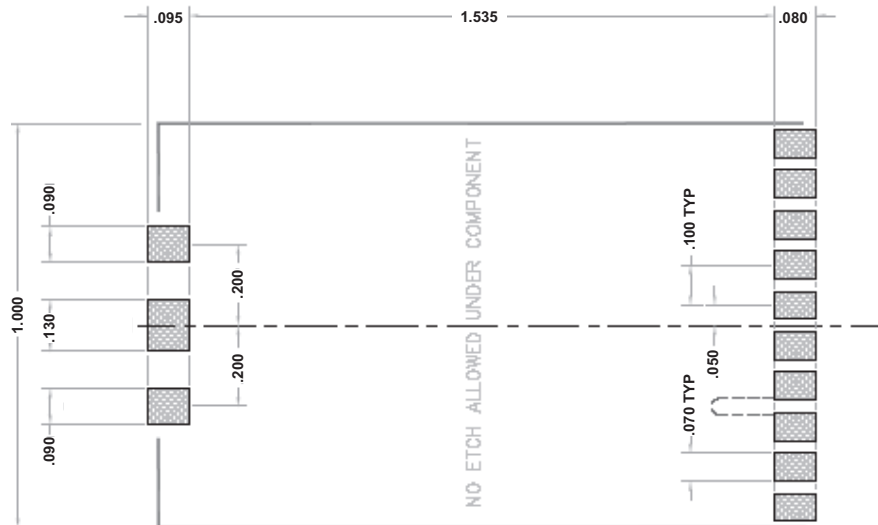

Figure 2

DM1800-434MR SMT Mounting Pattern



Dimensions in inches. PCB plus component height is .170 max;
PCB plus antenna height is 2.15 max

Figure 3

Note: Specifications subject to change without notice.