

## INTRODUCTION

This easy-to-use kit provides a platform for the evaluation of linear power amplifiers circuits using the PA92/PA93 pin-out. With ample breadboarding areas it is flexible enough to analyze a multitude of standard or proprietary circuit configurations. Critical connections for power supply bypassing, compensation and current limiting are pre-wired. Components not usually readily available in engineering labs are provided. External connection to the evaluation kit can be made via the terminals at the edge of the circuit board. These terminal pads are suitable for standard banana jacks or direct soldering of wires. The schematic is shown in Figure 2.

## PARTS LIST

| Part #     | Description, Vendor                            | Quantity      |
|------------|--|---------------|
| HS23       | Heatsink, Wakefield 232-200AB                  | 1             |
| HS20       | Heatsink, Apex                                 | 1             |
| MS06       | Mating Socket Strip, Apex                      | 1 bag, 2 ea.  |
| EVAL20     | PC Board, Apex                                 | 1             |
| TW07       | Thermal Washer, Apex                           | 1 box, 10 ea. |
| ZX7R105KTL | Capacitor, NOVACAP ST2225K501LLXW              | 2             |
| EC02       | Capacitor, United Chemicon KME400VB33RM16X31LL | 2             |
| CSR05      | Resistor, Caddock MP930-0.30 1%                | 1             |
| CSR06      | Resistor, Caddock MP930-0.20 1%                | 1             |
| CSR07      | Resistor, Caddock MP930-0.10 1%                | 1             |

## ASSEMBLY

- See Figure 1. Solder the surface mount ceramic capacitors to the DUT side of the circuit board at C1 and C2.
- Solder the electrolytic capacitors to the circuit board at C3 and C4. Match the polarity markings on the circuit board with those on the capacitor body.
- Select a current limiting resistor from the three values provided. See the product data sheet for information on how to select a value. Apply a thin coating of thermal grease to the back of the resistor. Using a 4-40 X 1/4" screw and 4-40 nut, mount the resistor to the lower of the two holes in the small heat sink provided. Solder this assembly to the circuit board at R<sub>LIM</sub>. After soldering the resistor leads the tabs on the heat sink may be bent with pliers to secure it to the circuit board.
- Examine the large heat sink. Notice that there are several holes in the face of the heat sink. These are for mounting various Apex amplifier models. The circuit board aligns the amplifier with the correct mounting hole once the heat sink is attached to the circuit board. The heat sink can be mounted in either of two positions. One position is used for mounting the amplifier to the heat sink **without** the mating socket strip (the mounting hole of the amplifier is closer to the circuit board). Rotating the heat sink 180 degrees allows mounting the amplifier **with** the mating socket strip (the mounting hole of the amplifier is further from the circuit board).
- While developing your application circuit you will probably want to use the mating socket strip. Clip off the strip after the 12th position. Insert the strip into the circuit board from the DUT side and solder one pin on the reverse side. Check that the mating socket strip is fully seated against the circuit board then solder the remaining pins. Insert the amplifier fully into the mating socket strip, noting the pin 1 locations on the amplifier and the circuit board.
- The four holes at the corners of the circuit board are for mounting #6 standoff spacers if desired. The remaining two slotted holes are for mounting the large heat sink to the DUT side of the circuit board. Temporarily mount the heat sink with 2 #6 X 1/2" self tapping screws from the opposite side of the circuit board. Do not fully tighten the screws at this time. Check for alignment of the slot in the mounting tab of the amplifier with a hole in the heat sink. Dismount and rotate the heat sink if necessary to achieve an alignment with a hole in the heat sink. Position the heat sink so that the back of the amplifier mounting tab is flush with the heat sink then tighten the heat sink mounting screws.
- Hang the thermal washer near the end of a 6-32 X 1/2" screw. Slightly pull the amplifier away from the heat sink face. Use the screw to position the thermal washer behind the amplifier and insert the screw into the mounting hole of the heat sink. Secure the screw from the opposite side of the heat sink using a nut holder.
- Add other components as necessary to complete your application circuit.

# EK16

EVALUATION KIT  
FOR PA92/PA93 PIN-OUT

FIGURE 1.

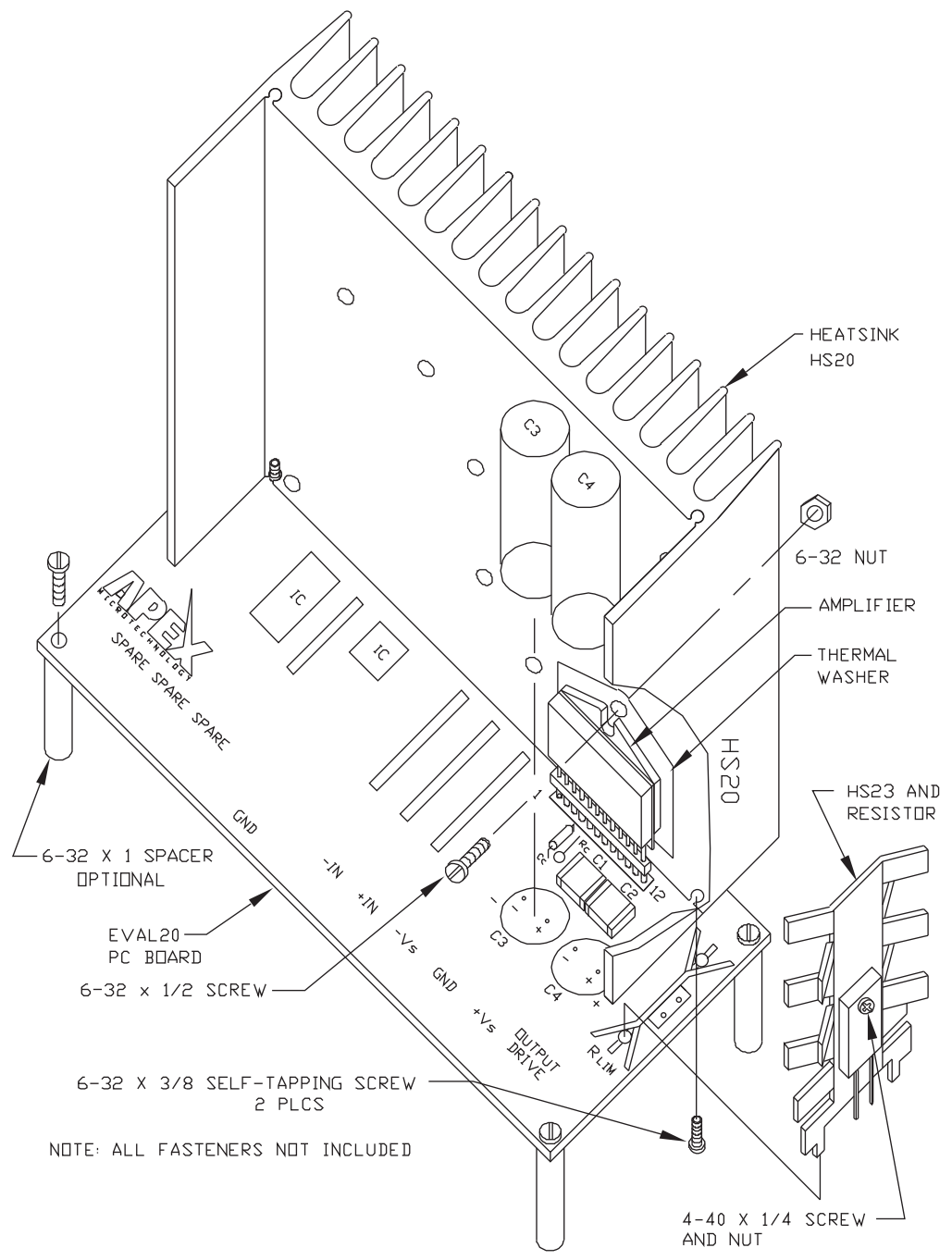

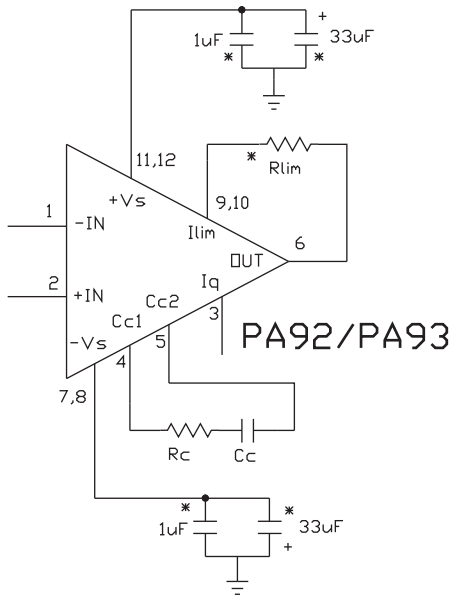

\* COMPONENTS SUPPLIED WITH EVALUATION KIT.

FIGURE 2.

Figure 2 shows the schematic of the evaluation kit's pre-wired connections. Components supplied with the kit are marked with an asterisk (\*). All other connections are made via the breadboarding areas of the circuit board.

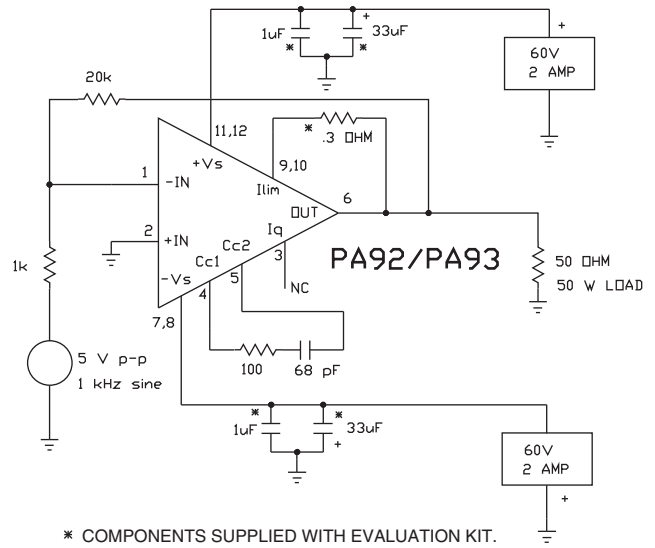

\* COMPONENTS SUPPLIED WITH EVALUATION KIT.

FIGURE 3.

Figure 3 shows a suggested simple test circuit that you can build to gain a familiarity with the evaluation kit as well as the amplifier. At the output (pin 6) you should observe a 100 V p-p sine wave.

FIGURE 4. PCB

