eKK6111

**RF Keyboard
Decoder**

**Product
Specification**

DOC. VERSION 1.0

ELAN MICROELECTRONICS CORP.

November 2002



Trademark Acknowledgments:

IBM is a registered trademark and PS/2 is a trademark of IBM.

Windows is a trademark of Microsoft Corporation.

ELAN and ELAN logo  are trademarks of ELAN Microelectronics Corporation.

Copyright © 2005 by ELAN Microelectronics Corporation

All Rights Reserved

Printed in Taiwan

The contents of this specification are subject to change without further notice. ELAN Microelectronics assumes no responsibility concerning the accuracy, adequacy, or completeness of this specification. ELAN Microelectronics makes no commitment to update, or to keep current the information and material contained in this specification. Such information and material may change to conform to each confirmed order.

In no event shall ELAN Microelectronics be made responsible for any claims attributed to errors, omissions, or other inaccuracies in the information or material contained in this specification. ELAN Microelectronics shall not be liable for direct, indirect, special incidental, or consequential damages arising from the use of such information or material.

The software (if any) described in this specification is furnished under a license or nondisclosure agreement, and may be used or copied only in accordance with the terms of such agreement.

ELAN Microelectronics products are not intended for use in life support appliances, devices, or systems. Use of ELAN Microelectronics product in such applications is not supported and is prohibited.

NO PART OF THIS SPECIFICATION MAY BE REPRODUCED OR TRANSMITTED IN ANY FORM OR BY ANY MEANS WITHOUT THE EXPRESSED WRITTEN PERMISSION OF ELAN MICROELECTRONICS.



ELAN MICROELECTRONICS CORPORATION

Headquarters:

No. 12, Innovation Road 1
Hsinchu Science Park
Hsinchu, Taiwan 30077
Tel: +886 3 563-9977
Fax: +886 3 563-9966
<http://www.emc.com.tw>

Hong Kong:

Elan (HK) Microelectronics Corporation, Ltd.
Rm. 1005B, 10/F Empire Centre
68 Mody Road, Tsimshatsui
Kowloon, HONG KONG
Tel: +852 2723-3376
Fax: +852 2723-7780
elanhk@emc.com.hk

USA:

Elan Information Technology Group
1821 Saratoga Ave., Suite 250
Saratoga, CA 95070
USA
Tel: +1 408 366-8223
Fax: +1 408 366-8220

Europe:

Elan Microelectronics Corp. (Europe)
Siewerdtstrasse 105
8050 Zurich, SWITZERLAND
Tel: +41 43 299-4060
Fax: +41 43 299-4079
<http://www.elan-europe.com>

Shenzhen:

Elan Microelectronics Shenzhen, Ltd.
SSMEC Bldg., 3F, Gaoxin S. Ave.
Shenzhen Hi-Tech Industrial Park
Shenzhen, Guangdong, CHINA
Tel: +86 755 2601-0565
Fax: +86 755 2601-0500

Shanghai:

Elan Microelectronics Shanghai Corporation, Ltd.
23/Bldg. #115 Lane 572, Bibo Road
Zhangjiang Hi-Tech Park
Shanghai, CHINA
Tel: +86 021 5080-3866
Fax: +86 021 5080-4600

Contents

1	General Description	1
2	Features	1
3	Application	1
4	Pin Assignment	2
5	Pin Descriptions	2
6	Function Descriptions	2
6.1	Decoder Buffer	2
6.2	Power-on Reset and Self Test.....	3
6.3	Decoder Data Output	3
6.4	Decoder Data Input	3
6.5	Device ID.....	3
6.6	Command From the System	4
6.6.1	Set/Reset Status Indicators (Hex ED).....	4
6.6.2	Echo (Hex EE).....	4
6.6.3	Invalid commands (Hex EF and F1).....	4
6.6.4	Select Alternate Scan Code (Hex F0).....	4
6.6.5	Read ID (Hex F2).....	5
6.6.6	Set Typematic Rate/Delay (Hex F3).....	5
6.6.7	Enable (Hex F4)	6
6.6.8	Default Disable (Hex F5).....	6
6.6.9	Set Default (Hex F6).....	6
6.6.10	Set All Keys (Hex F7, F8, F9, FA).....	6
6.6.11	Set Key Type (Hex FB,FC,FD).....	7
6.6.12	Resend (Hex FE).....	7
6.6.13	Reset (Hex FF).....	7
6.7	Command to the System.....	7
6.7.1	Acknowledge (Hex FA).....	7
6.7.2	BAT Completion Code (Hex AA).....	7
6.7.3	BAT Failure Code (Hex FC)	7
6.7.4	Echo (Hex EE).....	7
6.7.5	Keyboards ID (Hex 83AB).....	8
6.7.6	Keyboard buffer Overrun (Hex 00 or FF)	8
6.7.7	Resend (Hex FE).....	8
7	Keyboard Scan Code Table	8
7.1	Scan Code Set 1	8
7.2	Scan Code Set 2	11
7.3	Scan Code Set 3	13
7.4	New key codes for scan set 1	15
7.5	New key codes for scan set 2	15
7.6	New Key codes for scan set 3.....	16



7.7	Windows 2000 Multi-Media key code.....	16
8	Absolute Maximum Ratings	17
9	DC Electrical Characteristics	17
10	AC Electrical Characteristics	17
11	Timing Diagrams	18
12	Application Circuit	19

PRELIMINARY

Specification Revision History

Doc. Version	Revision Description	Date
1.0	Preliminary version	2002/11/15

PRELIMINARY



PRELIMINARY

1 General Description

In RF keyboard system, that is divided into two parts (the transmitter and the receiver). The eKK6111 micro-controller is dedicated to RF keyboard decoder for single channel RF Rx module. The eKK6111 is decode the data from RF Rx module, control all scan codes, three LEDs status and communication with PC. That is specially designed for IBM PC AT and all compatible machines.

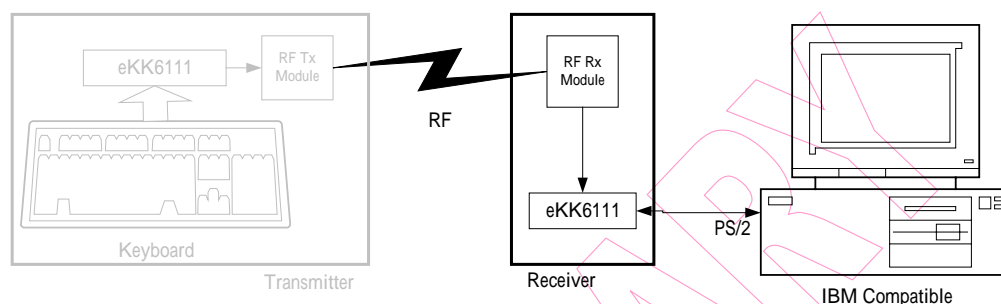

2 Features

- Low Cost – eliminate need external components
- Resonator Oscillator (4.00MHz)
- Support scan code set 1, 2 and 3
- Support PC AT and PS/2 keyboard
- Support WINDOWS 95, 98, 2000 keys.
- 104/107 Key with multi-media or other special application keyboard encoder.
- RF demodulation tolerance: $\pm 20\%$
- Using the device ID to identify which transmitter was connected.
 - DIP switch to select. (8 sets ID)
 - Random generate ID (255 sets ID) and store in EEPROM (93LC46)
- Package: 28-pins PDIP, 28-pins SOP

3 Application

- The eKK6111 is support the single channel or two channels RF Receiver module.
- IBM PC AT or compatible machine keyboard
- IBM PS/2 or compatible machine keyboard

4 Pin Assignment

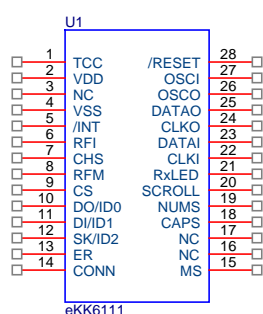

5 Pin Descriptions

Symbol	I/O	Function
P50	I	Connect with data pin of RF receiver module connection
P60	I	Switch DIP for Device ID bit 0 or connect with DO pin of EEPROM
P61	I / O	Switch DIP for Device ID bit 1 or connect with DI pin of EEPROM
P62	I / O	Switch DIP for Device ID bit 2 or connect with SK pin of EEPROM
P63	O	Connect with CS pin of EEPROM
P64	I	Connect with push bottom
P70	O	Caps Lock Indicator
P71	O	NUM Lock Indicator
P72	O	Scroll Lock Indicator
P73	O	RF data receive Indicator
P74	I	CLOCK line for IBM communication, internal pull high
P75	I	DATA line for IBM communication, internal pull high
P76	O	CLOCK line for IBM communication, internal open-drain
P77	O	DATA line for IBM communication, internal open-drain
OSCI	I	Connect with 4.00MHz resonator oscillation
OSCO	O	CLOCK Output
VDD	I	+5V Power supply
VSS	I	Ground

6 Function Descriptions

6.1 Decoder Buffer

The decoder will buffer 16 bytes in first-in-first-out order when the system is able to read scan codes from RF receiver module. The response codes and repeated codes will not be buffered. If receives a multiple-byte sequence, the entire sequence must fit into the buffer or the key data is discarded and a buffer-overflow condition occurs.

6.2 Power-on Reset and Self Test

The duration of the decoder Power-on-Reset (POR) should be within 150 milliseconds and 2 seconds after the power is applied to the decoder.

After executing POR, the receiver executes a self test. The LEDs are turned in at the beginning and off at the end of the self test. The self test takes a minimum 300 milliseconds and a maximum 500 milliseconds. If the self test is successful, A completion code AA hex is sent to the system and the decoder starts read and decode the data from RF Rx module. If self test fails, and error code is sent, the decoder is disabled and waits for command from the system. The completion codes are sent between 450 milliseconds and 2.5 seconds after POR, and between 300 and 500 milliseconds after RESET command is acknowledged.

6.3 Decoder Data Output

When the decoder is ready to send data to the system, it first checks clock and data lines. If either one is in the low state, data is stored in the buffer. If both are in the high state, decoder starts clocking data out. Data will be valid before the trailing edge and after the leading edge of the clock pulse. During the transmissions the decoder checks the clock line at least 60 microseconds. If the system lowers the clock lines before leading edge of the 10th clock, the decoder should stop sending, then buffer the data and return clock and data to high state.

6.4 Decoder Data Input

When the system is ready to send data to the decoder, it first checks line to see if decoder is sending data. If decoder is not sending data or it is sending data but has not reached the 10th clock, the system can inhibit the interface by forcing the clock line low for more than 60 microseconds and prepares to send data. The decoder checks clock line status at least every 5 milliseconds. If a system Request to Send (RTS) is detected, the decoder clocks 11 bits in. After 10th bit, the decoder checks for high state in data line then pulls it low and clocks one more bit to signal the system that data has been received. If data is low after the 10th bit, it indicates a frame error. The decoder should continue to count until data line goes high, then pulls it low and issues a RESEND to the system.

6.5 Device ID

The EM83110A has support two device ID mode:

- Controllable ID mode: Using the 3 bits DIP switch to control the device ID.
- Random generate ID mode: Using the push bottom to entry the device ID set mode. The EM83110A will receives 10 seconds the new device ID after push bottom pressed. When PC reset, the device ID will recovery from EEPROM.

6.6 Command From the System

The system can send commands to the decoder at any time. The decoder needs to respond within 20 milliseconds, unless the system prevents decoder output, when doing self test or executing a RESET. The following are the decoder input commands and the actions that the decoder needs to take.

6.6.1 Set/Reset Status Indicators (Hex ED)

Responds ACK.

Receives option byte.

Responds ACK.

Updates status indicators.

Return to previous scanning state.

6.6.2 Echo (Hex EE)

Responds with EE hex.

Returns to previous scanning state.

6.6.3 Invalid commands (Hex EF and F1)

Responds with EE hex.

Returns to previous scanning state.

6.6.4 Select Alternate Scan Code (Hex F0)

Responds ACK.

Clears output buffer.

Sets the default typematic rate/delay.

Clears last typematic key.

Receives options key.

Responds ACK.

Option byte =

01: selects scan code set 1

02: selects scan code set 2

03: selects scan code set 3

Returns to previous scanning state.

6.6.5 Read ID (Hex F2)

Responds with ACK.
Discontinues scanning.
Sends two ID Bytes. The second byte will be sent within 500 μ S after first byte.
Resumes scanning.

6.6.6 Set Typematic Rate/Delay (Hex F3)

Responds ACK.
Receives rate/delay value byte.
Responds ACK.
Set rate/delay (* Note1)
Returns to previous scanning state.

NOTE

1 Repeat period = $(8+A) \times (2B) \times 0.00417$ seconds
A binary value of bits 2, 1, and 0
B binary value of bits 4 and 3

2 Delay = $(C+1) \times 250$ milliseconds
C binary value of bits 6 and 5. Bit 7 is always 0

bit 4 ~ bit 0	Typematic rate \pm 20%	bit 4 ~ bit 0	Typematic rate \pm 20%
00000	30.0	10000	7.5
00001	26.7	10001	6.7
00010	24.0	10010	6.0
00011	21.8	10011	5.5
00100	20.0	10100	5.0
00101	18.5	10101	4.6
00110	17.1	10110	4.3
00111	16.0	10111	4.0
01000	15.0	11000	3.7
01001	13.3	11001	3.3
01010	12.0	11010	3.0
01011	10.9	11011	2.7
01100	10.0	11100	2.5
01101	9.2	11101	2.3
01110	8.6	11110	2.1
01111	8.0	11111	2.0

3 default rate = 10.9 chars/sec \pm 20%
 Default delay = 500 mS \pm 20%

6.6.7 Enable (Hex F4)

Responds with ACK.
Clears output buffer.
Clears last typematic key.
Start scanning.

6.6.8 Default Disable (Hex F5)

Responds with ACK.
Reset all conditions to power-on state.
Clears output buffer.
Sets the default key type (scan code set 3 only)
Set the default typematic rate/delay.
Clears last typematic key.
Stops scanning.

6.6.9 Set Default (Hex F6)

Responds with ACK.
Resets all conditions to power-on state.
Clears output buffer.
Sets the default key type (scan code set 3 only)
Set the default typematic rate/delay.
Clears last typematic key.
Continues scanning.

6.6.10 Set All Keys (Hex F7, F8, F9, FA)

Responds ACK.
Clear output buffer.
Set all key type (affect only code set 3 operation).

F7 : Typematic

F8 : Make/Break

F9 : Make

FA : Typematic/Make/Break

Returns to previous scanning rate.

6.6.11 Set Key Type (Hex FB,FC,FD)

Responds ACK.

Clears output buffer.

Receives key ID byte

Responds ACK.

Sets key ID type (affect only scan code set 3 operation).

FB : Typematic

FC : Make/Break

FD : Make

Returns to previous scanning rate.

6.6.12 Resend (Hex FE)

Sends the previous output again. If the previous byte is RESEND, the last byte before RESEND shall be sent.

6.6.13 Reset (Hex FF)

Responds ACK.

Checks clock and data lines in the high state for at least 500 microseconds or receives another command.

Default to scan code set 2 .

6.7 Command to the System

The following are the keyboard output commands.

6.7.1 Acknowledge (Hex FA)

The keyboard sends an acknowledge in response to any valid command from the system except for RESEND and ECHO.

6.7.2 BAT Completion Code (Hex AA)

This command is issued after successful completion of keyboard self test.

6.7.3 BAT Failure Code (Hex FC)

If a BAT failure occurs, the keyboard sends this code , discontinues scanning, and waits for a system response or reset.

6.7.4 Echo (Hex EE)

The keyboard sends this code in response to an ECHO command.



6.7.5 Keyboards ID (Hex 83AB)

The 2 byte ID is issued to respond to READ ID command. The low byte is sent first, followed by the high byte.

6.7.6 Keyboard buffer Overrun (Hex 00 or FF)

If keyboard buffer overflows, the overrun code will replace the last byte in the buffer. If the keyboard is using scan code set 1 , the code is hex FF. For sets 2 and 3, the code is hex 00.

6.7.7 Resend (Hex FE)

When the keyboard receives an invalid input or any input with incorrect parity, the RESEND command is sent.

7 Keyboard Scan Code Table

The keyboard contains 3 scan code sets. The system defaults to scan set 2. but can be switched to set 1 or set 3 . The following tables show the key numbers and three scan code sets in hexadecimal values. All the keys are typemantics except for the pause key. When a key is pressed down, the make scan code is sent to the system. When the key is released, its break code is sent. If two or more keys are held down, only the last key pressed repeats at the typematic rate. Typematic operation stops when the last pressed key is released, even if other keys are being released or some other keys are still held down.

The following table shows three scan code sets used in the keyboard.

7.1 Scan Code Set 1

Key	Make code	Break code	Key	Make code	Break code
'(~)	29	A9	X	2D	AD
1	02	82	C	2E	AE
2	03	83	V	2F	AF
3	04	84	B	30	B0
4	05	85	N	31	B1
5	06	86	M	32	B2
6	07	87	, (<)	33	B3
7	08	88	. (>)	34	B4
8	09	89	/ (?)	35	B5
9	0A	8A	SHIFT_R	36	B6
0	0B	8B	CTRL_L	1D	9D
- (_)	0C	8C	ALT_L	38	B8
= (+)	0D	8D	SPACE	39	B9
Back Space	0E	8E	ALT_R	E0 38	E0 B8



Key	Make code	Break code	Key	Make code	Break code
Tab	0F	8F	CTRL_R	E0 1D	E0 9D
Q	10	90	NUM	45	C5
W	11	91	(7)	47	C7
E	12	92	(4)	4B	CB
R	13	93	(1)	4F	CF
T	14	94	(8)	48	C8
Y	15	95	(5)	4C	CC
U	16	96	(2)	50	D0
I	17	97	(0)	52	D2
O	18	98	(*)	37	B7
P	19	99	(9)	49	C9
[(])	1A	9A	(6)	4D	CD
] (])	1B	9B	(3)	51	D1
\ () @1	2B	AB	(DEL)	53	D3
Caps	3A	BA	(-)	4A	CA
A	1E	9E	(+)	4E	CE
S	1F	9F	(ENTER)	E0 1C	E0 9C
D	20	A0	ESC	01	81
F	21	A1	F1	3B	BB
G	22	A2	F2	3C	BC
H	23	A3	F3	3D	BD
J	24	A4	F4	3E	BE
K	25	A5	F5	3F	BF
L	26	A6	F6	40	C0
; (:)	27	A7	F7	41	C1
' (")	28	A8	F8	42	C2
K42 @2	2B	AB	F9	43	C3
ENTER	1C	9C	F10	44	C4
SHIFT_L	2A	AA	F11	57	D7
K45 @3	56	D6	F12	58	D8
Z	2C	AC	SCROLL	46	C6



Key	Base Case,or Shift + Nun Lock Make/Break @3	Shift Case Make/Break	Num Lock Make/Break
INS	E0 52 / E0 D2	E0 AA E0 52 / E0 D2 E0 2A	E0 2A E0 52 / E0 D2 E0 AA
DEL	E0 53 / E0 D3	E0 AA E0 53 / E0 D3 E0 2A	E0 2A E0 53 / E0 D3 E0 AA
LEFT	E0 4B / E0 CB	E0 AA E0 4B / E0 CB E0 2A	E0 2A E0 4B / E0 CB E0 AA
HOME	E0 47 / E0 C7	E0 AA E0 47 / E0 C7 E0 2A	E0 2A E0 47 / E0 C7 E0 AA
END	E0 4F / E0 CF	E0 AA E0 4F / E0 CF E0 2A	E0 2A E0 4F / E0 CF E0 AA
UP	E0 48 / E0 C8	E0 AA E0 48 / E0 C8 E0 2A	E0 2A E0 48 / E0 C8 E0 AA
DOWN	E0 50 / E0 D0	E0 AA E0 50 / E0 D0 E0 2A	E0 2A E0 50 / E0 D0 E0 AA
PAGE UP	E0 49 / E0 C9	E0 AA E0 49 / E0 C9 E0 2A	E0 2A E0 49 / E0 C9 E0 AA
PAGE DOWN	E0 51 / E0 D1	E0 AA E0 51 / E0 D1 E0 2A	E0 2A E0 51 / E0 D1 E0 AA
RIGHT	E0 4D / ED CD	E0 AA E0 4D / E0 CD E0 2A	E0 2A E0 4D / E0 CD E0 AA

Key	Scan Code Make/Break	Shift Case Make/Break @3
(/)	E0 35 / E0 B5	E0 AA E0 35 / E0 B5 E0 2A

Key	Scan Code Make/Break	Ctrl Case, Shift Case Make/ Break	Alt Case Make/Break
PRINT	E0 2A E0 37 / E0 B7 E0 AA	E0 37 / E0 B7	54 / D4

Key	Make Code	Ctrl Key Pressed
PAUSE @4	E1 1D 45 E1 9D C5	E0 46 E0 C6

NOTE

@1 : 101-key keyboard only.

@2 : 102-key keyboard only.

@3 : If the left Shift key is held down, the AA/2A shift make and break is sent with the other scan codes. If the right Shift key is held down, B6/36 is sent. If both Shift keys are down, both sets of codes are sent with the other scan code.

@4 : This key is not typematic. All associated scan codes occur on the make of the key.



7.2 Scan Code Set 2

Key	Make code	Break code	Key	Make code	Break code
'(~)	0E	F0 0E	X	22	F0 22
1	16	F0 16	C	21	F0 21
2	1E	F0 1E	V	2A	F0 2A
3	26	F0 26	B	32	F0 32
4	25	F0 25	N	31	F0 31
5	2E	F0 2E	M	3A	F0 3A
6	36	F0 36	, (<)	41	F0 41
7	3D	F0 3D	. (>)	49	F0 49
8	3E	F0 3E	/ (?)	4A	F0 4A
9	46	F0 46	SHIFT_R	59	F0 59
0	45	F0 45	CTRL_L	14	F0 14
- (_)	4E	F0 4E	ALT_L	11	F0 11
= (+)	55	F0 55	SPACE	29	F0 29
Back Space	66	F0 66	ALT_R	E0 11	E0 F0 11
Tab	0D	F0 0D	CTRL_R	E0 14	E0 F0 14
Q	15	F0 15	NUM	77	F0 77
W	1D	F0 1D	(7)	6C	F0 6C
E	24	F0 24	(4)	6B	F0 6B
R	2D	F0 2D	(1)	69	F0 69
T	2C	F0 2C	(8)	75	F0 75
Y	35	F0 35	(5)	73	F0 73
U	3C	F0 3C	(2)	72	F0 72
I	43	F0 43	(0)	70	F0 70
O	44	F0 44	(*)	7C	F0 7C
P	4D	F0 4D	(9)	7D	F0 7D
[(f)	54	F0 54	(6)	74	F0 74
] (})	5B	F0 5B	(3)	7A	F0 7A
\ () @5	5D	F0 5D	(DEL)	71	F0 71
Caps	58	F0 58	(-)	7B	F0 7B
A	1C	F0 1C	(+)	79	F0 79
S	1B	F0 1B	(ENTER)	E0 5A	E0 F0 5A
D	23	F0 23	ESC	76	F0 76
F	2B	F0 2B	F1	05	F0 05
G	34	F0 34	F2	06	F0 06
H	33	F0 33	F3	04	F0 04
J	3B	F0 3B	F4	0C	F0 0C
K	42	F0 42	F5	03	F0 03
L	4B	F0 4B	F6	0B	F0 0B
; (:)	4C	F0 4C	F7	83	F0 83
' (")	52	F0 52	F8	0A	F0 0A
K42 @6	5D	F0 5D	F9	01	F0 01
ENTER	5A	F0 5A	F10	09	F0 09
SHIFT_L	12	F0 12	F11	78	F0 78
K45 @6	61	F0 61	F12	07	F0 07
Z	1A	F0 1A	SCROLL	7E	F0 7E



Key	Base Case, or Shift + Nun Lock Make/Break @7	Shift Case Make/Break	Num Lock Make/Break
INS	E0 70 / E0 F0 70	E0 F0 12 E0 70 / E0 F0 70 E0 12	E0 12 E0 70 / E0 F0 70 E0 F0 12
DEL	E0 71 / E0 F0 71	E0 F0 12 E0 71 / E0 F0 71 E0 12	E0 12 E0 71 / E0 F0 71 E0 F0 12
LEFT	E0 6B / E0 F0 6B	E0 F0 12 E0 6B / E0 F0 6B E0 12	E0 12 E0 6B / E0 F0 6B E0 F0 12
HOME	E0 6C / E0 F0 6C	E0 F0 12 E0 6C / E0 F0 6C E0 12	E0 12 E0 6C / E0 F0 6C E0 F0 12
END	E0 69 / E0 F0 69	E0 F0 12 E0 69 / E0 F0 69 E0 12	E0 12 E0 69 / E0 F0 69 E0 F0 12
UP	E0 75 / E0 F0 75	E0 F0 12 E0 75 / E0 F0 75 E0 12	E0 12 E0 75 / E0 F0 75 E0 F0 12
DOWN	E0 72 / E0 F0 72	E0 F0 12 E0 72 / E0 F0 72 E0 12	E0 12 E0 72 / E0 F0 72 E0 F0 12
PAGE UP	E0 7D / E0 F0 7D	E0 F0 12 E0 7D / E0 F0 7D E0 12	E0 12 E0 7D / E0 F0 7D E0 F0 12
PAGE DOWN	E0 7A / E0 F0 7A	E0 F0 12 E0 7A / E0 F0 7A E0 12	E0 12 E0 7A / E0 F0 7A E0 F0 12
RIGHT	E0 74 / E0 F0 74	E0 F0 12 E0 74 / E0 F0 74 E0 12	E0 12 E0 74 / E0 F0 74 E0 F0 12

Key	Scan Code Make/Break	Shift Case Make/Break @7
(/)	E0 4A / E0 F0 4A	E0 F0 12 E0 4A / E0 F0 4A E0 12

Key	Scan Code Make/Break	Ctrl Case, Shift Case Make/ Break	Alt Case Make/Break
PRINT	E0 12 E0 7C / E0 F0 7C E0 F0 12	E0 7C / E0 F0 7C	84 / F0 84

Key	Make Code	Ctrl Key Pressed
PAUSE @8	E1 14 77 E1 F0 14 F0 77	E0 7E E0 F0 7E

NOTE

@5 : 101-key keyboard only

@6 : 102-key keyboard only

@7 : If the left Shift key is held down, the F0 12/12 shift make and break is sent with the other scan codes. If the right Shift key is held down, F0 59/59 is sent. If both Shift keys are down, both sets of codes are sent with the other scan code.

@8 : This key is not typematic. All associated scan codes occur on the make of the key



7.3 Scan Code Set 3

Key	Make Code	Break Code	Default Key State
'(~)	0E	F0 0E	Typematic
1	16	F0 16	Typematic
2	1E	F0 1E	Typematic
3	26	F0 26	Typematic
4	25	F0 25	Typematic
5	2E	F0 2E	Typematic
6	36	F0 36	Typematic
7	3D	F0 3D	Typematic
8	3E	F0 3E	Typematic
9	46	F0 46	Typematic
0	45	F0 45	Typematic
-(_)	4E	F0 4E	Typematic
=(+)	55	F0 55	Typematic
Back Space	66	F0 66	Typematic
Tab	0D	F0 0D	Typematic
Q	15	F0 15	Typematic
W	1D	F0 1D	Typematic
E	24	F0 24	Typematic
R	2D	F0 2D	Typematic
T	2C	F0 2C	Typematic
Y	35	F0 35	Typematic
U	3C	F0 3C	Typematic
I	43	F0 43	Typematic
O	44	F0 44	Typematic
P	4D	F0 4D	Typematic
[(])	54	F0 54	Typematic
] ()	5B	F0 5B	Typematic
\ () @9	5C	F0 5C	Typematic
Caps	14	F0 14	Make/Break
A	1C	F0 1C	Typematic
S	1B	F0 1B	Typematic
D	23	F0 23	Typematic
F	2B	F0 2B	Typematic
G	34	F0 34	Typematic
H	33	F0 33	Typematic
J	3B	F0 3B	Typematic
K	42	F0 42	Typematic
L	4B	F0 4B	Typematic
; (:)	4C	F0 4C	Typematic
' (")	52	F0 52	Typematic
K42 @10	53	F0 53	Typematic
ENTER	5A	F0 5A	Typematic
SHIFT_L	12	F0 12	Make/Break
K45 @10	13	F0 13	Typematic
Z	1A	F0 1A	Typematic
X	22	F0 22	Typematic
C	21	F0 21	Typematic
V	2A	F0 2A	Typematic
B	32	F0 32	Typematic
N	31	F0 31	Typematic
M	3A	F0 3A	Typematic
, (<)	41	F0 41	Typematic
. (>)	49	F0 49	Typematic
/ (?)	4A	F0 4A	Typematic
SHIFT_R	59	F0 59	Make/Break
CTRL_L	11	F0 11	Make/Break
ALT_L	19	F0 19	Make/Break



Key	Make Code	Break Code	Default Key State
SPACE	29	F0 29	Typematic
ALT_R	39	F0 39	Make only
CTRL_R	58	F0 58	Make only
INS	67	F0 67	Make only
DEL	64	F0 64	Typematic
LEFT	61	F0 61	Typematic
HOME	6E	F0 6E	Make only
END	65	F0 65	Make only
UP	63	F0 63	Typematic
DOWN	60	F0 60	Typematic
PAGE UP	6F	F0 6F	Make only
PAGE DOWN	6D	F0 6D	Make only
RIGHT	6A	F0 6A	Typematic
NUM	76	F0 76	Make only
(7)	6C	F0 6C	Make only
(4)	6B	F0 6B	Make only
(1)	69	F0 69	Make only
(/)	77	F0 77	Make only
(8)	75	F0 75	Make only
(5)	73	F0 73	Make only
(2)	72	F0 72	Make only
(0)	70	F0 70	Make only
(*)	7E	F0 7E	Make only
(9)	7D	F0 7D	Make only
(6)	74	F0 74	Make only
(3)	7A	F0 7A	Make only
(DEL)	71	F0 71	Make only
(-)	84	F0 84	Make only
(+)	7C	F0 7C	Typematic
(ENTER)	79	F0 79	Make only
ESC	08	F0 08	Make only
F1	07	F0 07	Make only
F2	0F	F0 0F	Make only
F3	17	F0 17	Make only
F4	1F	F0 1F	Make only
F5	27	F0 27	Make only
F6	2F	F0 2F	Make only
F7	37	F0 37	Make only
F8	3F	F0 3F	Make only
F9	47	F0 47	Make only
F10	4F	F0 4F	Make only
F11	56	F0 56	Make only
F12	5E	F0 5E	Make only
PRINT	57	F0 57	Make only
SCROLL	5F	F0 5F	Make only
PAUSE	62	F0 62	Make only

NOTE

@9 : 101-key keyboard only

@10 : 102-key keyboard only

7.4 New key codes for scan set 1

New Key	Make	Break
WIN_L	E0 5B	E0 DB
WIN_R	E0 5C	E0 DC
APP	E0 5D	E0 DD
N-CHG (131)	7B	FB
CHG (132)	79	F9
ROMA (133)	70	F0
K14	7D	FD
K56	73	F3
K107	7e	FE
KL	F1	X
KR	F0	X
POWER	E0 5E	E0 DE
SLEEP	E0 5F	E0 DF
WAKE UP	E0 63	E0 E3

7.5 New key codes for scan set 2

New Key	Make	Break
WIN_L	E0 1F	E0 F0 1F
WIN_R	E0 27	E0 F0 27
APP	E0 2F	E0 F0 2F
N-CHG (131)	67	E0 67
CHG (132)	64	E0 64
ROMA (133)	13	E0 13
K14	6A	E0 6A
K56	51	E0 51
K107	6D	E0 6D
KL	F1	X
KR	F2	X
POWER	E0 37	E0 F0 37
SLEEP	E0 3F	E0 F0 3F
WAKE UP	E0 5E	E0 F0 5E



7.6 New Key codes for scan set 3

New Key	Make	Break	
WIN_L	8B	F0 8B	Make/break
WIN_R	8C	F0 8C	Make/break
APP	8D	F0 8D	Make/break
N-CHG (131)	85	F0 85	Make
CHG (132)	86	F0 86	Make
ROMA (133)	87	F0 87	Make
K14	5D	F0 5D	Typematic
K56	51	F0 51	Typematic
K107	7B	F0 7B	Typematic
KL	F1	X	
KR	F2	X	
POWER	X	X	
SLEEP	X	X	
WAKE UP	X	X	

7.7 Windows 2000 Multi-Media key code.

		SET1		SET2	
		MAKE	BREAK	MAKE	BREAK
K130	WWW Back	E0 6A	E0 EA	E0 38	E0 F0 38
K131	WWW Forward	E0 69	E0 E9	E0 30	E0 F0 30
K132	WWW Stop	E0 68	E0 E8	E0 28	E0 F0 28
K133	WWW Refresh	E0 67	E0 E7	E0 20	E0 F0 20
K134	WWW Search	E0 65	E0 E5	E0 10	E0 F0 10
K135	WWW Favorites	E0 66	E0 E6	E0 18	E0 F0 18
K136	WWW Web/Home	E0 32	E0 B2	E0 3A	E0 F0 3A
K137	Mail	E0 6C	E0 EC	E0 48	E0 F0 48
K138	Mute	E0 20	E0 A0	E0 23	E0 F0 23
K139	Volume-	E0 2E	E0 AE	E0 21	E0 F0 21
K140	Volume+	E0 30	E0 B0	E0 32	E0 F0 32
K141	Play/Pause	E0 22	E0 A2	E0 34	E0 F0 34
K142	Stop	E0 24	E0 A4	E0 3B	E0 F0 3B
K143	PreTrack	E0 10	E0 90	E0 15	E0 F0 15
K144	NextTrack	E0 19	E0 99	E0 4D	E0 F0 4D
K145	Media Select	E0 6D	E0 ED	E0 50	E0 F0 50
K146	MyComputer	E0 6B	E0 EB	E0 40	E0 F0 40
K147	Calculator	E0 21	E0 A1	E0 2B	E0 F0 2B

8 Absolute Maximum Ratings

Parameter	Symbol	Ratings
Temperature under bias	TOPR	0 to 70
Storage temperature	TSTR	-65 to 150
Input Voltage	VIN	-0.3V to +6V
Output Voltage	VOUT	-0.3V to +6V

9 DC Electrical Characteristics

Symbol	Parameter	Condition	Min.	Typ.	Max.	Unit
IIL	Input Leakage current	VIN=VDD, VSS			±1	mA
VIH	Input High Voltage	Ports 5,6	2.0			V
VIL	Input Low Voltage	Ports 5,6			0.8	V
VIHT	Input high threshold voltage	/RESET, TCC, INT	2.0			V
VILT	Input low threshold voltage	/RESET, TCC, INT			0.8	V
VIHX	Clock Input High voltage	OSCI	3.5			V
VILX	Clock Input Low voltage	OSCI			1.5	V
VOH1	Output High voltage (Ports 5,6,7)	IOH=-10.0mA	2.4			V
VOL1	Output Low Voltage (Ports 5,6)	IOL=9.0mA			0.4	V
VOL2	Output Low voltage (Ports 7)	IOL=14.0mA			0.4	V
IPH	Pull-high current	Pull-high active, input pin at VSS	-50	-100	-240	µA
ISB1	Power-down current	All input and I/O pins at VDD, output pin floating, WDT enabled			7	µA
ICC1	Operating supply current (VDD=5.0V) at two cycles/two clocks	/RESET=High, Fosc=4.00Mhz (HLF="1", CK2="0"), output pin floating, WDT enabled			5	mA

10 AC Electrical Characteristics

Parameter	Sym.	Min.	Typ.	Max.	Unit.
Time from DATA transition to falling edge of CLK	T1	5		25	µS
Time from rising of CLK to DATA transition	T2	5		T4-5	µS
Duration of CLK inactive	T3	30	40	50	µS
Duration of CLK active	T4	30	40	50	µS
Time to auxiliary device inhibit after clock 11 to ensure the auxiliary device does not start another transmission	T5			50	µS
Time from inactive to active CLK transition, used to time when auxiliary device sample DATA	T6	5		25	µS
System clock	FCLK		4.00		Mhz

11 Timing Diagrams

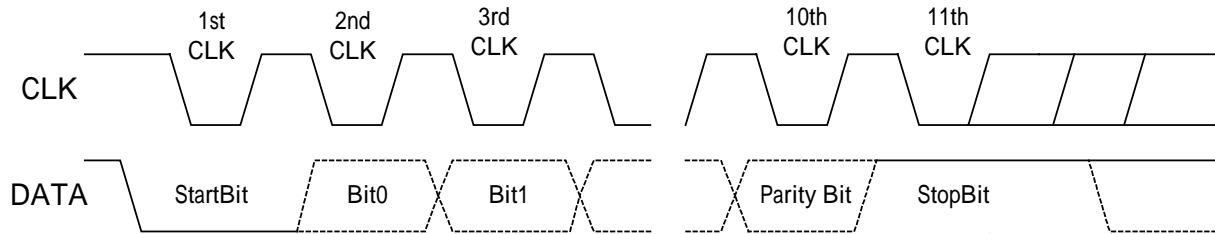

Fig.1 Keyboard output data timings

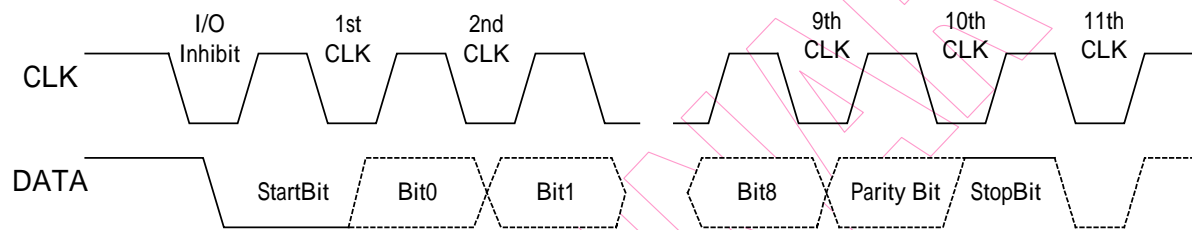

Fig.2 Keyboard input data timing

12 Application Circuit

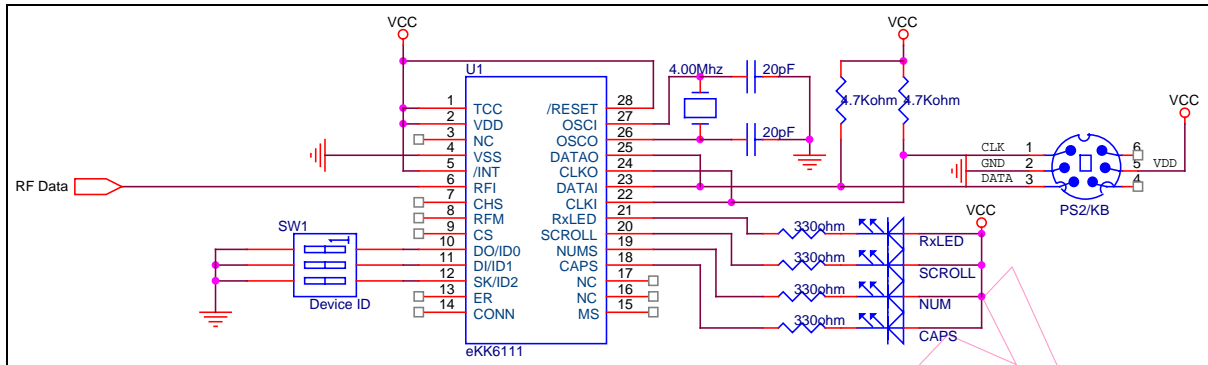

Fig.1 DIP Switch ID mode

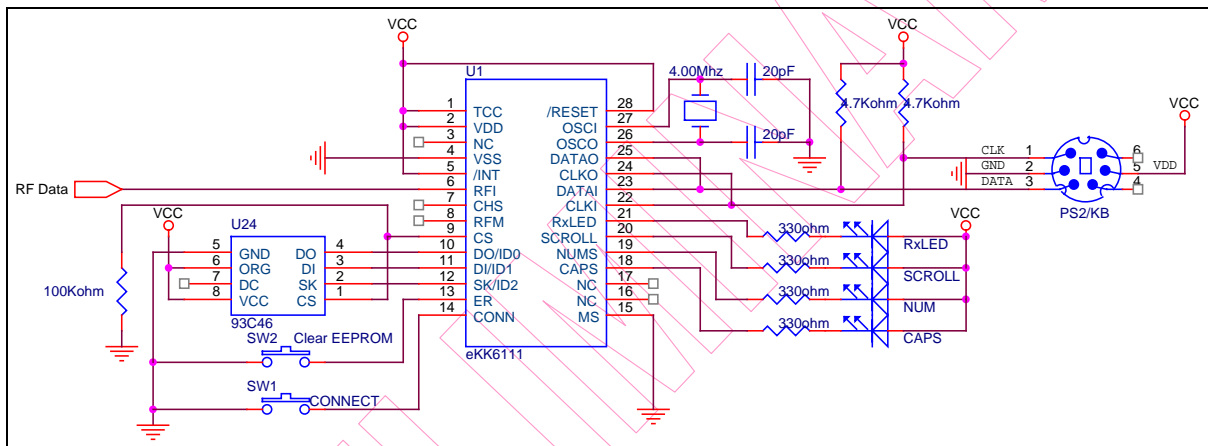

Fig.2 EEPROM ID mode



PRELIMINARY