



## Preliminary

### GENERAL DESCRIPTION

The EM91865 are 13 memory tone/pulse switchable dialer with Last Number Redial (LNB) and SAVE function, which are fabricated in CMOS technology with wide operating voltage for both tone and pulse mode. EM91865 consumes very low memory retention current in on hook state. The EM91865 provide necessary functions of telephone set for application in any environment, such as pulse dialing, tone (DTMF) dialing, handfree dialing. Besides this, hold, mute and redial function are provided for particular operation. In redial mode EM91865 can auto insert pause time for application in PABX system. EM91865 also have a special I/O pin -  $\overline{VAO}$  can be used to control the receive volume amplify circuit.

### FEATURES

- Volume add Control Function.
- One key Redial Function.
- Flash key is available and have multiple Flash time ( 600 ms, 300 ms, 100 ms ) can be selected.
- Auto Insert Pause Time.
- Tone/Pulse Switchable.
- Pulse mode fixed 10PPS.
- Pulse to tone ( P→T ) key is provided for PABX operation.
- Many options can be selected by R option.
  - Mode ( Pulse, Tone )
  - M/B ratio ( 40:60 ; 33:66 )
  - Auto insert pause time ( enable ; disable )
- 13 sets 16 digits one touch memory, or 3 set one touch and ten set two touch 16 digits memory.
- One set 32 digits SAVE function.
- One set 32 digits LNB redial function.
- Mixed and cascaded dialing.
- Hold and Mute function.
- Hand Free dialing.
- Tone duration and inter -tone pause are fixed at 90 ms.
- Flash pause time are fixed at 600 ms.
- Pulse to Tone pause time are fixed at 3.6sec.
- Uses 3.579545 MHz crystal or ceramic resonator (with built-in capacitor, no need extra capacitor).
- Package in DIP 18 or DIP 16.

#### Total System

- Operating voltage : 2.0V ~ 5.5V
- Operating current : Tone mode 0.3 mA (typical) ~ 0.5 mA  
Pulse mode 0.15 mA (typical) ~ 0.2 mA
- Standby current : 0.01 uA ( typical ) 0.1 uA ( max. )
- Use single clock 3.579545 MHz crystal



**Preliminary**

**PIN ASSIGNMENTS**

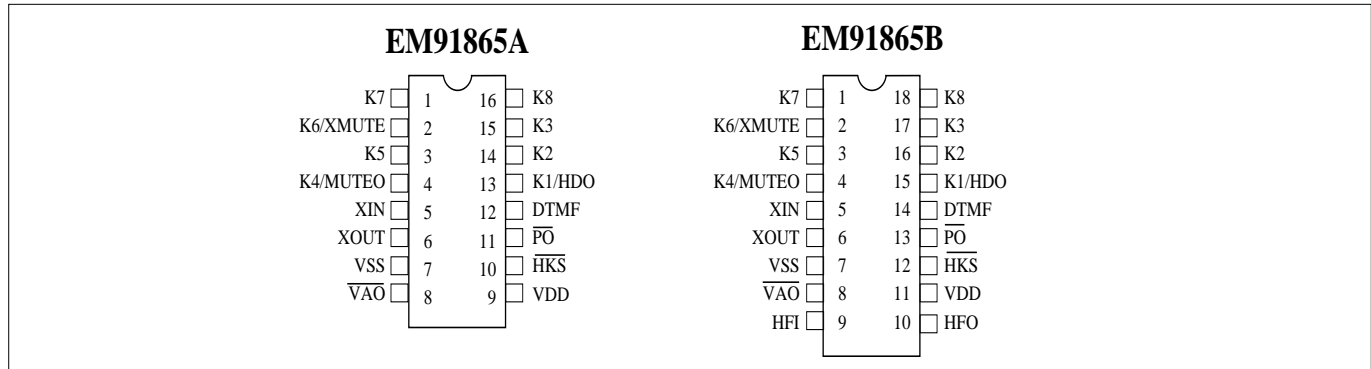

**PIN DESCRIPTIONS**

Symbol	Function
K2 , K3 , K5 ~ K8 I/O pin	Key board scan I/O pins, key scans by ripple way. These pins output 16K Hz signal one by one and periodically for key board scan.
K1/HDO	This pin has two functions Normally this pin will be a Key board scan pins function same as K1~K8. In Hold condition this pin will stay in "High" level to control the Hold circuit and scan HD input key. In Hold condition all key will not allow keying except HD, HF and Hook switch.
K4/MuteO	This pin has two functions Normally this pin will be a Key board scan pins function same as K1~K8. In MUTE condition this pin will stay in "High" level and output signal with the inverse of key scan to control the MUTE circuit and scan input key. Any key input will release MUTE condition.
K6/XMUTE	This pin has two functions Normally this pin will be a Key board scan pins function same as K1~K8. The Tone/Pulse dialing Mute signal output pin. This pin will switch to "High" level during Tone/Pulse dialing and hold function. Otherwise, this pin DC level stays "Low".
VDD, VSS	Positive and negative power supply input pin
Xin, Xout	Oscillator input and output pins, built in two 5pf capacitor so it's not need external capacitor. A 3.579545 MHz crystal must be crossed between Xin and Xout.
HFI	Handfree function Input pin accepts rising edge signal to turn "on" or turn "off" handfree function. This pin is hysteresis input structure and built-in pull down resistor (typically 200 KΩ) .
HFO	Handfree outputs pin that is designed to control telephone line for on-hook dialing or control speakerphone circuit for handfree conversation. When handfree function is executed, this pin will switch to "High". Otherwise, this pin stays "Low" level.
HKS	Hook Switch detects input pin, which is hysteresis input structure and without internal pull up resistor.
DTMF	DTMF (Dual Tone Multi-Frequency) output pin, In tone dialing mode, this pin will output DTMF signal that is corresponding to key board 0~9, *, # key.
PO	Pulse signal output pin that is NMOS open-drain. This pin is for pulse dialing. This output is "Low" during pulse dialing blank duration and Flash operation active, otherwise will be "High impedance".
VAO	Volume Add output pin , which is open drain structure. Normally this pin will stay in "High Impedance". When Volume add active and dialer in OFF-HOOK mode operating then this pin will output "Low".

\* This specification are subject to be changed without notice.

## Preliminary

Key Assignment :

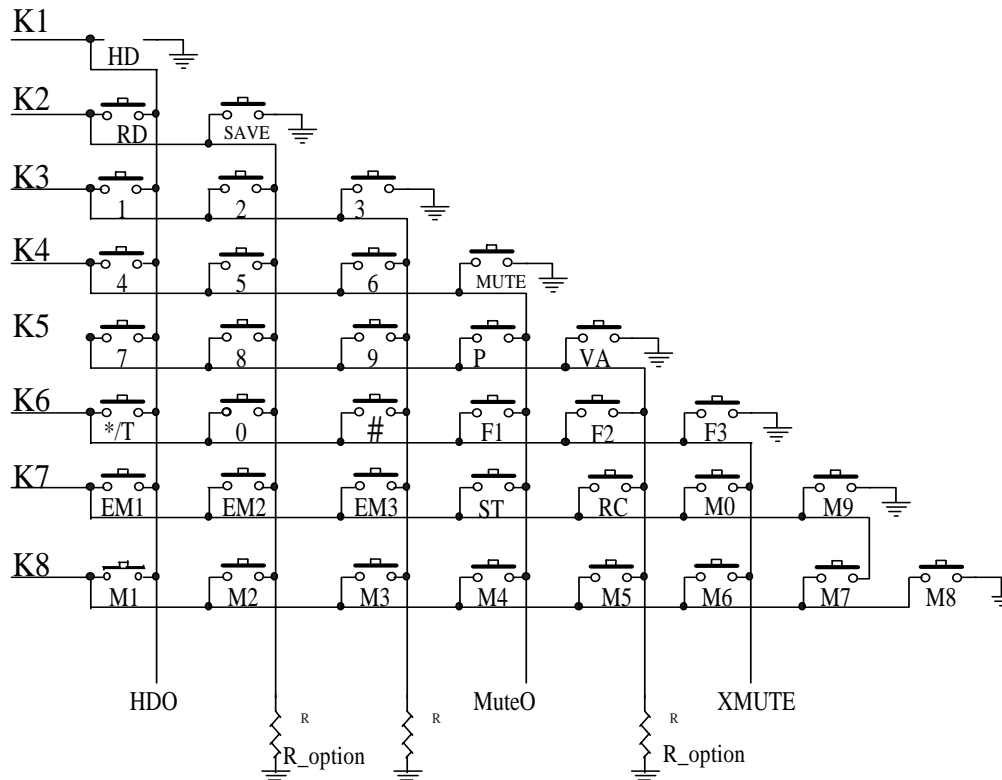

### KEYBOARD DESCRIPTION :

Key	Description
0~9, *, #	Digit key
F1, F2, F3	Flash key, flash time F1=600ms F2=300ms F3=100ms
*/T	In Pulse mode, this key mean Pulse to Tone function key
RD	Redial and One key Redial key
P	Pause key.
HD	Hold function key, at hold mode to key in "HD" key will go to idle On-hook state
HF	Handfree function key
SAVE	SAVE function key
ST	Store memory function key
EM1~EM3, M1~M10	One touch memory function key
RC	Recall key for two touch memory Recall
VA	Volume Add key.
MUTE	MUTE key. When this key be pressed MuteO output will be "high", and any key-in will release mute.



**Preliminary**

**FUNCTION DESCRIPTIONS**

**Dialer Option selection**

The EM91865 incorporated a special keyboard scanning function that is connecting a resistor ( typically is 560 K $\Omega$  ) on keyboard scan pin to select many telephone specifications.

**The specifications are described as follow :**

**a. M/B ratio**

K2	M/B ratio
NR	40:60
R-V <sub>SS</sub>	33:66

**b. Auto Insert Pause time**

K3	Auto Insert Pause time
NR	Disable
R-V <sub>SS</sub>	Enable

**d. Mode**

K5	Mode
NR	Tone
R-V <sub>SS</sub>	Pulse

Normal Dialing :

Press the digital key directly on keyboard which number can be dialing out and stored in LNB memory automatically. Operating procedure described as following:

- To select Pulse or Tone mode.
- Off-Hook or turn on HF function.
- Keying d1,d2,...dn. The "d" expressed digital key pressed that include 1~9, \*, 0, #, P, and P→T keys. The "n" expressed unlimited.
- The numbers d1,d2,....., dn will be dialed out in Pulse or Tone mode as selection.

**LNB Redial Function :**

**Storing :**

In normal dialing mode, every digital key was entry which number will be stored in LNB memory automatically. If entry digits are more than 32 digits, the redial function of LNB memory will be disabled, otherwise, these numbers stored in LNB memory can be redial output.

**Redialing :**

EM91865 provide Redial and One Key Redial function

(1) Redial function

Off-Hook normal dialing directly keying "F" key (or ON-OFF Hook once) and key-in "RD" keyboard. The numbers stored in LNB memory will be dialed out.

(2) One Key Redial function

Off-Hook normal dialing, if busy, press the "RD" key directly then the line will be broken about 1.2 sec with Trp redial pause time and dial out the numbers stored in LNB memory automatically.

## Preliminary

### Auto Insert Pause Time Function

EM91865 Provides a new function - Auto Insert Pause Time function - for PABX system user. In PABX system, we usually use a special number to identify the phone want dial out or just a internal phone. So between the first and second number, the PABX system will switch to central office, that will be few second switch time. The auto insert pause time function will auto insert the pause time between first and second digit in redialing mode. This function are provide a pause time to wait PABX switch to Central Office. In fact, the pause time are record the waiting time of last dialing between the first and second digit. The auto insert pause minimum duration are equal 0 second, maximun duration are equal 3.5 second, and pause duration scale are 0.1 second. So, if the time during user keying first and second digit are longer than 3.5 seconds, the auto insert pause time will be limited at 3.5 second. By this function, we can redial the correct number out in PABX system. This function can select enable or disable by R\_option.

### Pause(P) key operation

The Pause(P) key is designed to support pause operation in dialing duration. "P" key can be stored in memory and it will occupy one digital position.

- To select Pulse or Tone mode.
- Off-hook(or turn on HF function), push (d1, d2,.....dn, P , k1, k2, ..... ,kn). These numbers will be dialed out as following sequence :

d1, d2,.....dn, Tp, k1, k2, ..... ,kn (Tp are the pause Time)

### SAVE redial memory

The SAVE memory is designed in EM91865 to support digits capacity buffer for second redial, pager, special memory for memo and other system applications.

Storing : EM91865 support two operating methods to store numbers into SAVE redial memory.

Method 1 :

- To select Pulse or Tone mode.
- Off-hook(or turn on HF function), push d1, d2 ..... , dn. The numbers d1, d2,...., dn will be dialed out in Pulse or Tone mode as selection.
- After dn had been dialed out and push [ST]. SAVE key. If the keying numbers are more than 32 digits that content of SAVE memory can not be updated. Otherwise, these numbers will be stored into SAVE memory.  
**Noted** : In the [ ] key allows to be omitted.
- SAVE buffer are the length 32 digits number.

Method 2 :

On or Off-hook (or turn on HF function), push ST, d1, d2 ..... , dn, [ST], SAVE. If the keying are not over 32 digits, the numbers d1, d2, ..... , dn will be stored in SAVE redial memory automatically.

Dialing

- To select Pulse or Tone mode.
- Off-hook (or turn on HF function or after executing Flash function), first push SAVE key. The numbers stored in SAVE memory will be dialed out in Pulse or Tone mode as selection.



## Preliminary

### One Touch memory :

The EM91865 incorporated 13 sets one touch memory each one can store numbers up to 16 digits. In memory storing, if stored numbers are more than 16 digits that only the previous 16 digits can be stored into specific memory.

Storing of 13 sets memory :

On-Hook or Off-Hook state, push (ST, d1, d2,.....di, [ST], EMn or Mn). The numbers d1, d2,.....di will be stored into memory location "n", the "n" expressed digital key from 1~3 for EM and 0~9 for M.

Dialing (after memory dialed out, the numbers of memory will copy to LNB) :

- To select Pulse or Tone mode.
- Off-hook (or turn on HF function), push EMn or Mn key. The memory content will be dialed out.

### Two Touch memory :

The EM91865 incorporated 10 sets two touch memory each one can store numbers up to 16 digits. In memory storing, if stored numbers are more than 16 digits that only the previous 16 digits can be stored into specific memory.

Storing of 10 sets two Touch memory :

On-Hook or Off-Hook state, push (ST, d1, d2,.....dn, ST, m). The numbers d1, d2,.....dn will be stored into memory location "Mm", the "m" expressed digital key from 0~9 map to M0~M9.

Dialing (after memory dialed out, the numbers of memory will copy to LNB) :

- To select Pulse or Tone mode.
- Off-hook(or turn on HF function), push(RC , m). The memory content in Mm will be dialed out.

### Cascade dialing :

Let EM1=1,2,3  
EM2=4,5,6  
EM3=7,8,9

At off-hook state, key in EM1, EM2, EM3, the LNB=1,2,3,4,5,6,7,8,9, and the number will be dialed out.  
The max. cascade dialing numbers are 32 digits.

### Mixing dialing :

Let LNB=7,8,9  
M2=4,5,6  
EM1=1,2,3

At off-hook state, key in "RD", EM1, \*, 0, P, ( A , 2 ), then the LNB=7,8,9,1,2,3,\*, 0, P,4,5,6, and the number will be dialed out.

### Pulse to Tone(\*T) key operation

The Pulse to Tone(\*T) key is designed to support toll dialing (long distance call) or PABX system operation. The "\*T" key can be stored in memory and it will be occupy one digital position.

- To select Pulse mode.
- Off-hook(or turn on HF function), push d1, d2,.....dn, \*/T, k1, k2, .....,kn. These numbers will be dialed out as following sequence :

## **Preliminary**

d1, d2, ..., dn, Tpt, k1, k2, ..., kn. (Tpt are the Pulse to Tone pause time)  
(pulse mode)                      (tone mode)

### **Flash(F=F1,F2,F3) key operation**

The Flash key is designed to break telephone line temporarily. After key is depressed, this dialer will send a flash signal to break line and reset all condition. The Flash's break time dependent on the which key be pressed, F1=600ms, F2=300ms, F3=100ms.

### **Handfree (HF) function**

The Handfree function are provided in advance version EM91865B to support on-hook dialing and loudspeaker application which can be turn "on" or "off" by pressed again "HF" key. During handfree function is executed, the HFO pin is switched to "high". Otherwise the HFO pin stays "low" level. One of the following operations can turn off Handfree function (HFO pin return to "Low").

- On-Off hook once.
- Pressed "HF" key
- Turn on Hold (HD) function.(HDO pin switched to "High")

### **Hold (HD) function**

The Hold function is designed to stop conversation temporarily. In off-hook state (or HF function is turned on), to press **HD** key on the keyboard, the Hold function can be turned "on" (HDO pin switched to "High"). One of the following operations can turn off Hold function (HDO pin switched to "Low").

- On-Off hook once.
  - To press HD key back to idle On\_Hook state
  - Turn on Handfree (HF) function.(HFO pin switched to "High")
- \*\* In Hold state all key board will be disable except "HF" , "HD" key and HKS switch

### **Mute function**

The EM91865 provide mute function to mute microphone or antler at off-hook (or turn on HF) state. When key-in "MUTE" key, "MuteO" pin will become "High" to mute microphone. Any key-in will release mute mode and operating the correct key.

### **Volume add function**

EM91865 provide Volume Add function to control the speech network for adding the receiving volume. Except idle On-Hook state, Volume add function will working effect no matter what state is. Volume add function are toggle structure. Every time touch VA key will inverter the VAO pin condition ( H→L→H→L→.....). So Volume add will active or release each time keying VA. If and only if, when dialer back to the idle On\_Hook state then the Volume add function will force to release. This solution protect the user will not be hurt by loud volume. Although Volume add state will not change by Off\_Hook or HF operation but if dialer are in HF mode then Volume add output (VAO) will be inhibited.

**Noted** : Except dialer back to idle state, any other operate will not reset volume add situation ( include HD, HF, Flash ..... , and so on ). So volume add situation will be hold until dialer back to idle.

**Preliminary**

**OPERATING FLOW CHART**

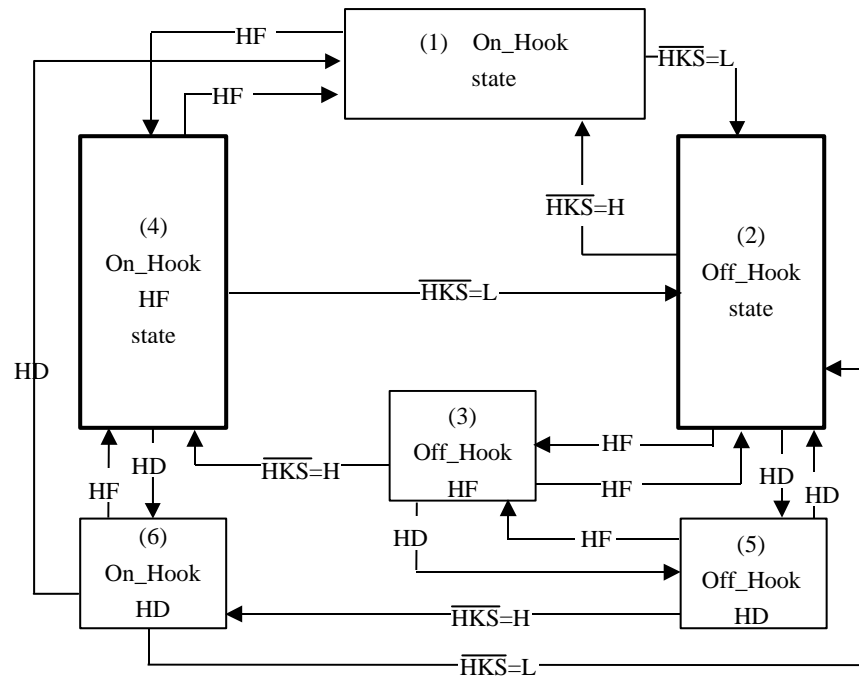

<Note> : HF=Handfree      HD=Hold

Truth Table :

Operating state	Input / Output pin level				
	$\overline{\text{HKS}}$	$\overline{\text{PO}}$	XMUTE	HFO	HDO
(1)On-hook, idle state	H	Z	L	L	L
(2)Off-hook line	L	Z	L	L	L
(3)Off-hook, HF line	L	Z	L	H	L
(4)On-hook, HF line	H	Z	L	H	L
(5)Off-hook, HD line	L	Z	H	L	H
(6)On-hook, HD line	H	Z	H	L	H

Note : Z= floating (high impedance) ; H= logic "High" ; L= logic "Low" level.

@ = To doing R-option





**Preliminary**

**ABSOLUTE MAXIMUM RATINGS**(Ambient temperature is 25°C, all voltages referenced to  $V_{SS}$ )

Items	Sym.	Rating	Unit
Power supply voltage	$V_{DD}$	6.0	V
Input voltage range	$V_{IN}$	$V_{SS}-0.3V \sim V_{DD}+0.3V$	V
Operating temperature	$T_{OPR}$	0 ~ +70	°C
Storage temperature	$T_{STO}$	-55 ~ 150	°C
Power consumption	$P_D$	500	mW

### RECOMMENDED OPERATING CONDITIONS

1. Supply voltage range from 2 V to 5.5 V at  $f_c=3.58$  MHz
2. Operation frequency: 3.58 MHz crystal.

### D.C. ELECTRICAL CHARACTERISTICS

( $V_{SS}=0V$ ;  $T_{OPR}=0^{\circ}C$  to  $70^{\circ}C$ ,  $V_{DD}=3V$  unless otherwise noted)

Parameter		Sym.	Min.	Typ.	Max.	Unit	Condition
Operating voltage	Tone	$V_{DD}$	2.0	-	5.5	V	unload
	Pulse		2.0	-	5.5		
	Memory retenion		1.0	-	5.5		
Standby current		Istby	-	0.001	0.1	$\mu A$	Idle On_Hook state
			-	0.15	0.3	mA	
Operating current	Tone	$I_{DD}$	-	0.3	0.5	mA	
	Pulse		-	0.15	0.3		
Memory retention current		Imrt	-	0.001	0.1	$\mu A$	HKS=1, Vdd=1V
HKS , HFI		ViH	0.7	-	1	$V_{DD}$	Schmitt trigger
Input voltage		ViL	$V_{SS}$	-	0.3		
HFO		IoH	-0.2	-	-	mA	$V_o=2.5V$
Drive current							
Sink current		IoL	0.2	-	-		$V_o=0.5V$
HFO pull down resistor		Rhf		-	200	-	$K\Omega$
VAO		IoH	-	-	-0.01	$\mu A$	$V_{xmute}=V_{dd}$
Leakage current							
Sink current		IoL	1	-	-	mA	$V_{xmute}=0.5V$
MuteO , HDO , XMUTE		IoH	-270	-350	-420	$\mu A$	$V_o=2.5V$
Drive current							
Sink current		IoL	10	20	50		$V_o=0.5V$
K2 , K3 , K6 , K7 , K8		IoH	-270	-350	-420	$\mu A$	$V_o=2.5V$
Output current		IoL	10	20	50		$V_o=0.5V$
PO Sink current		IoL	1	1.5	2	mA	$V_o=0.5V$



**Preliminary**

**DTMF CHARACTERISTICS** ( $V_{SS} = 0V$ ,  $V_{DD} = 3V$ ,  $T_{opr} = 0^{\circ}C$  to  $70^{\circ}C$ )

Symbol	Description	Min.	Typ.	Max.	Unit
Twist	Twist=20 LOG(COL/ROW)	1	2	3	dB
DC level	Vdc, Vdd=2.0V~5.5V	0.55	-	0.7	Vdd
Dist	Distortion	-	-30	-23	dB
Ac level	Row group	130	155	180	mVrms
Sink current	Vdtmf=0.5V	0.2	-	-	mA
Load resistor	Dist<-23dB	5	-	-	K $\Omega$
Minimum tone duration	Td (redial)	-	90	-	ms
Minimum intertone pause	Titp (redial)	-	90	-	ms

**ACTUAL FREQUENCY OUTPUT** ( $f_{osc} = 3.579545$  Hz)

	Standard (Hz)	Output (Hz)	Deviation (%)
F1	697	699	+0.28
F2	770	766	-0.52
F3	852	848	-0.47
F4	941	948	+0.74
F5	1209	1216	+0.57
F6	1336	1332	-0.30
F7	1477	1472	-0.34

**ELECTRICAL CHARACTERISTIC**

( $V_{DD} - V_{SS} = 3.0V$ ,  $f_{osc} = 3.58$  MHz)

Parameter	Sym.	Min.	Typ.	Max.	Unit	Condition
Keyin or release debounce	Tdb	-	18	-	ms	
Pulse rate	PSR	-	10	-	pps	
Make/Break ratio	MBR	-	40:60	-	%	K2 pin=NR
		-	33:66	-		K2 pin=R-Vss
Inter-digit pause time	Tidp	-	800	-	ms	
Pause time	Tp	-	3.6	-	S	
Pulse to tone time						
Flash break time	Tf	-	600	-	mS	F1 key
			300			F2 key
			100			F3 key
Flash Pause time	Tfp	-	600	-	mS	
Tone duration	Td	-	90	-	mS	
One key redial Break time	Trb	-	1.2	-	S	
One key redial Pause time	Trb	-	1	-	S	
Scan wave width	Tsw	-	1/32	-	mS	
Scan wave period	Tsp	-	0.25	-	mS	
Key board scan Period	Tksp	-	2.25	-	mS	
Auto Insert Pause	Taip	0	-	3100	mS	
Pre-Mute time	Tpm	-	5	-	mS	

\* This specification are subject to be changed without notice.

**Preliminary**

**TIMING DIAGRAM**

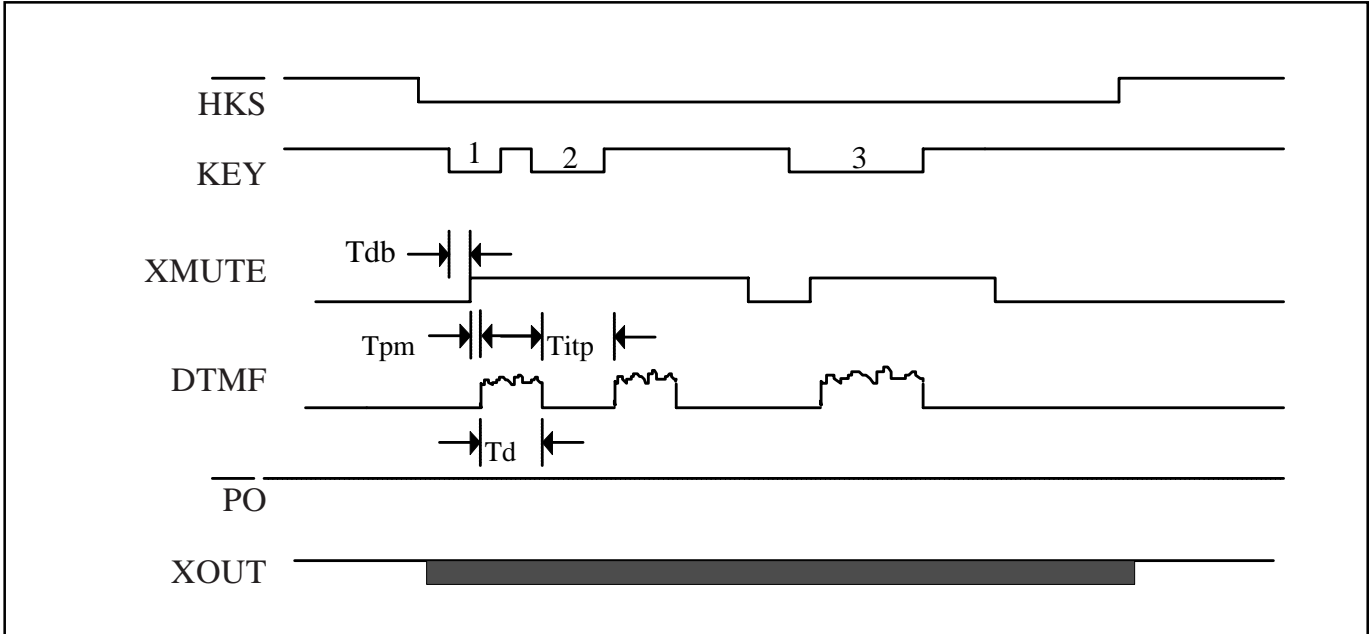

Figure 1. Tone Mode operating Timing

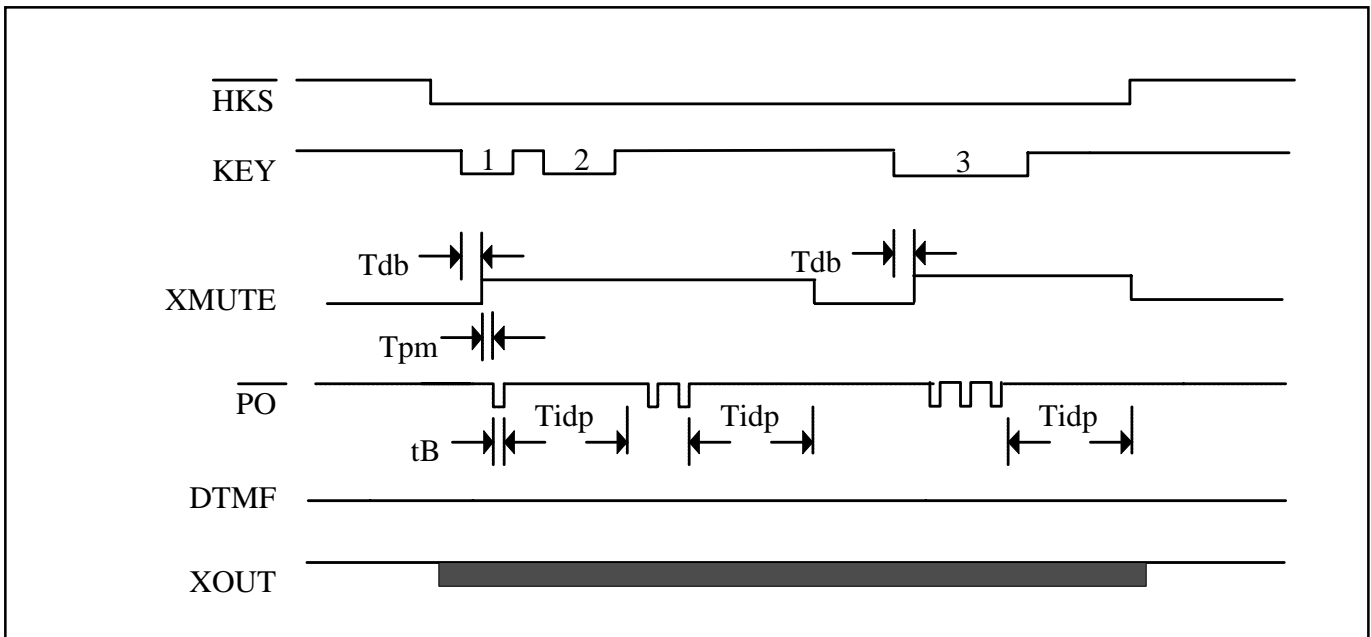

Figure 2. Pulse Mode operating Timing

**Preliminary**

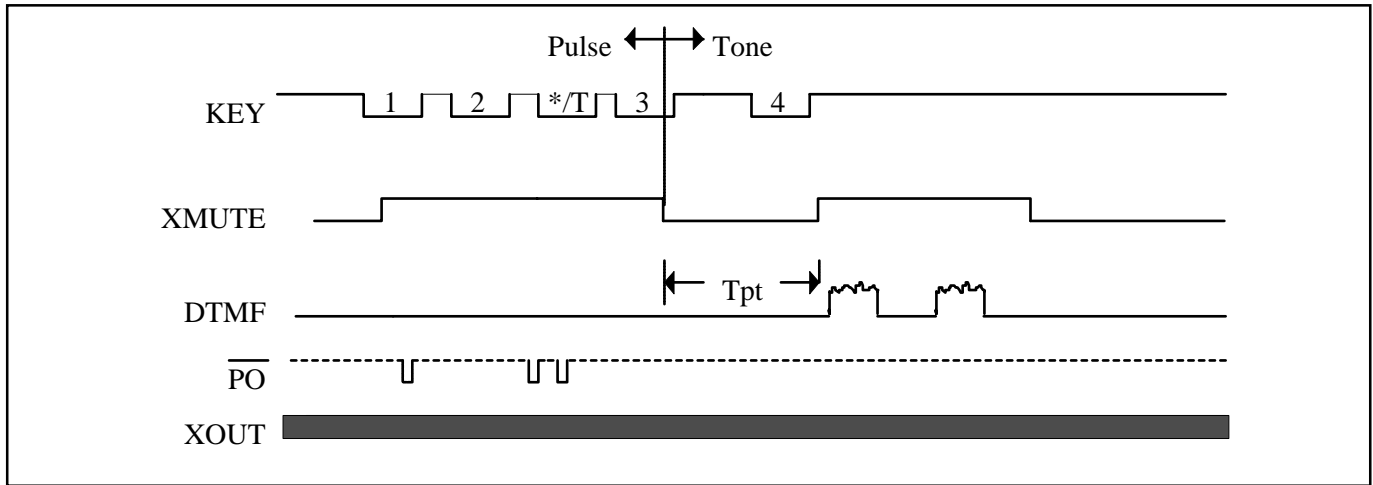

Figure 3. Pulse to Tone operating Timing

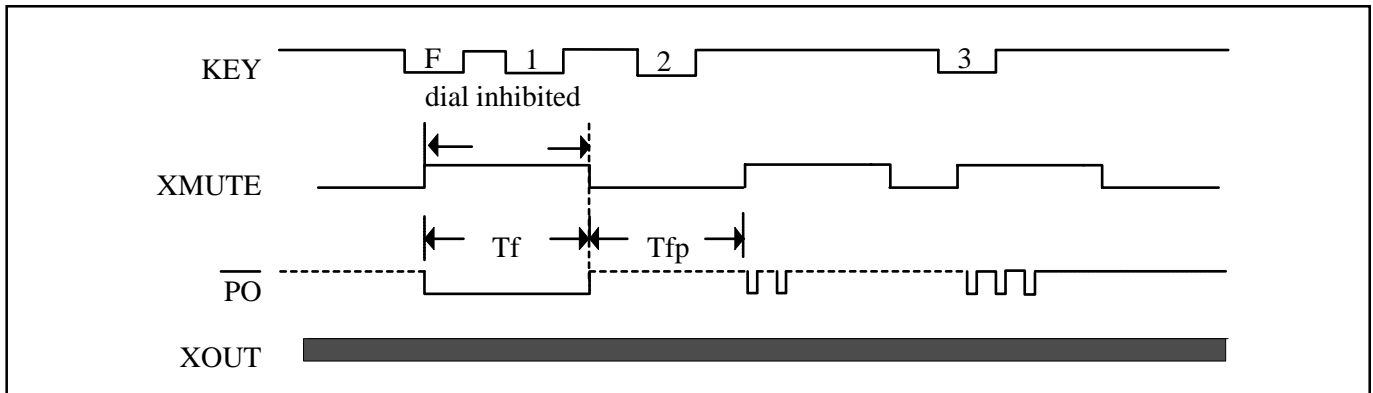

Figure 4. Flash operating Timing

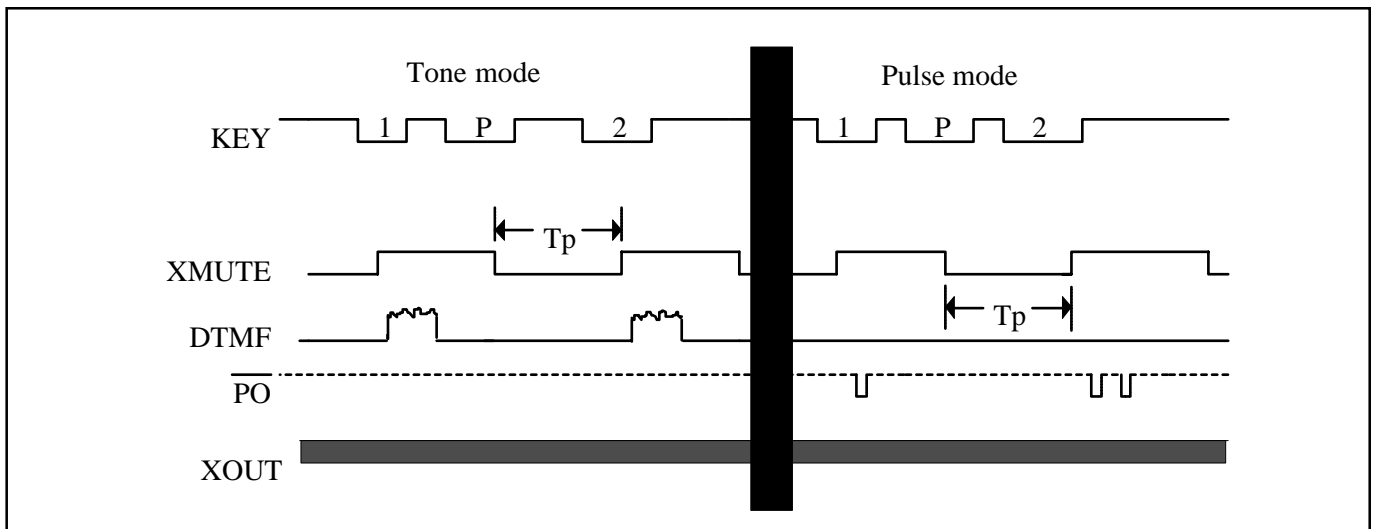

Figure 5. Pause operating Timing

**Preliminary**

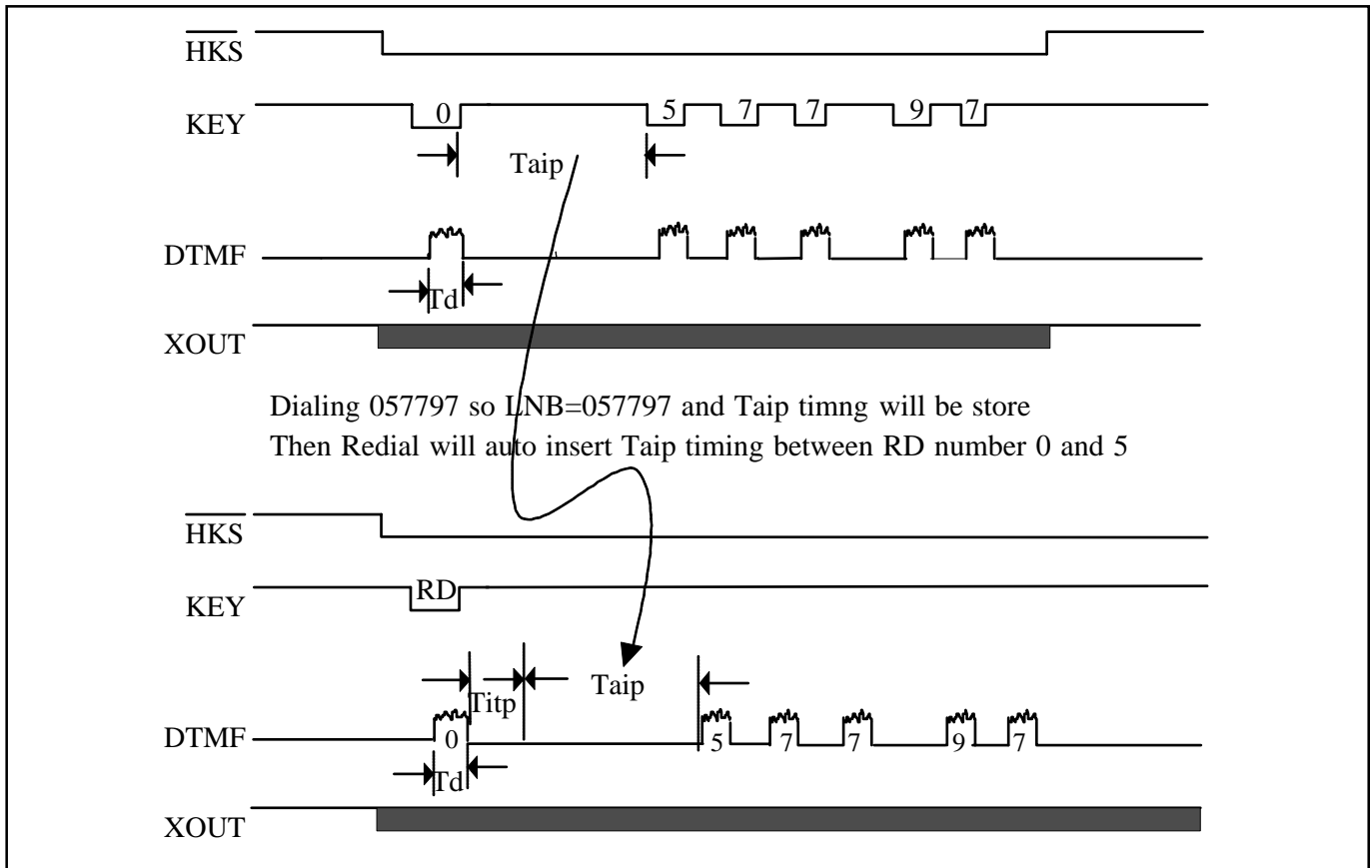

Figure 6. Auto Insert Time operating Timing

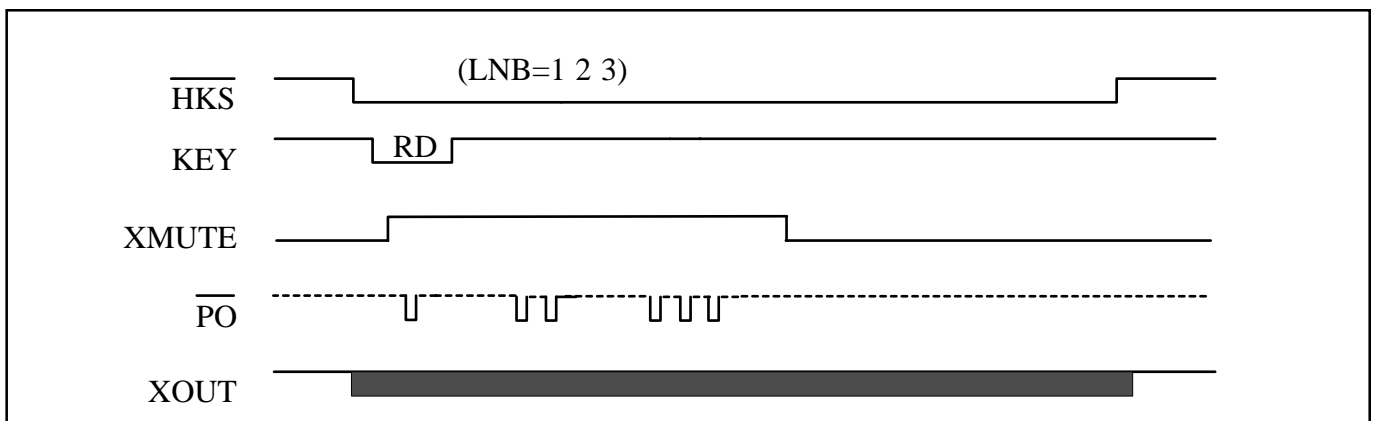

Figure 7. Redial operating Timing( Pulse Mode )

**Preliminary**

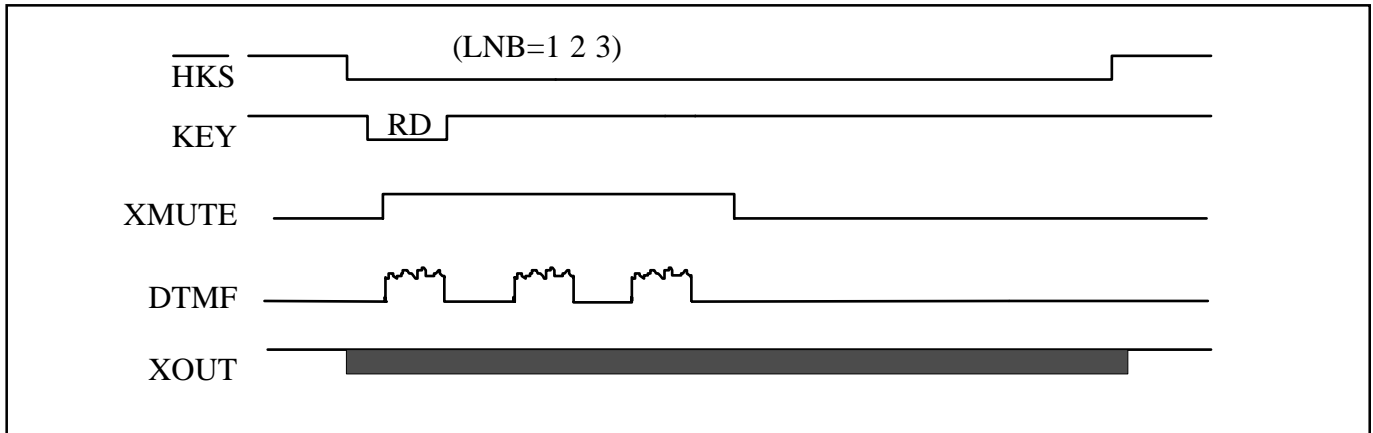

Figure 8. Redial operating Timing( Tone Mode )

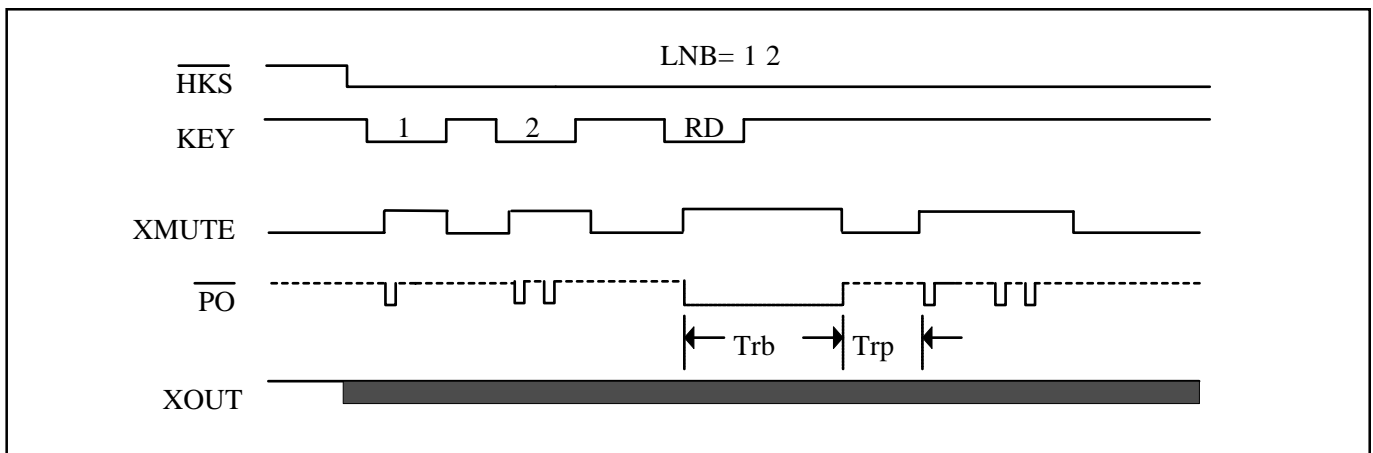

Figure 9. One key Redial operating Timing( Pulse Mode )

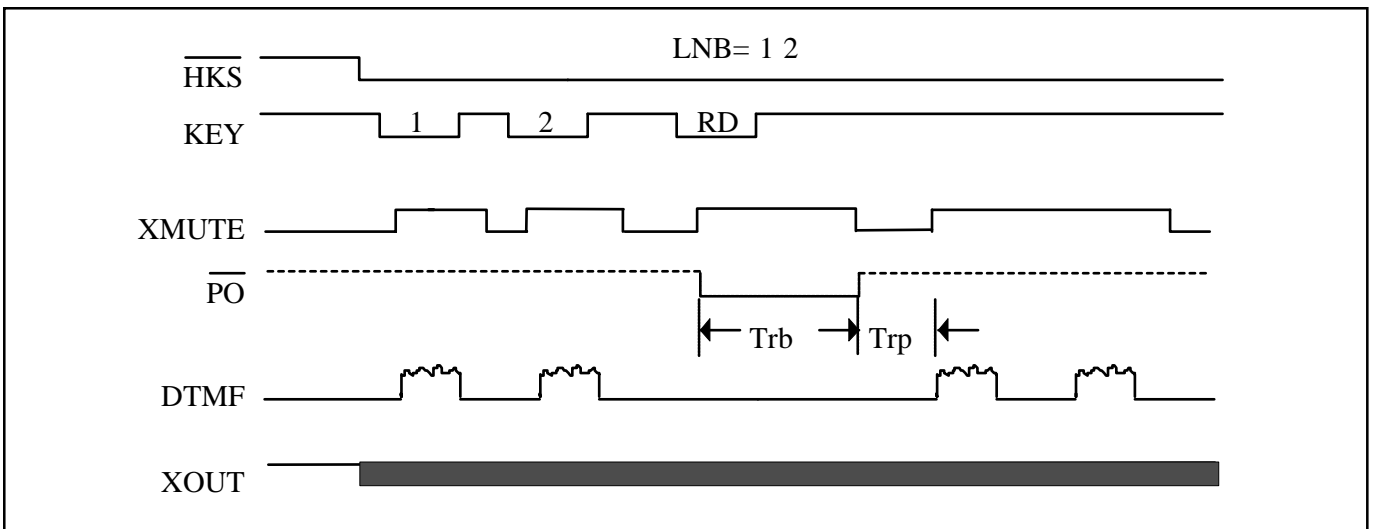

Figure 10. One key Redial operating Timing( Tone Mode )

**Preliminary**

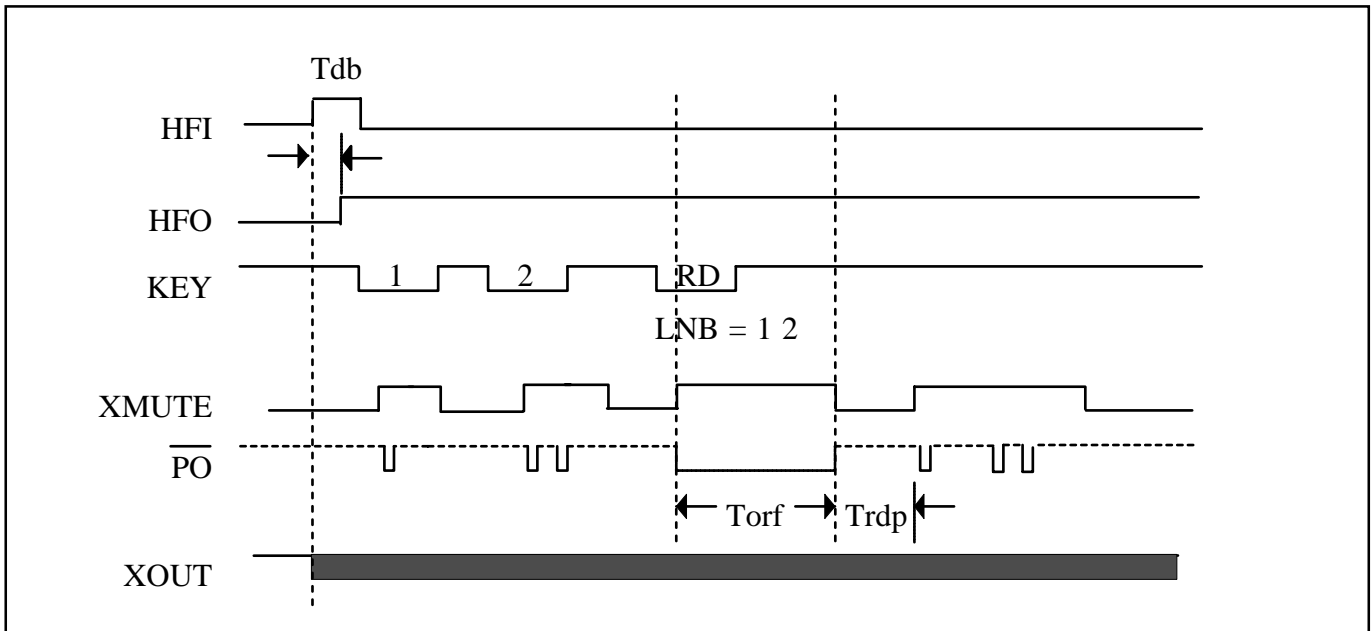

Figure 11. Handfree Mode One key Redial operating Timing ( Pulse Mode )

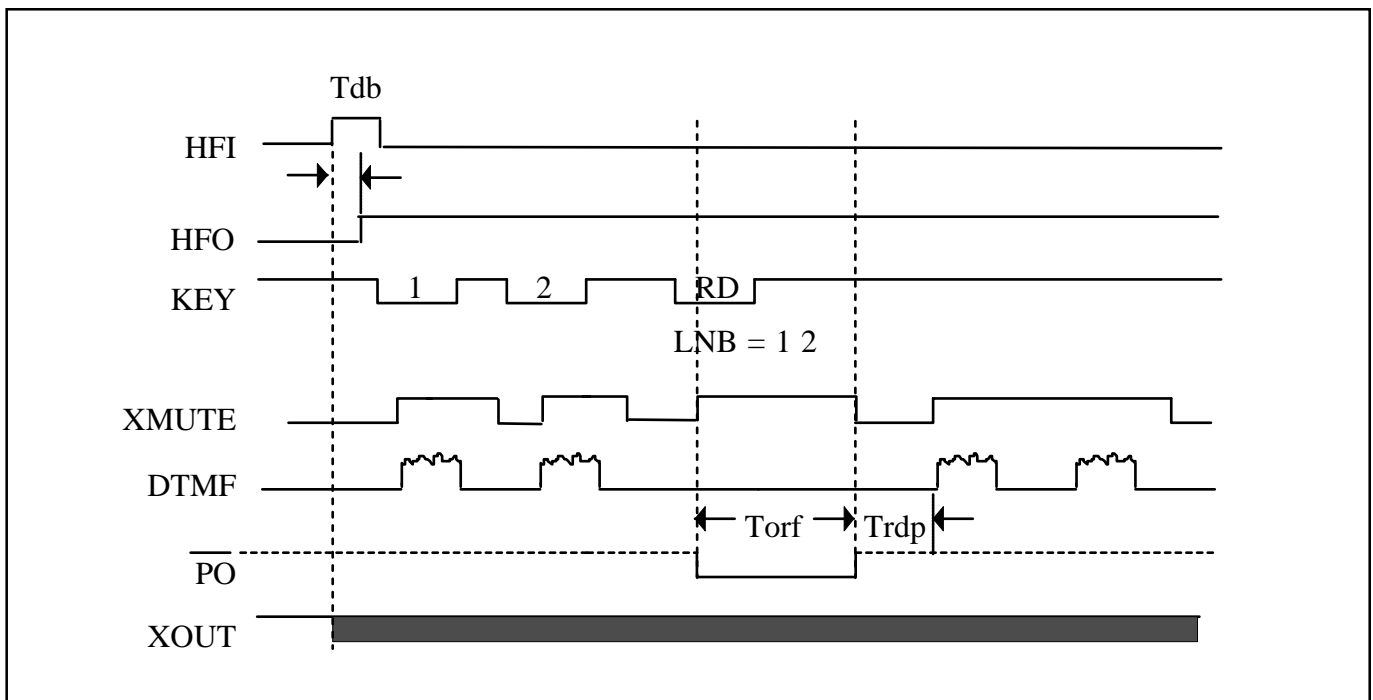

Figure 12. Handfree Mode One key Redial operating Timing ( Tone Mode )

**Preliminary**

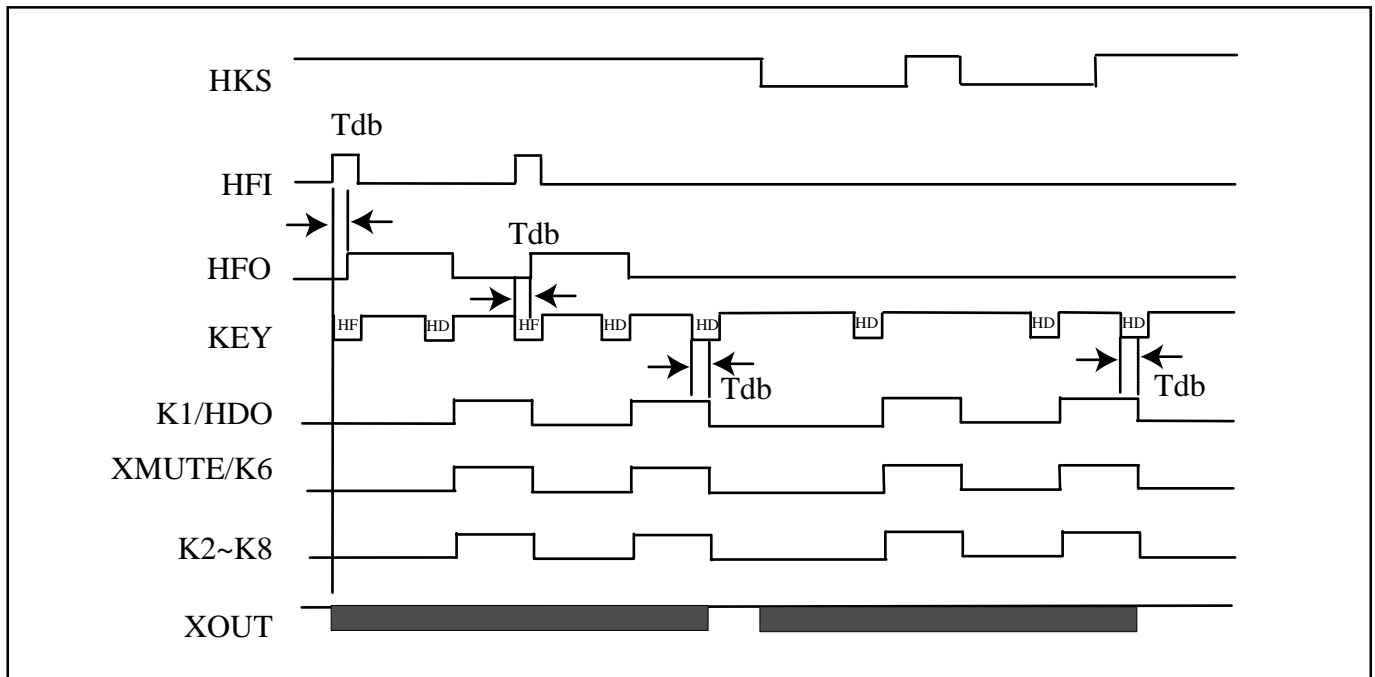

Figure 13. Handfree and Hold operating Timing

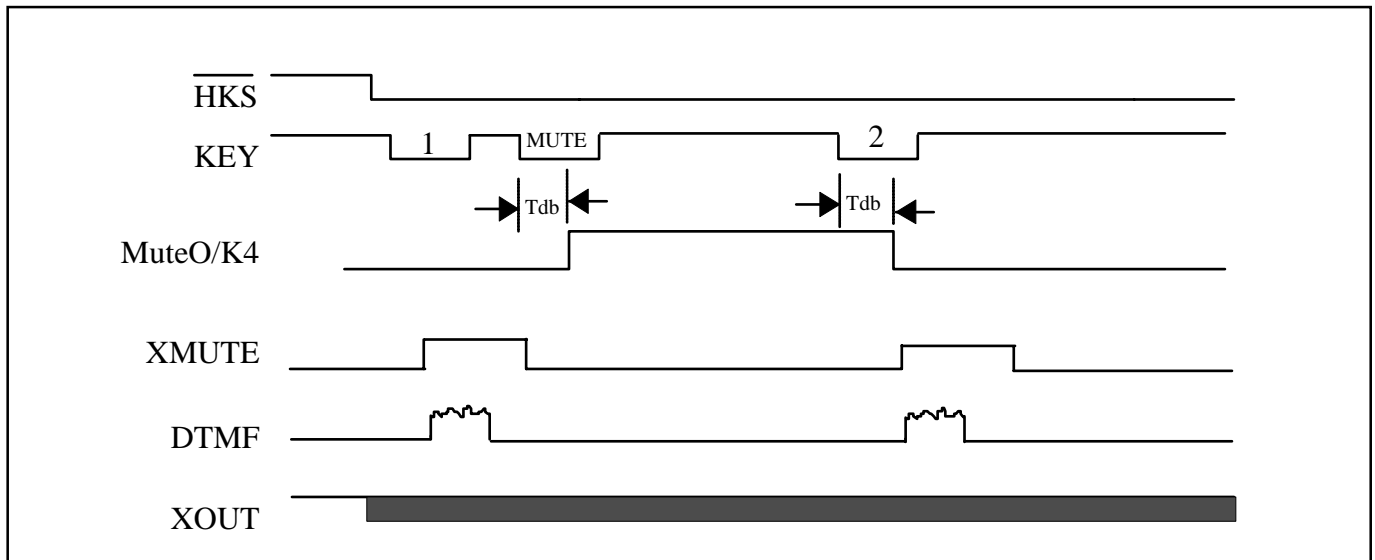

Figure 14. Mute operating Timing



**Preliminary**

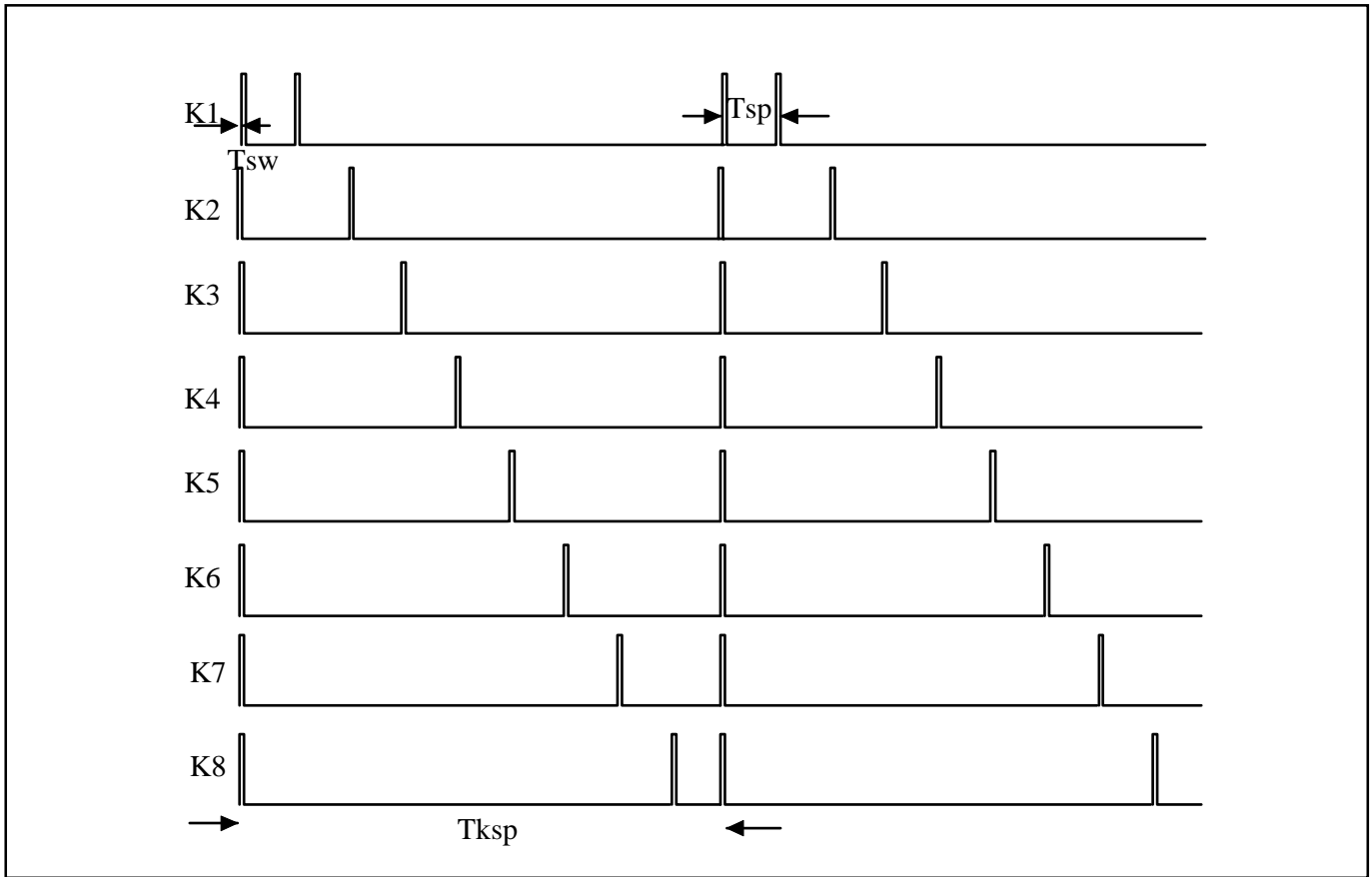

Figure 15. Key board scan Timing

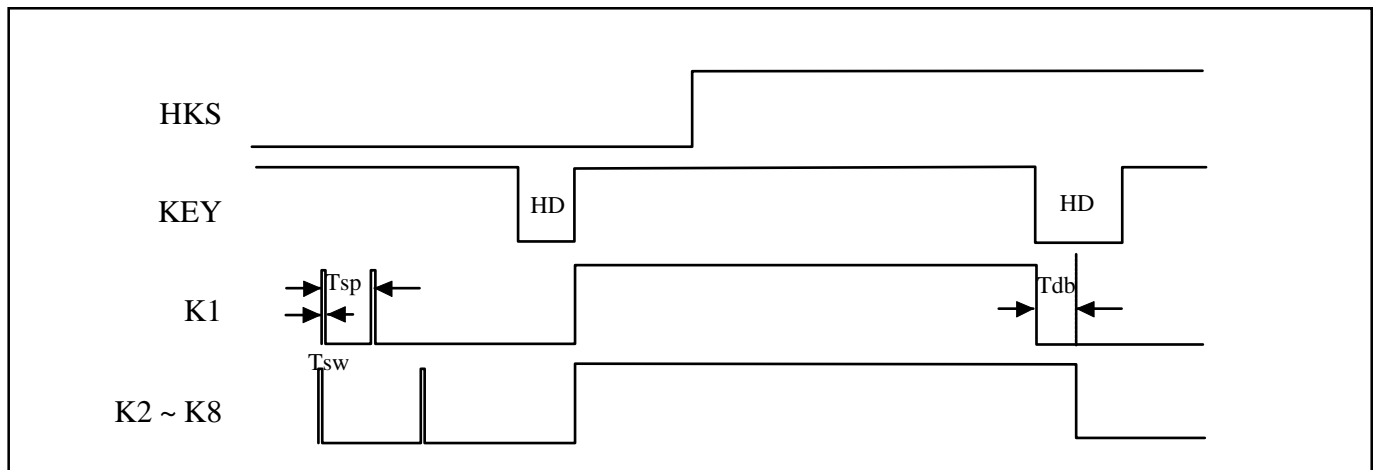

Figure 16. Hold active Keyboard scan Timing

**Preliminary**

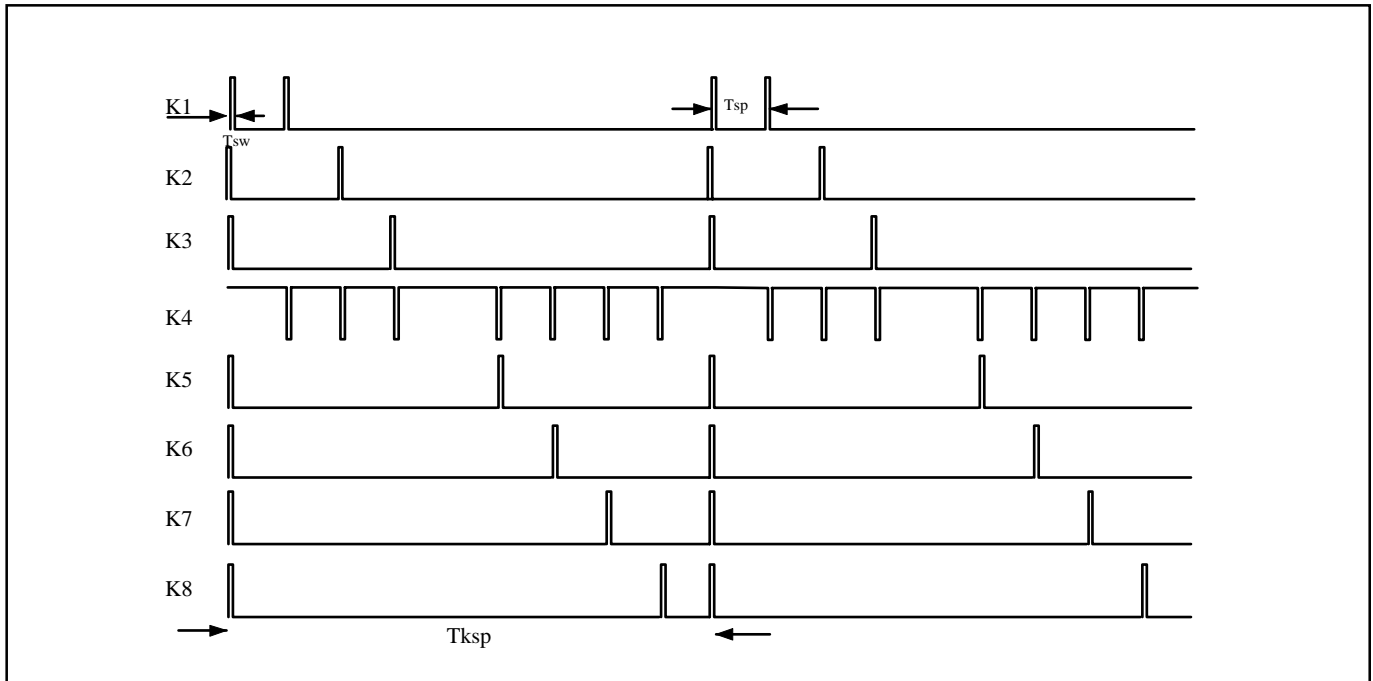

Figure 17. Mute active Keyboard scan Timing

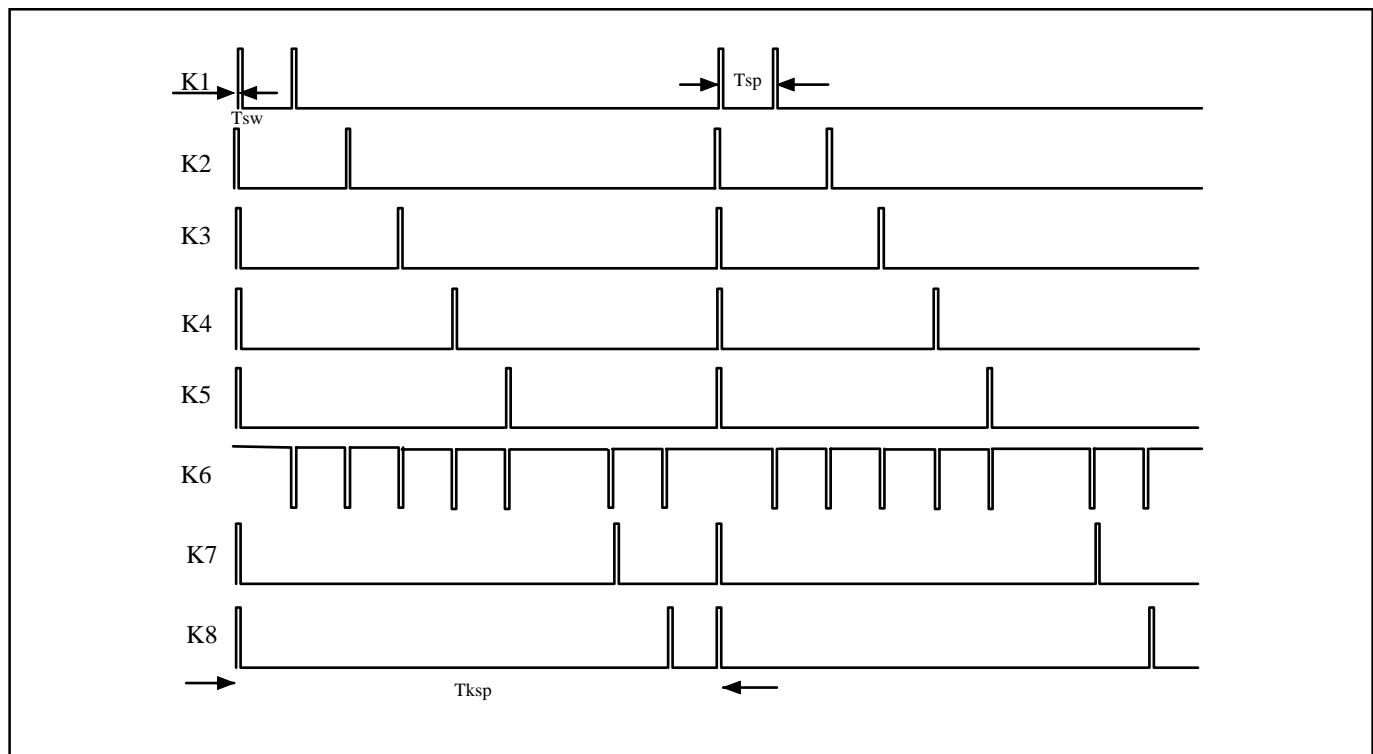
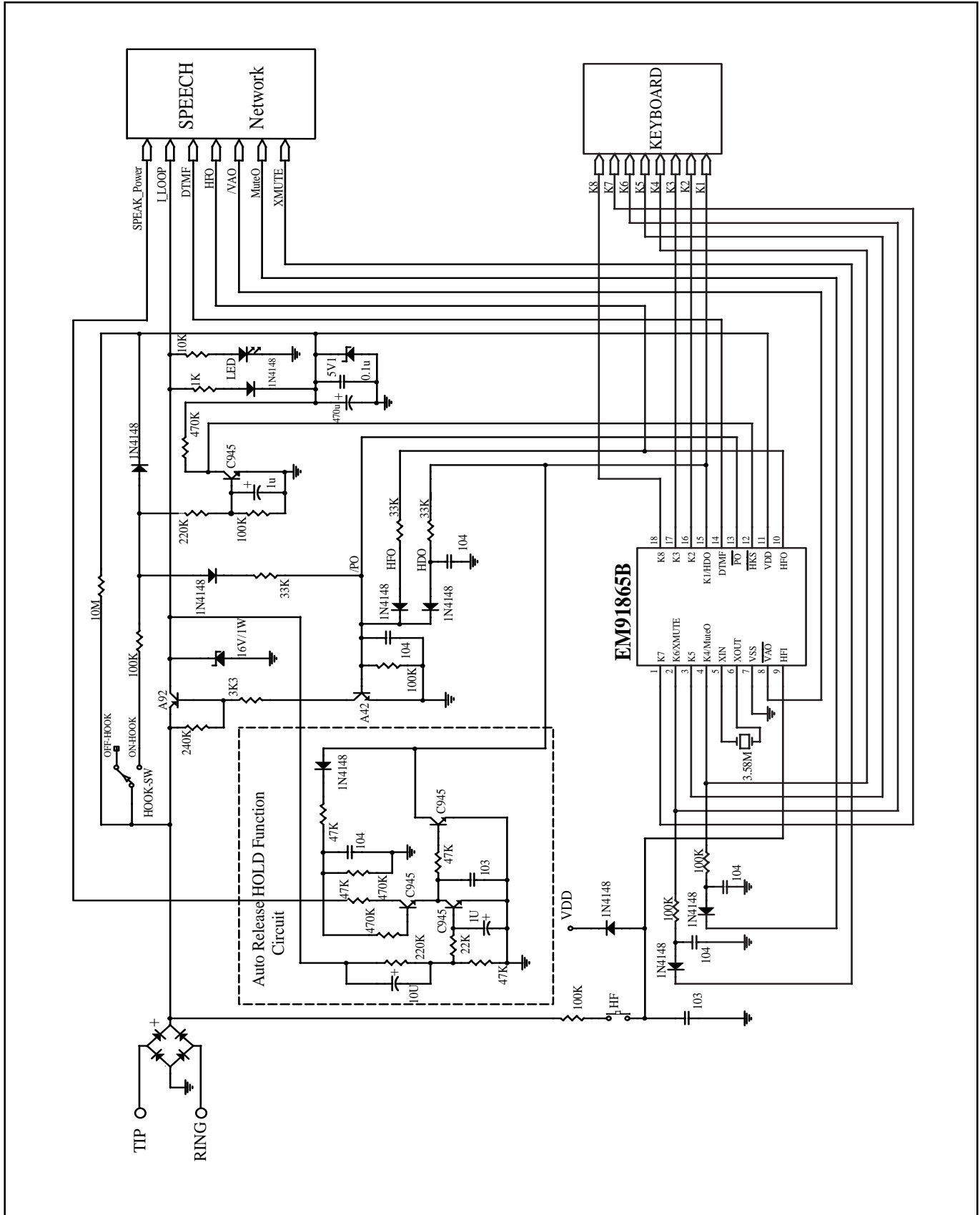

Figure 18. XMUTE active key board scan Timing

**Preliminary**

**APPLICATION CIRCUIT : CONTROL CIRCUIT**



\* This specification are subject to be changed without notice.

**Preliminary**

**APPLICATION CIRCUIT : KEYBOARD AND R\_OPTION**

