



ENH057Q1-350/450/600 Color TFT-LCD Module Features GENERAL DESCRIPTION

Panelview provides optically enhanced solutions to the standard Sharp LQ057Q3DC02 color active matrix LCD module. The first enhancement is an index matching (IM) film lamination to the front surface of the display polarizer. The IM film is available in two surface treatments - IM/Clear and IM/110 (a 10% diffusion). The second enhancement is the incorporation of a reflective polarizer (RP) to improve brightness by up to 40%. The third enhancement is the addition of prism films (RPP) further increasing the brightness of the display. The module is composed of a color TFT-LCD panel, driver ICs, control circuit, power supply circuit and a backlight unit. Graphics and text can be displayed on a 320 X 3 X 240 dot panel with 262, 144 color by supplying 18 bit data signal (6bit/color), four timing signals.

The TFT-LCD panel used for this module is a low-reflection and higher-color-saturation type. Therefore, this module is also suitable for multimedia use. Viewing angle is 12 o'clock direction. This module is the type of wide viewing angle and high brightness 350cd/m². It has horizontal display mode and vertical display mode.

Backlight-driving DC/AC inverter is not built in this module.

Panelview assumes no responsibility for any damage resulting from the use of the device which does not comply with the instructions and the precautions specified in these specification sheets. Panelview does assume the responsibility for the warranty of the enhanced product.

MECHANICAL SPECIFICATIONS

Parameter	Specifications	Units
Display size	14.4 (5.7") Diagonal	cm
Active area	115.2 (H) x 86.4 (V)	mm
Pixel format	320 (H) x 240 (V)	pixel
	(1 pixel=R+G+B dots)	-
Pixel pitch	0.360 (H) x 0.360 (V)	mm
Pixel configuration	R,G,B vertical stripe	-
Display mode	Normally white	-
Unit outline dimensions (1)	144.0 (W) x 104.6 (H) x 13.0(D)	mm
Mass	220 ± 20	g
Surface treatment	IM/Clear (glossy) or IM/110 and hardcoat 3H	-

Note:

1. Excluding backlight cables.

Note: This measurement is typical, and see Fig. 3 for details.

White Electronic Designs Corp. reserves the right to change products or specifications without notice.

Original specifications created by Sharp.



INPUT TERMINALS
TTL-LCD Panel Driving

CN1 Used connector:08-62 10-033-340-800 (Kyocera Elco Corporation)

Pin No.	Symbol	I/O	Function	Remarks
1	GND	-	GND	
2	CK	I	Clock signal for sampling each data signal	
3	H _{SYNC}	I	Horizontal synchronous signal (Negative)	
4	V _{SYNC}	I	Vertical synchronous signal (Negative)	
5	GND	-	GND	
6	R0	I	RED data signal (LSB)	
7	R1	I	RED data signal	
8	R2	I	RED data signal	
9	R3	I	RED data signal	
10	R4	I	RED data signal	
11	R5	I	RED data signal (MSB)	
12	GND	-	GND	
13	G0	I	GREEN data signal (LSB)	
14	G1	I	GREEN data signal	
15	G2	I	GREEN data signal	
16	G3	I	GREEN data signal	
17	G4	I	GREEN data signal	
18	G5	I	GREEN data signal (MSB)	
19	GND	-	GND	
20	B0	I	BLUE data signal (LSB)	
21	B1	I	BLUE data signal	
22	B2	I	BLUE data signal	
23	B3	I	BLUE data signal	
24	B4	I	BLUE data signal	
25	B5	I	BLUE data signal (MSB)	
26	GND	-	GND	
27	ENAB	I	Signal to settle the horizontal display position (Positive)	(1)
28	V _{CC}	-	+3.3V power supply	
29	V _{CC}	-	+3.3V power supply	
30	R/L	I	Horizontal display mode select signal L: Normal, H: Left/Right reverse mode	(2)
31	U/D	I	Vertical display mode select signal L: Normal, H: Up/Down reverse mode	(3)
32	V/Q	I	VGA/QVGA mode select signal	
33	GND	-	GND	

Note:

- The horizontal display start timing is settled in accordance with a rising timing of ENAB signal. In case ENAB is fixed "Low", the horizontal start timing is determined as described in "Backlight Driving: on p.5. Don't keep ENAB "Low" during operation.



R/L= L, U/D=H

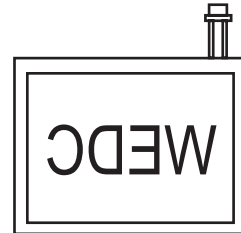

R/L= H, U/D= H



R/L= L, U/D=L



R/L= H, U/D= L

BACKLIGHT DRIVING

CN2 Used connector: BHR-2(8.0)VS-1N (JST)
Corresponding connector: SM02(8.0)B-BHS-1N-TB (JST) (installed on a board.)

Pin No.	Symbol	Function	Color of Cable
1	V _{LOW}	Power supply for lamp (Low voltage side)	White
2	NC	This is electrically opened	-
3	V _{HIGH}	Power supply for lamp (High voltage side)	Red

ABSOLUTE MAXIMUM RATINGS

Parameter	Symbol	Condition	Ratings	Unit	Remark
Input voltage	V _i	t _a =25°C	-0.3~ + 6.0	V	(1)
+3.3V supply voltage	V _{CC}	t _a =25°C	0~ + 4.0	V	-
Storage temperature	t _{STG}	-	-30~ + 80	°C	(2)
Operating temperature (Panel)	Topa1	-	-10~ + 70	°C	(2, 3, 4)
Operating temperature (Ambient)	Topa2	-	-10~ + 70	°C	(5)

Notes:

- CK, RO~R5, G0~G5, B0~B5, H_{SYNC}, V_{SYNC}, ENAB, R/L, U/D, V/Q.
- No parameter is allowed to exceed the range on the surface of the display.
- Maximum wet-bulb temperature at 39°C or less. No dew condensation.
- Only operation is guaranteed at operating temperature. Contrast, response time, another display quality are evaluated at =25°C.
- The ambient temperature, when backlight is on. (Reference)



ELECTRICAL CHARACTERISTICS

TFT-LCD PANEL DRIVING

	Parameter	Symbol	MIN	TYP	MAX	Unit	Remarks
+3.3V	Supply voltage	V_{CC}	+3.3	+3.3	+3.6	V	(1)
	Current dissipation	I_{CC}	-	130	160	mA	(2)
	Permissible input ripple voltage	V_{RF}	-	-	100	mVp-p	$V_{CC}=+3.3V$
	Input voltage (Low)	V_{IL}	0	-	$0.3V_{CC}$	V	(3)
	Input voltage (High)	V_{IH}	$0.7V_{CC}$	-	+5.5	V	
	Input current (Low)	I_{OL1}	-	-	10	μA	$V_I=0V$ (3)
Input current (High)		I_{OH1}	-	-	10	μA	$V_I=3.3-5.0V$ (4)
		I_{OH2}	-	-	100	μA	$V_I=3.3-5.0V$ (5)

Notes:

- V_{CC} -turn-on conditions
 $0 < t1 \leq 20ms$
 $0 < t2 \leq 50ms$
 $0 < t3 \leq 1s$

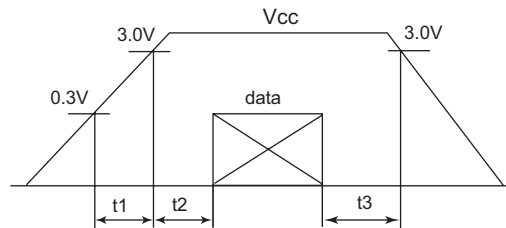

V_{CC} -dip conditions

V_{CC} -dip conditions should also follow the V_{CC} -turn-on conditions
 $t_d \leq 20ms$

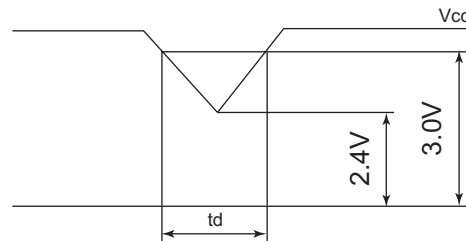



2. $V_{CC}=3.3V$ V/Q= "H"

Typical current situation
Maximum current situation

:64-gray bar pattern
:Vertical stripe pattern by GS0 and GS42 signal on every other pixel.
(This pattern is used temporarily)

Timing: Typical signal

Timing: Typical signal

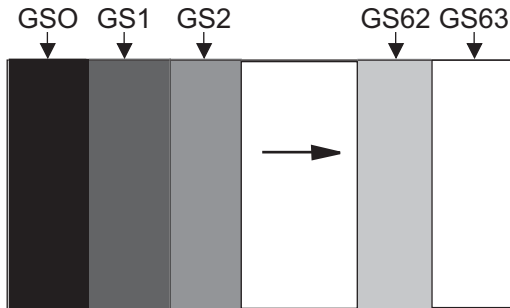

Typical Current Situation

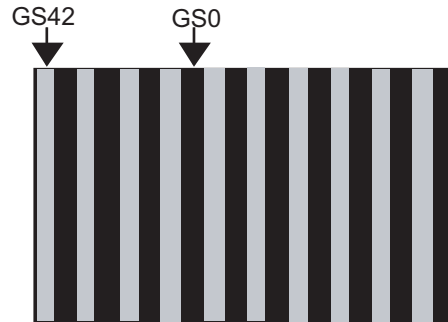

Maximum current situation

3. CK, RO-R5, GO-G5, BO-B5, HSYNC, VSYNC, ENAB, R/L, U/D, V/D
4. CK, RO-R5, GO-G5, BO-B5, HSYNC, VSYNC, R/L, U/D
5. ENAB, V/D

BACKLIGHT DRIVING SECTION

The backlight system is an edge-lighting type with single CCFT (Cold Cathode Fluorescent Tube).

The characteristics of a single lamp are shown below.

$t_A=25^{\circ}C$

Parameter	Symbol	MIN	TYP	MAX	Unit	Remark
Lamp Voltage	V_{L7}	620	690	760	Vrms	$I_L=6.5mA_{rms}$
Lamp current	I_L	4.5	5.0	5.5	mA _{rms}	normal operation
Lamp power consumption	W_L	-	3.5	-	W	-
Lamp frequency	F_L	30	-	60	KHz	(6)
Kickoff voltage	V_s	$t_A=25^{\circ}C$	-	1350	Vrms	Sealed is connected to GND
		$t_A=30^{\circ}C$	-	1470	Vrms	

(Inverter: HIU-288 [Output Condenser 22pF] Harison Electric Co., LTD.)

6. Lamp frequency may produce interference with horizontal synchronous frequency, and this may cause horizontal beat on the display. Therefore, lamp frequency shall be detached as much as possible from the horizontal synchronous frequency and from the harmonics of horizontal synchronous to avoid interference. In case of such usage under lower temperature environments, periodic lamp exchange by Panelview is recommended.



TIMING CHARACTERISTICS OF INPUT SIGNALS

Timing diagrams of input signal are shown below.

TIMING CHARACTERISTICS

Parameter Clock		Symbol	Min.	Typ.	Max.	Unit	Reward
Clock	Frequency	1/Tc	-	25.18	28.33	MHz	V/Q=H
			-	6.3	7.0	MHz	V/Q=L
	Duty ratio	TH/T	40	50	60	%	
Data	Set up time	Tds	5	-	-	ns	
	Hold time	Tdh	10	-	-	ns	
Horizontal sync. signal	Cycle	TH	30.0	31.8	-	µs	V/Q=H
			770	800	900	clock	
	TH	50.0	63.6		µs	V/Q=L	
		360	400	450	clock		
Pulse width	THp	2	96	200	clock		
Vertical sync. signal	Cycle	TV	515	525	560	line	V/Q=H
			251	262	280	line	V/Q=L
	Pulse width	TVp	2	-	34	line	
Horizontal display period		THd	320	320	320	clock	
H _{SYNC} -Clock phase difference		THc	10	-	Tc-10	ns	
H _{SYNC} -V _{SYNC} phase difference		TVh	0	-	TH-THp	ns	
Vertical sync. signal start position	TVs		34	34	34	line	V/Q=H
			7	7	7	line	V/Q=L

Notes:

- In case of lower frequency, deterioration of the display quality, flicker, etc. may occur.

HORIZONTAL DISPLAY POSITION

The horizontal display position is determined by ENAB signal.

Parameter	Symbol	MIN	TYP	MAX	Unit	Remark	
Enable signal	Set-up time	Tes	5	-	Tc-10	ns	-
	Pulse width	Tep	2	320	TH-10	clock	-
H _{SYNC} -enable signal phase difference	THe		44	-	TH-664	clock	V/Q=H
			2	-	TH-340		V/Q=L

Notes:

- When ENAB is fixed at "V/Q=Low", the display starts from the data of C52 (clock) as shown in Fig. 8.
- When ENAB is fixed at "V/Q=High", the display starts from the data of C104 (clock) as shown in Fig 8.

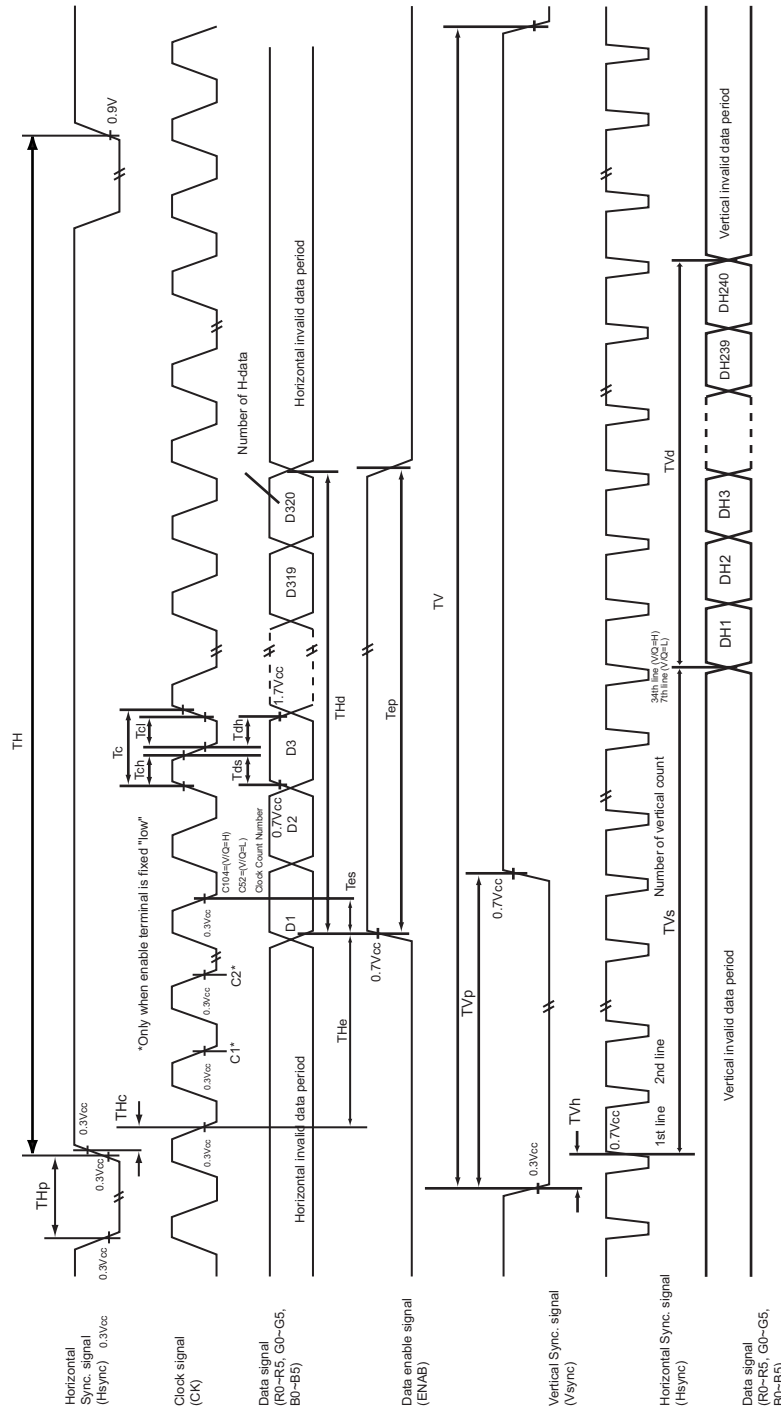

Fig 8. Input signal waveforms



INPUT SIGNALS, BASIC DISPLAY COLORS AND GRAY SCALE OF EACH COLOR

	Colors & Grayscale	Data signal																		
		Gray Scale	R0	R1	R2	R3	R4	R5	G0	G1	G2	G3	G4	G5	B0	B1	B2	B3	B4	B5
Basic Color	Black	-	0	0	0	0	0	0	0	0	0	0	0	0	0	0	0	0	0	0
	Blue	-	0	0	0	0	0	0	0	0	0	0	0	0	1	1	1	1	1	1
	Green	-	0	0	0	0	0	0	1	1	1	1	1	1	0	0	0	0	0	0
	Cyan	-	0	0	0	0	0	0	1	1	1	1	1	1	1	1	1	1	1	1
	Red	-	1	1	1	1	1	1	0	0	0	0	0	0	0	0	0	0	0	0
	Magenta	-	1	1	1	1	1	1	0	0	0	0	0	0	1	1	1	1	1	1
	Yellow	-	1	1	1	1	1	1	1	1	1	1	1	1	0	0	0	0	0	0
	White	-	1	1	1	1	1	1	1	1	1	1	1	1	1	1	1	1	1	1
Gray Scale of Red	Black	GS0	0	0	0	0	0	0	0	0	0	0	0	0	0	0	0	0	0	0
	↑	GS1	1	0	0	0	0	0	0	0	0	0	0	0	0	0	0	0	0	0
	Darker	GS2	0	1	0	0	0	0	0	0	0	0	0	0	0	0	0	0	0	0
	↑	↓				↓					↓						↓			
	↓	↓				↓					↓						↓			
	Brighter	GS61	1	0	1	1	1	1	0	0	0	0	0	0	0	0	0	0	0	0
	↓	GS62	0	1	1	1	1	1	0	0	0	0	0	0	0	0	0	0	0	0
Red	GS63	1	1	1	1	1	1	0	0	0	0	0	0	0	0	0	0	0	0	
Gray Scale of Green	Black	GS0	0	0	0	0	0	0	0	0	0	0	0	0	0	0	0	0	0	0
	↑	GS1	0	0	0	0	0	0	1	0	0	0	0	0	0	0	0	0	0	0
	Darker	GS2	0	0	0	0	0	0	0	1	0	0	0	0	0	0	0	0	0	0
	↑	↓				↓														
	↓	↓				↓														
	Brighter	GS61	0	0	0	0	0	0	1	0	1	1	1	1	0	0	0	0	0	0
	↓	GS62	0	0	0	0	0	0	0	1	1	1	1	1	0	0	0	0	0	0
Green	GS63	0	0	0	0	0	0	1	1	1	1	1	1	0	0	0	0	0	0	
Gray Scale of Blue	Black	GS0	0	0	0	0	0	0	0	0	0	0	0	0	0	0	0	0	0	0
	↑	GS1	0	0	0	0	0	0	0	0	0	0	0	0	1	0	0	0	0	0
	Darker	GS2	0	0	0	0	0	0	0	0	0	0	0	0	0	1	0	0	0	0
	↑	↓																		
	↓	↓																		
	Brighter	GS61	0	0	0	0	0	0	0	0	0	0	0	0	1	0	1	1	1	1
	↓	GS62	0	0	0	0	0	0	0	0	0	0	0	0	0	1	1	1	1	1
Blue	GS63	0	0	0	0	0	0	0	0	0	0	0	0	1	1	1	1	1	1	

Notes:

- 0: Low level voltage 1: High level voltage.
- Each basic color can be displayed in 64 gray scales from 6 bit data signals.
- With the combination of total 18 bit data signals, the 262, 144-color display can be achieved on the screen.



OPTICAL CHARACTERISTICS

$t_A=25^{\circ}\text{C}$, $V_{CC}=+3.3\text{V}$

Parameter		Symbol	Condition	Min	Typ	Max	Unit	Remarks
Viewing Angle Range	Horizontal	$\theta 21, \theta 22$	$(CR \geq 5)$	60	65	-	Deg.	(1)
	Vertical	$\theta 11$		60	65	-	Deg.	
		$\theta 12$		35	40	-	Deg.	
Contrast Ratio		CRmax	Best Viewing Angle	60	-	-	-	(2)
Response Time	Rise	τr	$\theta = 0^{\circ}$	-	30	60	ms	(3)
	Decay	τd		-	50	100	ms	
Luminance of White		Y	$I_L=5.0\text{mArms}$	260	350	-	cd/m^2	(4)
Chromaticity of White		x		0.263	0.313	0.363	-	
		y		0.279	0.329	0.379	-	
Lamp Endurance	$+25^{\circ}\text{C}$	-	Continuation Operation	40,000	-	-	hour	(5)

Notes:

1. The inverter was used to evaluate the backlight unit.
2. The measurements were done 30 mins later after switching on the backlight.

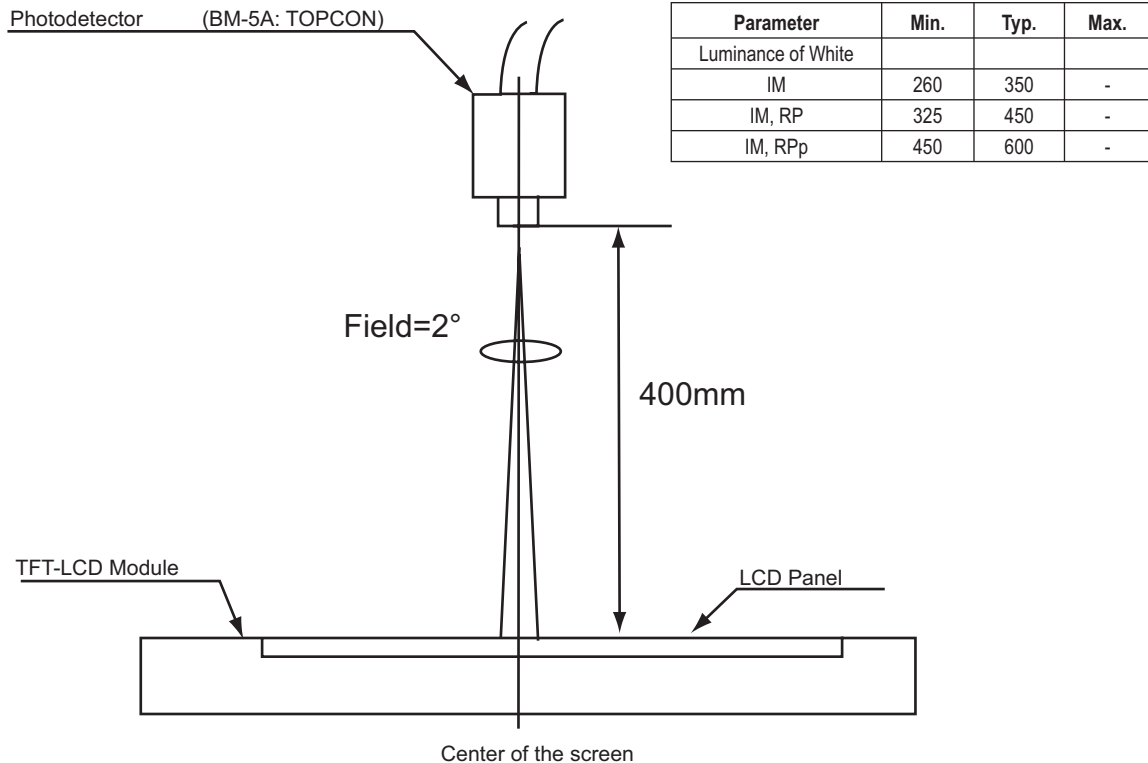

Optical Characteristics Measurement Method



Notes:

1. Definition of viewing angle range:

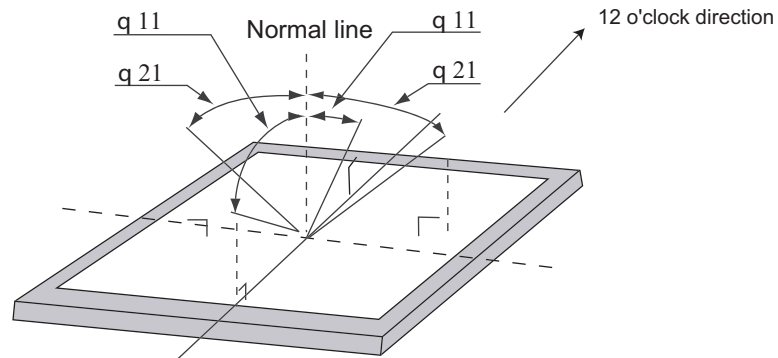

2. Definition of contrast ratio
The contrast ratio is defined as follows:

$$\text{Contrast Ratio (CR)} = \frac{\text{Luminance (brightness) with all pixels white}}{\text{Luminance (brightness) with all pixels black}}$$

3. Definition of response time
The response time is defined as the following figure and shall be measured by switching the input signal for "black" and "white".

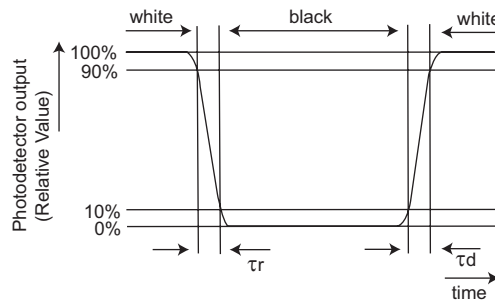

4. This shall be measured at the center of the screen. The measurement was done 30 mins later after switching on the backlight. (characteristic of the first stage)
Inverter drive frequency: 49 kHz
5. Continuous operation time which doesn't deteriorate the brightness under 50% of the brightness at the beginning.
(Condition) IL=5.0 mArms (adjusting the brightness by current)



HANDLING PRECAUTIONS

Installing the TFT-LCD module

1. TFT-LCD module has holes at the corner of the reverse side of the module to install. M2.6 tapping screw is recommended. (torque: 0.25 ~ 0.30 N x m) Be sure to design the cabinet so that the module can be installed without any extra stress such as warp or twist. Also, make certain to design the cabinet so that the switch does not apply pressure on the module.
2. Be sure to turn off the power supply when inserting or disconnecting the cable.
3. Connect GND of Inverter to the metal sealed case of the module. If the connection is not sufficient, it may cause the following:
 - a) Increasing of noise from backlight.
 - b) Unstable inverter output.
 - c) Partial heating up.

INSTALLATION OF THE TFT-LCD MODULE

Installation Precautions

1. Since the front polarizer is easily damaged, avoid rubbing against anything hard or sharp. Use ionized nitrogen to blow off the particles. If polarizer is soiled, wipe lenses with soft cloth.
2. Wipe off water drop immediately. Long contact with water may cause discoloration or spots.
3. Since TFT -LCD modules consist of glass and refined wires and components, it may break or crack if dropped or bumped on hard surface. Handle with care.
4. Since CMOS LSI is used in this module, use caution with static electricity and make certain one is grounded when handling.
5. Do not use LCD module in the vicinity of corrosive gases such as sulfide or chlorine gases. Polarizer may be deteriorate or cause chemical reaction that can lead 10 short circuits at the terminal points. Do not use material containing sulfide or chlorine articles in the vicinity of LCD module. At high temperature, these compounds produce corrosive gases.

NOTICE FOR THE DESIGN OF PRODUCTS

1. Design the product to keep TFT-LCD module from sodium chloride or water.
2. When designing, consider sufficient EMI countermeasures from LCD module to application.

OTHERS

1. Ultraviolet rays deteriorate Liquid-crystal. Do not leave it in direct sun light or in strong ultraviolet rays.
2. If liquid-crystal is kept below the rated storage temperature the isotropic liquid becomes coagulated and may become permanently damaged. Therefore, it is recommended to keep it at room temperature as much as possible.
3. Kick-off voltage of backlight may be required over rated voltage, due to the leakage current from the lamp cable.
4. If the LCD breaks, liquid-crystal may leak from the panel. Be careful so that it does not enter one's eyes and mouth.



PACKING FORM

1. Piling number of cartons :MAX. 12 pcs.
2. Package quantity in one carton :MAX. 20 pcs.
3. Carton size :442 (W) X 390 (D) X 170 (H)mm
4. Conditions for storage
 - Temperature :0-40°C
 - Humidity :60%RH or less
 - Atmosphere :Display should not be exposed to harmful gases.
 - Period :3 months
 - Opening of the package :In order to prevent the LCD module from breakdown by electrostatic charges, control room humidity over 50%RH and one must be grounded when opening the package.

OTHERS

3. Image retention may occur when a fixed pattern is displayed for a long period of time.
4. TFT-LCD drive input and output connector (33 pins Kyocera elco corporation :08.6210-033-340-800)
 - a) Adapted FPC
 - b) Holding power of the terminal : 0.9 N/pin or over (pulling out each terminal at 25±3 mm/min)
 - c) Durability against inserting and extracting : Double of the beginning data or less
(Difference of the contact resistance after 20 times of inserting and extracting, using adapted FPC.)

Rear View

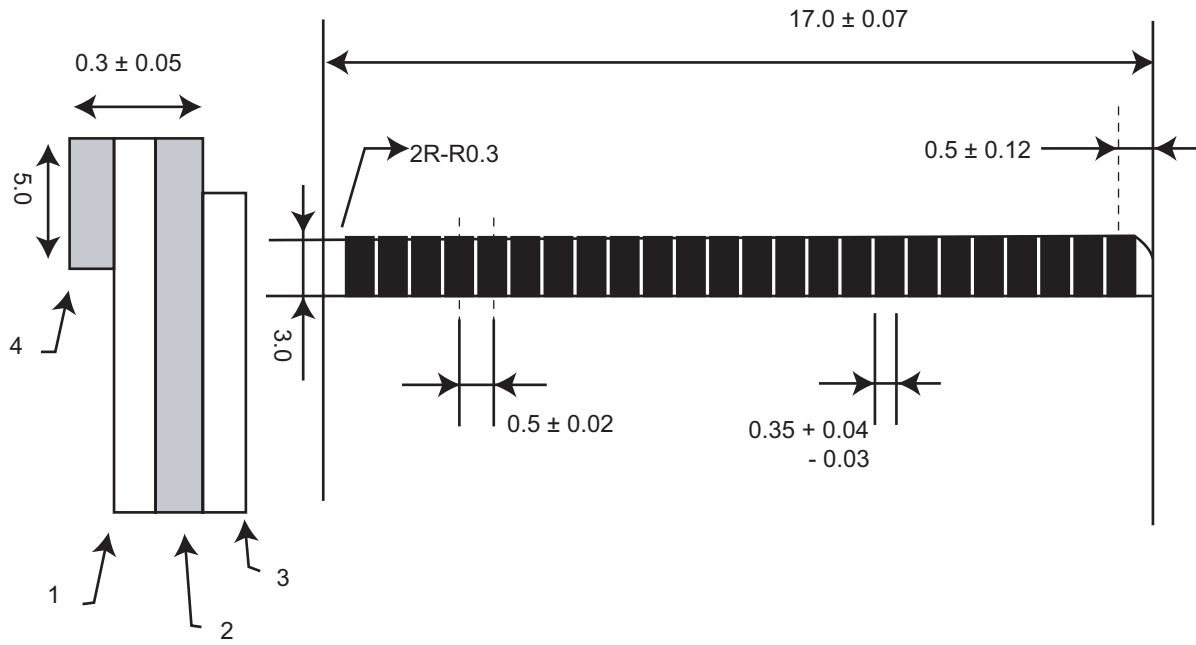

Number	Name	Material
1	Base	Polyimide or the same kind of material (25µm thickness)
2	Copper layer	Thin copper film (35 µm thickness) Solder plating 20µm or more
3	Cover Layer	Polyimide or same kind of material
4	Support board	Polyester, Polyimide or the same kind of material (188 µm thickness)

Note:

1. FPC adapted to Input/Output connector (0.5 mm pitch)



CONDITIONS OF RELIABILITY TEST

No.	Test items	Conditions	
1	High temperature storage test	t _s =80°C	240h
2	Low temperature storage test	t _s =-30°C	240h
3	High temperature and high humidity operating test	t _p =40°C, 95%RH (No condensation)	240h
4	High temperature operating test	t _s =70°C	240h
5	Low temperature operating test	t _s =-10°C	240h Lamp endurance is excepted
6	Electrostatic discharge test	±200V, 200pF(OΩ) 1 time for each terminal	
7	Shock test (non-operating)	Max gravity Direction	:490m/s ² • 6ms :±X, ±Y, ±Z 3 minutes for each direction (JIS C0041)
8	Vibration test (non-operating)	Frequency Sweep: 33.3Hz~400Hz Test period	:5~57Hz/Vibration width : 0.15mm :58~500Hz/Acceleration:9.8m/s ² :11 minutes :3 hours (1 hour in each direction of X, Y, Z)
9	Heat shock test	t _s =-30°C~+80°C/100 cycles (0.5h) (0.5h)	

Note:

- The following figure shows the definition of X axis, Y axis, and Z axis.

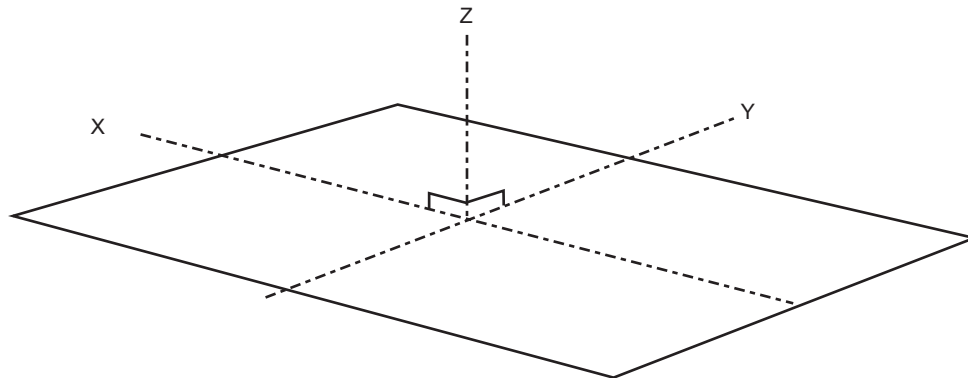



OUTLINE DIMENSIONS OF 5.7 TFT MODEL

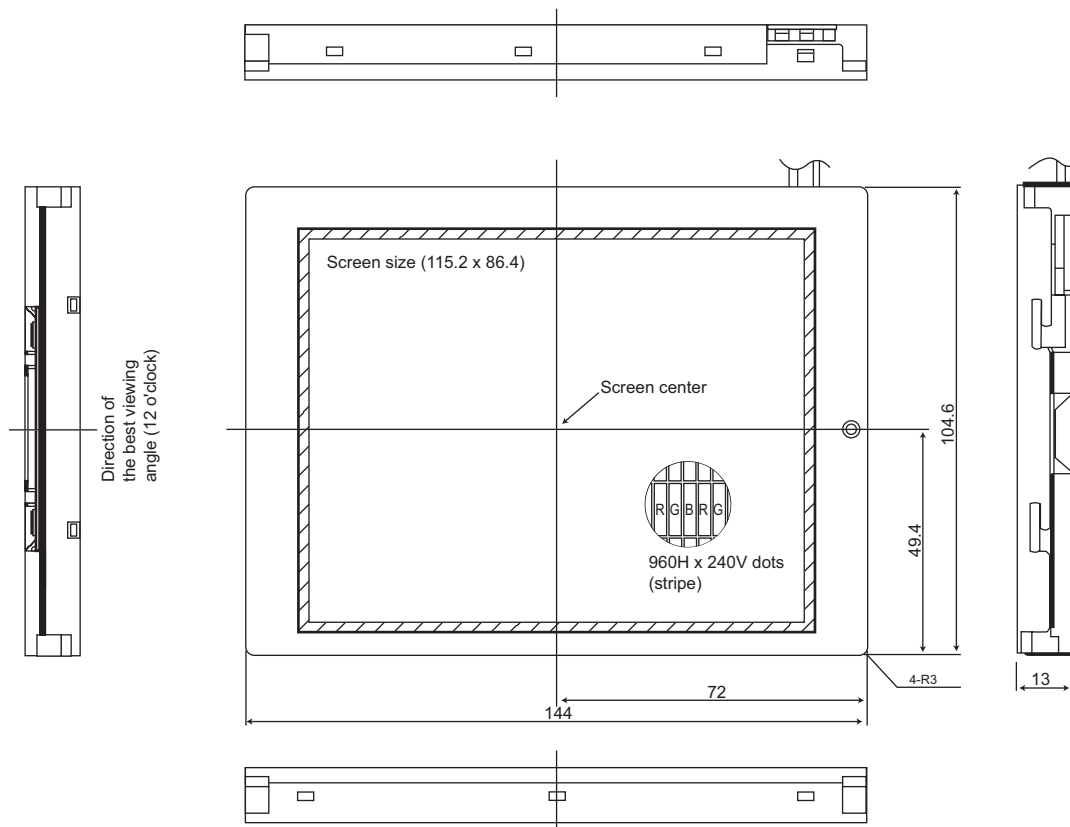

Notes:

1. The tolerance is ± 0.5 except when specified.
2. The tolerance width of the module excludes warping of the case.
3. CN1 connector: ELCO 08-6210-033-340-800
4. 8L connector: JST BHR-02VS-N
5. Unit: mm

REAR VIEW

