



- Noise Suppression Choke
- 2.80 A Max. Rated Current
- 500 Vrms Isolation

Electrical Parameters @ 25° C

Inductance (mH ± 25%)	DCR (mΩ Max.)	Turns Ratio	SRF (MHz Typ.)
@10 KHz, 0.1 Vrms	Matched with ± 5%		
1.47	80	1 : 1	2.0
Pins 1-2, 3-4	Pins 1-2, 3-4	Pins 1-2 : 3-4	

Schematic

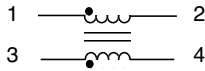

Impedance Curve

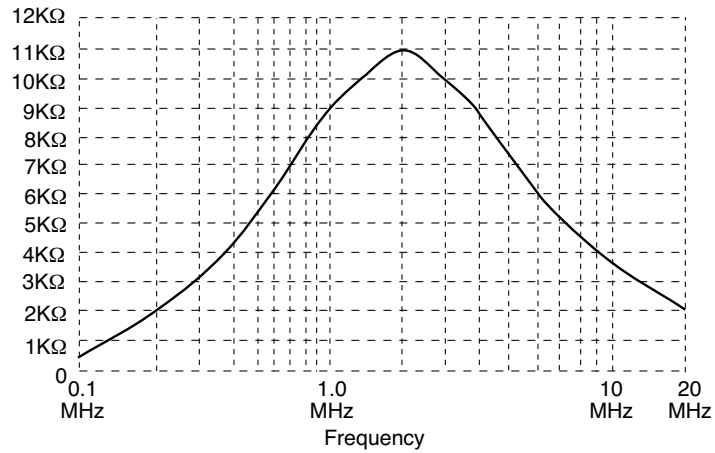

Package

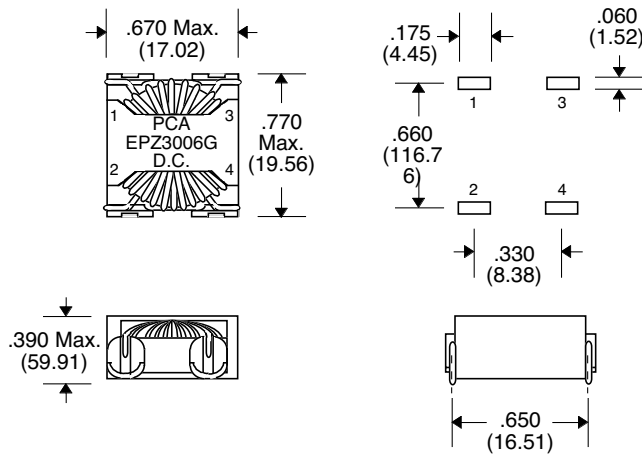

Unless Otherwise Specified Dimensions are in Inches /mm ± .010 / .25