



# Microprocessor Reset IC

## Features

- High  $\pm 2\%$  Voltage Threshold Accuracy
- Independently Adjustable High- and Low-Voltage Thresholds
- Fully Specified Over Temperature
- Available in Three Output Configurations
  - Push-Pull  $\overline{\text{RESET}}$  Output (G680L)
  - Push-Pull  $\overline{\text{RESET}}$  Output (G680H)
  - Open-Drain  $\overline{\text{RESET}}$  Output (G681L)
- 140ms min Power-On Reset Pulse Width
- 4 $\mu\text{A}$  Supply Current
- Power Supply Transient Immunity
- 5-Pin SOT23-5 Packages

## Applications

- Computers
- Controllers
- Intelligent Instruments
- Critical  $\mu\text{P}$  and  $\mu\text{C}$  Power Monitoring
- Portable / Battery-Powered Equipment
- Automotive

## General Description

The G680/G681 are microprocessor ( $\mu\text{P}$ ) supervisory circuits used to monitor the power supplies in  $\mu\text{P}$  and digital systems. High- and Low- voltage thresholds can be adjusted independently, allowing for wide hysteresis. Voltage detection thresholds are accurate to 2%.

These circuits perform a single function: they assert a reset signal whenever the  $V_{\text{CC}}$  supply voltage declines below the low-voltage threshold, keeping it asserted for at least 140ms after  $V_{\text{CC}}$  has risen above the high-voltage threshold.

The G681L has an open-drain output stage, while the G680 have push-pull outputs. The G681L's open-drain  $\overline{\text{RESET}}$  output requires a pull-up resistor that can be connected to a voltage higher than  $V_{\text{CC}}$ . The G680L have an active-low  $\overline{\text{RESET}}$  output, while the G680H has an active-high  $\overline{\text{RESET}}$  output. The reset comparator is designed to ignore fast transients on threshold input.

The IC's power supply is separate from the detector inputs, allowing the G680/G681 to be powered from a down-stream supply. Low supply current (4 $\mu\text{A}$ , typical) makes the G680/G681 ideal for use in portable equipment. The G680/G681 are available in 5 pin SOT 23-5 packages.

## Ordering Information

PART	TEMP. RANGE	PIN-PACKAGE
G680H(L)T1	-40°C ~ +105°C	SOT23-5
G681LT1	-40°C ~ +105°C	SOT23-5

## Pin Configuration

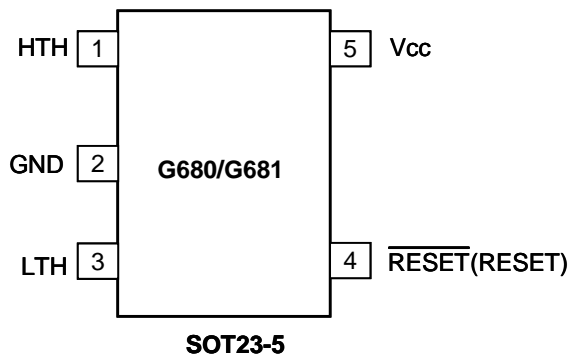

## Typical Operating Circuit

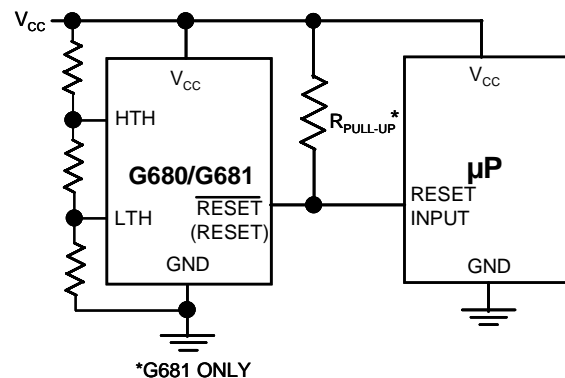

**Absolute Maximum Ratings**

Terminal Voltage (with respect to GND)		Continuous Power Dissipation ( $T_A = +70^\circ\text{C}$ )
$V_{CC}$ .....	-0.3V to +6.0V	SOT23-5.....
Input Voltage ( $V_{LTH}$ , $V_{HTH}$ ).....	-0.3V to ( $V_{CC} + 0.3V$ )	Operating Temperature Range .....
RESET, $\overline{\text{RESET}}$ (push-pull).....	-0.3V to ( $V_{CC} + 0.3V$ )	Storage Temperature Range.....
$\overline{\text{RESET}}$ (open drain).....	-0.3V to +6.0V	Lead Temperature (soldering, 10s) .....
Input Current, $V_{CC}$ .....	20mA	
Output Current, RESET, $\overline{\text{RESET}}$ .....	20mA	

Stresses beyond those listed under "Absolute Maximum Ratings" may cause permanent damage to the device. These are stress ratings only, and functional operation of the device at these or any other conditions beyond those indicated in the operational sections of the specifications is not implied. Exposure to absolute maximum rating conditions for extended periods may affect device reliability.

**Electrical Characteristics**

( $V_{CC}$  = full range,  $T_A = -40^\circ\text{C}$  to  $+105^\circ\text{C}$ , unless otherwise noted. Typical values are at  $T_A = +25^\circ\text{C}$ ,  $V_{CC} = 3.3V$  (Note 1))

PARAMETER	SYMBOL	CONDITION	MIN	TYP	MAX	UNITS
$V_{CC}$ Range			2.5		5.5	V
Supply Current (SOT23)	$I_{CC}$	$V_{CC} < 5.5V$		4	7.5	$\mu\text{A}$
Reset Threshold	$V_{TH}$		1.225	1.25	1.272	V
Reset Threshold Tempco				70		ppm/ $^\circ\text{C}$
$V_{LTH}$ to Reset Delay (Note 2)		$V_{LTH} = V_{TH}$ to $V_{TH} - 100\text{mV}$		15		$\mu\text{s}$
Reset Active Timeout Period			120	420	860	ms
$\overline{\text{RESET}}$ (RESET) Output Current Low	$I_{OL}$	$V_{CC} = 2.5V$ , $V_{\overline{\text{RESET}}} (V_{\text{RESET}}) = 0.5V$ , $\overline{\text{RESET}}$ Asserted or RESET not asserted	8			mA
$\overline{\text{RESET}}$ Output Current High (push-pull G680)	$I_{OH}$	$V_{CC} = 2.5V$ , $V_{\overline{\text{RESET}}} (V_{\text{RESET}}) = 2V$ , $\overline{\text{RESET}}$ not asserted or RESET asserted.	2			mA
$\overline{\text{RESET}}$ Open-Drain Output Leakage Current (G681L)		$V_{HTH} > V_{TH}$ , $\overline{\text{RESET}}$ deasserted			1	$\mu\text{A}$

Note 1: Production testing done at  $T_A = +25^\circ\text{C}$ ; limits over temperature guaranteed by design.

Note 2:  $\overline{\text{RESET}}$  output is for G680L/G681L; While RESET output is for G680H.

**Selector Guide**

PART / SUFFIX	OUTPUT TYPE	TOP MARK
G680LT1	Push-pull $\overline{\text{RESET}}$	680A
G680HT1	Push-pull RESET	680B
G681LT1	Open-Drain $\overline{\text{RESET}}$	681A

**Timing Diagram**

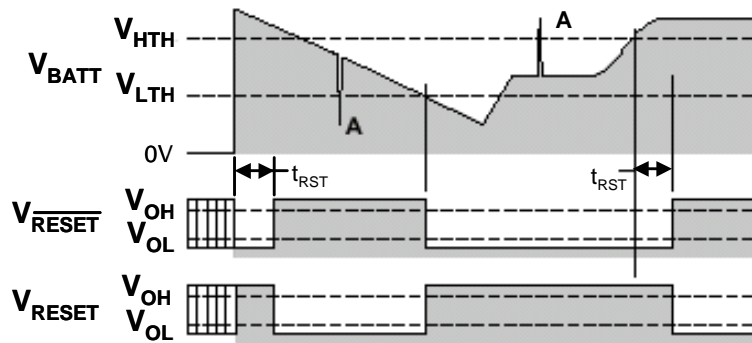

Propagation delays not shown for clarity.

**Functional Diagram**

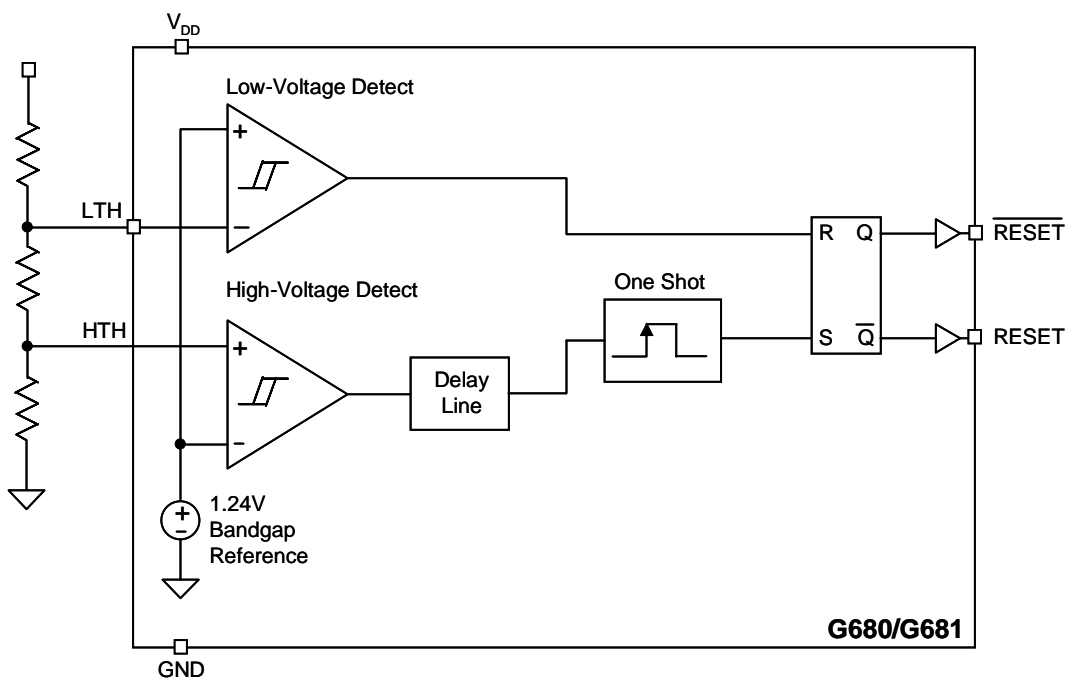

**Typical Operating Characteristics**

( $V_{CC}$  = full range,  $T_A$  =  $-40^{\circ}\text{C}$  to  $+105^{\circ}\text{C}$ , unless otherwise noted. Typical values are at  $T_A$  =  $+25^{\circ}\text{C}$ ,  $V_{CC}$  = 5V for 463/438/400 versions,  $V_{CC}$ = 3.3V for 308/293 versions, and  $V_{CC}$  = 3V for 263 version.)

**Supply Current vs. Temperature**

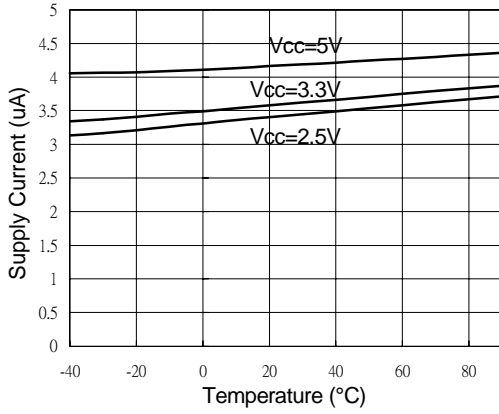

**Power -Down Reset Delay vs. Temperature**

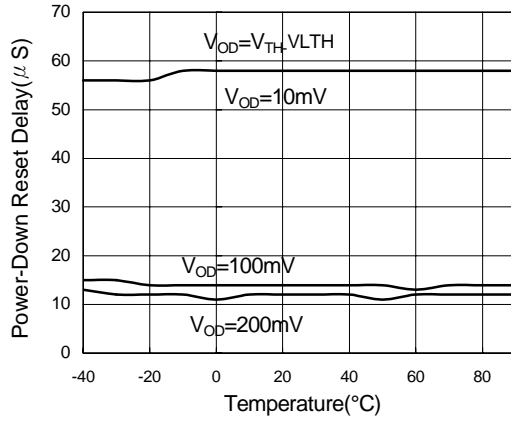

**Reset Timeout Period vs. Temperature**

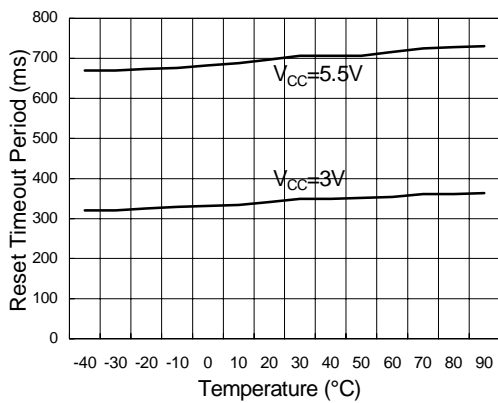

**Normalized Reset Threshold vs. Temperature**

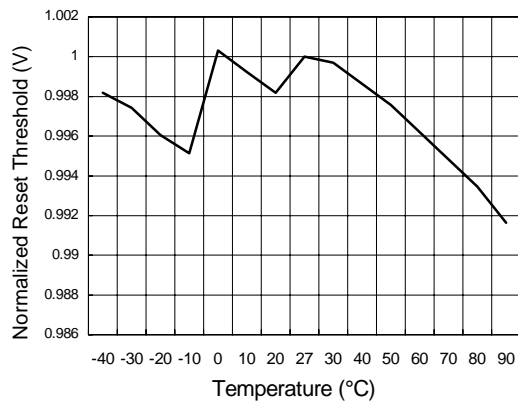

## Pin Description

PIN	NAME	FUNCTION
1	HTH	High-Voltage Threshold (Input): Analog input to a comparator. When the level on this pin initially rises above $V_{TH}$ , the delay generator cycles and the $\overline{RESET}$ remains low or RESET remains high for a minimum of 140ms.
2	GND	Ground
3	LTH	Low-Voltage Threshold (Input): Analog input to a comparator. This is the voltage monitor input assigned to detect a low voltage condition. When the level on this pin falls below $V_{TH}$ , $\overline{RESET}$ or RESET is asserted and the condition is latched until $V_{HTH} > V_{TH}$ .
4	$\overline{RESET}$ (RESET)	Reset (Output): Push-pull output. This output is asserted and latched when $V_{LTH} < V_{TH}$ , indicating a low voltage condition. This state remains latched until $V_{HTH} > V_{TH}$ . The polarity of this signal (active-high or low) is determined by the part number suffix. See ordering information.
5	$V_{CC}$	Power Supply (Input): Independent supply input for internal circuitry.

## Detailed Description

A microprocessor's ( $\mu P$ 's) reset input starts the  $\mu P$  in a known state. The G681L/G680L/G680H assert reset to prevent code-execution errors during power-up, power-down, or brownout conditions. They assert a reset signal whenever the threshold voltage declines below  $V_{TH}$ , keeping it asserted for at least 140ms after threshold voltage input has risen above the reset threshold. The G681L uses an open-drain output, and the G680L/G680H have a push-pull output stage. Connect a pull-up resistor on the G681L's  $\overline{RESET}$  output to any supply between 0 and 5.5V.

Battery voltage is monitored by a comparator via a voltage divider network. The divided voltage is compared to an internal reference voltage. When the voltage at the LTH input pin drops below the internal reference voltage, the output is asserted. At this point, the voltage at HTH is assumed to be below the reference voltage.

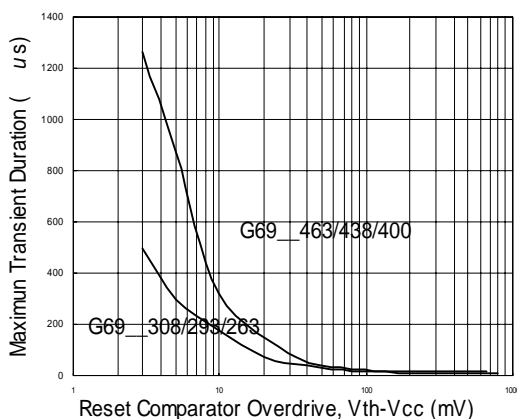

**Figure1. Maximum Transient Duration without Causing a Reset Pulse vs. Reset Comparator Overdrive**

## Applications Information

### Negative-Going $V_{CC}$ Transients

In addition to issuing a reset to the  $\mu P$  during power-up, power-down, and brownout conditions, the G681L/G680H/G680L are relatively immune to short-duration negative-going  $V_{LTH}$  transients (glitches).

Figure1. shows typical transient duration vs. reset comparator overdrive, for which the G681L/G680H/G680L do not generate a reset pulse. The graph was generated using a negative-going pulse applied to  $V_{LTH}$ , starting 0.1V above the actual reset threshold and ending below it by the magnitude indicated (reset comparator overdrive). The graph indicates the maximum pulse width a negative-going  $V_{LTH}$  transient can have without causing a reset pulse. As the magnitude of the transient increases (goes farther below the reset threshold), the maximum allowable pulse width decreases. Typically, a  $V_{LTH}$  transient that goes 100mV below the reset threshold and lasts 7 $\mu s$  or less will not cause a reset pulse. A 0.1 $\mu F$  bypass capacitor mounted as close as possible to the  $V_{LTH}$  pin provides additional transient immunity.

### Programming the Thresholds

The low-voltage threshold is calculated using:

$$V_{BAT (lo)} = V_{REF} \left( \frac{R1+R2+R3}{R2+R3} \right)$$

The low-voltage threshold is calculated using:

$$V_{BAT (hi)} = V_{REF} \left( \frac{R1+R2+R3}{R3} \right)$$

where, for both equations:

$$V_{BAT (hi)} = 1.245V$$

In order to provide the additional criteria needed to solve for the resistor values, the resistors can be selected such that they have a given total value, that is,  $R1 + R2 + R3 = R_{TOTAL}$ .

A value such as 1MΩ for R<sub>TOTAL</sub> is a reasonable value because it draws minimum battery current but has no measurable effect on accuracy.

When working with large resistors, a small amount of leakage current can cause voltage offsets that degrade system accuracy.

The maximum recommended total resistance from V<sub>BAT</sub> to ground is 3MΩ.

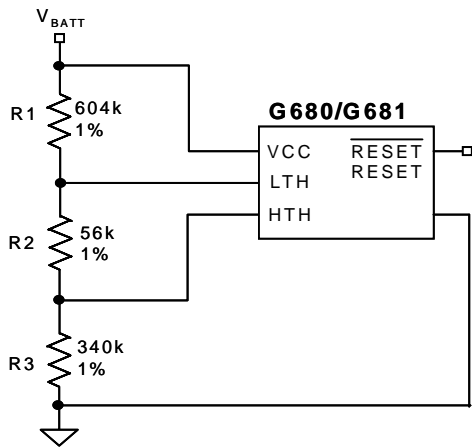

**Figure 2. Example Circuit**

Once the desired trip points are determined, set the V<sub>BAT(hi)</sub> threshold first.

For example, use a total of 1M = R1 + R2 + R3. For a typical single-cell lithium ion battery, 3.6V is a good “high threshold” because at 3.6V the battery is moderately charged. Solving for R3:

$$V_{BAT (hi)} = 1.245 \left( \frac{1M\Omega}{R3} \right)$$

R3 = 344kΩ

Once R3 is determined, the equation for V<sub>BAT (lo)</sub> can be used to determine R2. A single lithium-ion cell should not be discharged below 2.5V. Many applications limit the drain to 3.1V. Using 3.1V for the V<sub>BAT (lo)</sub> threshold allows calculation of the two remaining resistor values.

$$V_{BAT (lo)} = 3.1V = 1.245 \left( \frac{1M\Omega}{R2+344k} \right)$$

R2 = 56kΩ

R1 = 1MΩ - R2 - R3

R1 = 600kΩ

The accuracy of the resistors can be chosen based upon the accuracy required by the system.

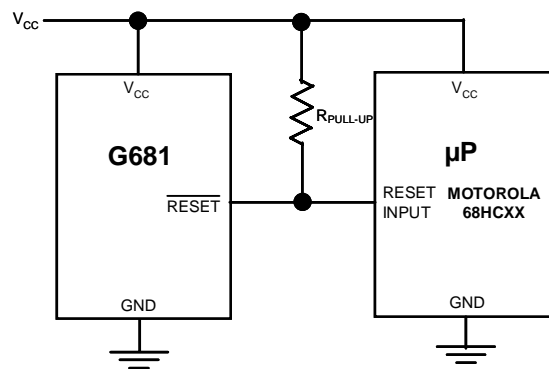
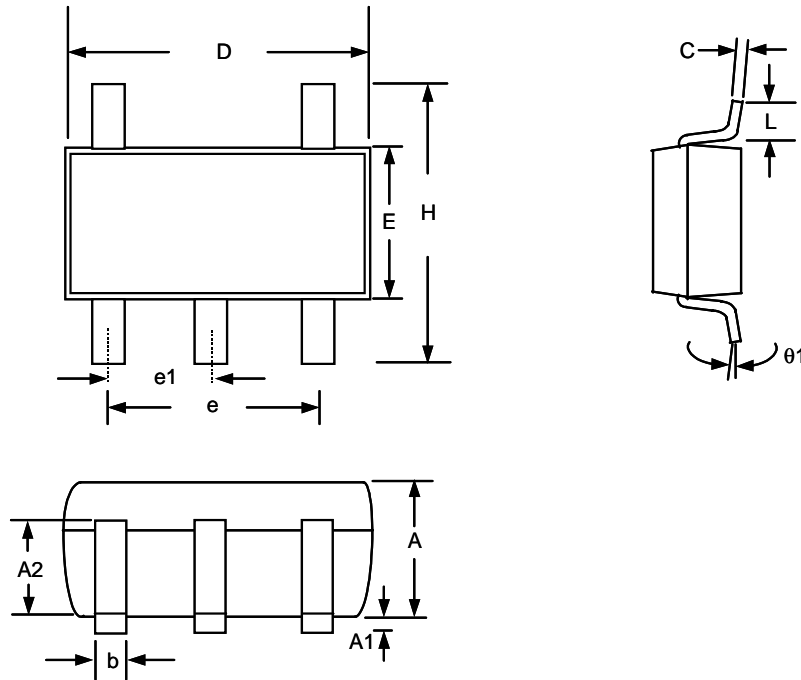

**Figure 3. Interfacing to μPs with Bidirectional Reset I/O**

**Interfacing to μPs with Bidirectional Reset Pins**

Since the  $\overline{\text{RESET}}$  output on the G681L is open drain, this device interfaces easily with μPs that have bidirectional reset pins, such as the Motorola 68HC11. Connecting the μP supervisor’s  $\overline{\text{RESET}}$  output directly to the microcontroller’s (μC’s)  $\overline{\text{RESET}}$  pin with a single pull-up resistor allows either device to assert reset (Figure 3).

## Package Information



**Note:**

1. Package body sizes exclude mold flash protrusions or gate burrs
2. Tolerance  $\pm 0.1000$  mm (4mil) unless otherwise specified
3. Coplanarity: 0.1000mm
4. Dimension L is measured in gage plane

SYMBOLS	DIMENSIONS IN MILLIMETERS		
	MIN	NOM	MAX
A	1.00	1.10	1.30
A1	0.00	-----	0.10
A2	0.70	0.80	0.90
b	0.35	0.40	0.50
C	0.10	0.15	0.25
D	2.70	2.90	3.10
E	1.40	1.60	1.80
e	-----	1.90(TYP)	-----
e1	-----	0.95	-----
H	2.60	2.80	3.00
L	0.37	-----	-----
$\theta 1$	1°	5°	9°

## Taping Specification

