



## 1.8W TO 8W STEP-DOWN SWITCHING REGULATOR FAMILY

PRELIMINARY

### FEATURE

- MTBF 1 000 000 hours ( $T_{amb}=25^{\circ}C$ )
- 1.5A max output current
- 16V max input voltage
- 1.5V max drop-out voltage
- Remote logic inhibit/enable
- Not-latching overload and short circuit protection
- Thermal shutdown
- Fixed or adjustable output
- No heatsink required

### DESCRIPTION

The GS-R12P series is a family of high efficiency step down switching voltage regulator, designed to replace linear regulators.

Based on STM L5973 device, this non isolated family of regulators are suitable for the full spectrum of applications including telecom, industry, computer and distributed power system applications having a widely ranging input voltage.

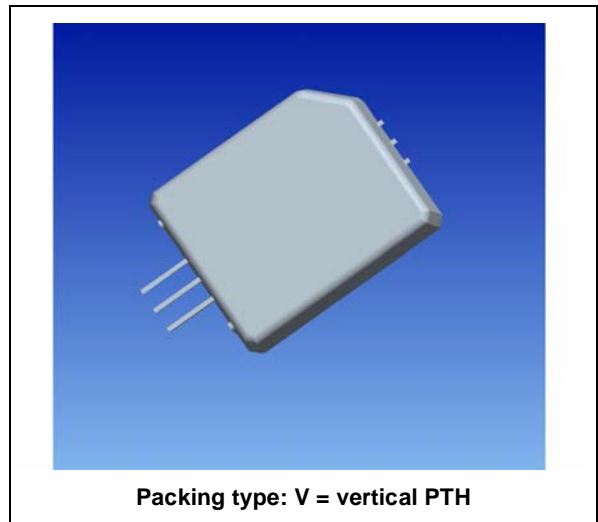

## GS-R12P

### SELECTION CHART

Type Ordering Number	Output Voltage [V]	Input Voltage [V]	Output Ripple [mVpp]	Efficiency [%]	Package (P)*	Notes
GS-R12(P)0181.5	1.8 ± 4%	4.5 ÷ 15	35	72	H-S-V	Fixed output voltage
GS-R12(P)0251.5	2.5 ± 4%	4.5 ÷ 15	35	76	H-S-V	Fixed output voltage
GS-R12(P)0331.5	3.3 ± 4%	4.5 ÷ 15	35	82	H-S-V	Fixed output voltage
GS-R12(P)0501.5	5.0 ± 4%	6.6 ÷ 15	35	85	H-S-V	Fixed output voltage
GS-R12(P)0001.5	1.235 ÷ 5.5	4.5 ÷ 15	35	68 ÷ 85	H-S	Progr. output voltage

\* Packing Legend (P)

H = horizontal through hole

S = horizontal SMD

V = vertical through hole

### ABSOLUTE MAXIMUM RATINGS

Symbol	Parameter	Value	Unit
$V_i$	DC Input Voltage (for GS-R12(P)XXX1.5)	16	V
$I_{out}$	Maximum Output Current	int. limit	
$V_4$	INH	-0.3 to $V_i$	V
$V_6$	FB	4	V
$T_{stg}$	Storage Temperature Range	-40 ÷ 105	°C
$T_{op}$	Operating Ambient Temperature	-25 ÷ 70	°C
$T_{op1}$	Operating Ambient Temperature with current derating	-25 ÷ 85	°C

CONNECTION DIAGRAM AND MECHANICAL DATA

GS-R12VXXX1.5

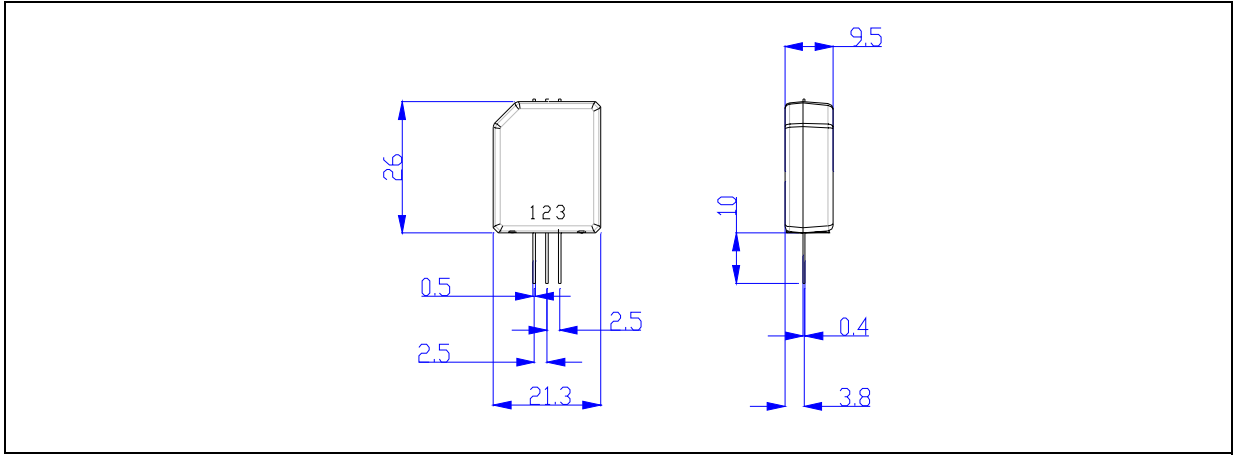

GS-R12HXXX1.5

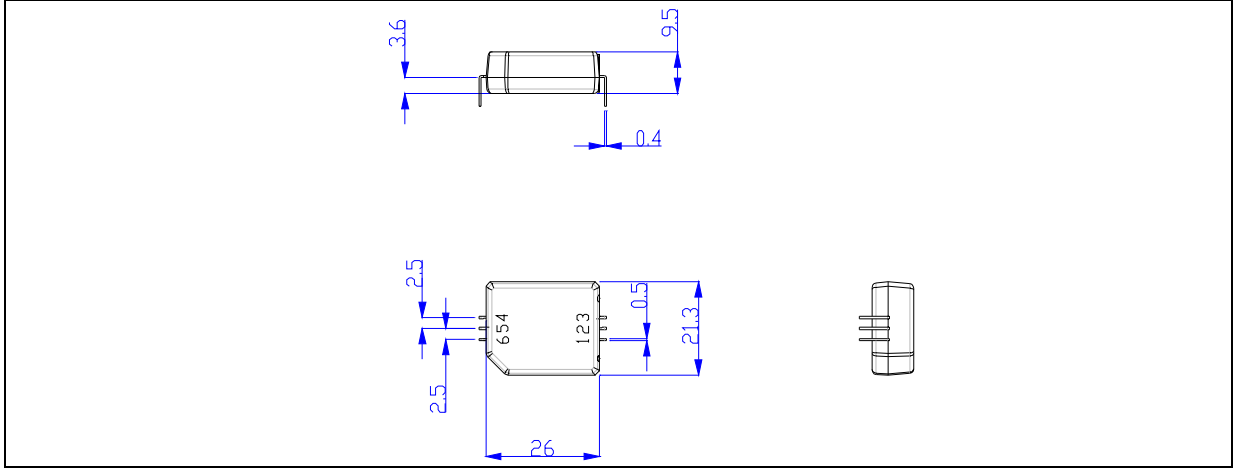

GS-R12SXXX1.5

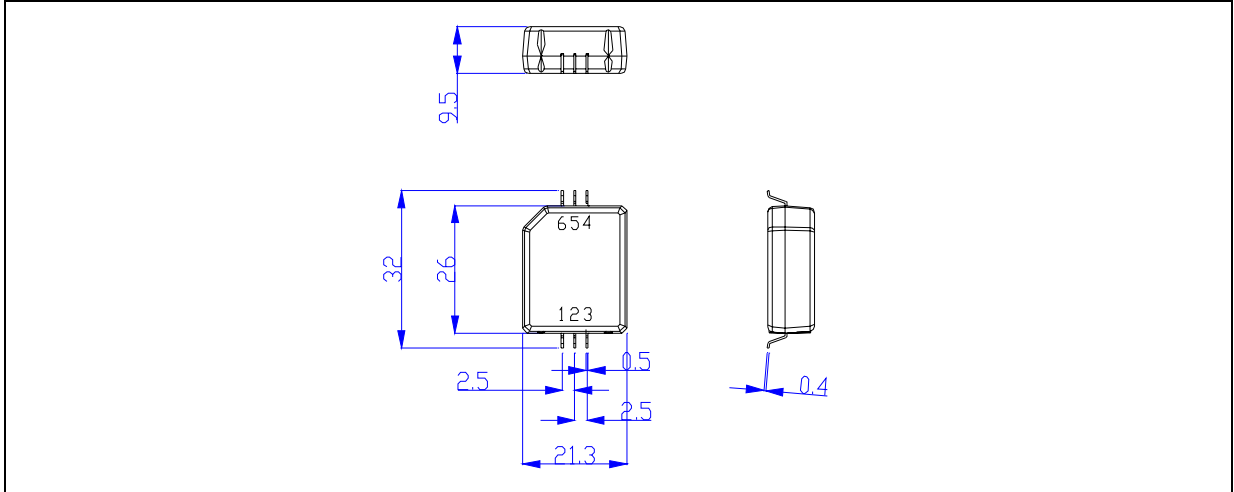

## GS-R12P

### PIN DESCRIPTION

Pin	Function	Description
1	Input +	DC input voltage
2	Input/Output GND	Return for input/output voltage source
3	$V_{out}$	Regulated power output
4	INH	A logical level (active high) disables the device, when it is open an internal pull up disables the device
5	$V_{out-c}$	Regulated output point for additional compensation
6	FB	Feedback input, available on adjustable device and on request for additional compensation

### ELECTRICAL CHARACTERISTICS All versions ( $T_{amb}=25^{\circ}C$ , unless otherwise specified.)

Symbol	Parameter	Test Condition	Min.	Typ.	Max.	Unit
$V_r$	Ripple Voltage	$V_i=12V I_o=1.5A$		35		mVpp
	Temperature Stability	$V_i=V_o+1.5V I_o=1.5A$				mV/°C
$I_o$	Output Current	$V_i=4.5 \div 16V$	0		1.5	A
$I_{oL}$	Current Limit	$V_i=4.5 \div 16V$		2.5		A
$I_q$	Quiescent Current	$V_i=12V I_o=0A$		1.8	2.5	mA
$f_s$	Switching Frequency	$V_i=12V I_o=1.5A$	225	250	275	kHz
SRV	Supply Voltage Rejection					mV/V
$R_{th}$	Thermal Resistance	Case to ambient				°C/W

### ELECTRICAL CHARACTERISTICS for horizontal versions only ( $T_{amb}=25^{\circ}C$ , unless otherwise specified.)

Symbol	Parameter	Test Condition	Min.	Typ.	Max.	Unit
$I_{qst-by}$	Total Stand-by Quiescent Current	$V_{inh}>2.2V V_i=15V$		50	100	$\mu A$
INH	INH Threshold Voltage	Device ON			0.8	V
		Device OFF	2.2			V
$V_{FB}$	Feedback Voltage	$V_i=4.5 \div 15V I_o=0 \div 1.5A$	1.22	1.235	1.25	V

## USER NOTES

### Input Voltage

The recommended operating maximum DC Input Voltage is 15V inclusive of ripple voltage.

### Inhibit function

The inhibit feature allows to put in stand-by mode the device.

With INH pin 4 higher than 2.2V the device is disabled and the power consumption is reduced to less than 100 $\mu$ A for  $V_i = 15V$ .

With INH pin lower than 0.8V, the device is enabled.

If the INH pin is left floating, an internal pull up ensures that the voltage at the pin reaches the inhibit threshold and the device is disabled.

The pin is also  $V_i$  compatible.

### Current protection

The device has two current limit protections, pulse by pulse and frequency fold back.

The current is sensed through a resistor and if reaches the threshold, the on time is reduced and consequently the output voltage too.

Since the minimum switch ON time (necessary to avoid false overcurrent signal) is not enough to obtain a sufficiently low duty cycle at 250 Hz, the output current, in strong overcurrent or short circuit conditions, could increase again.

For this reason the switching frequency is also reduced, so keeping the inductor current under its maximum threshold.

The frequency depends on the feedback voltage.

As the feedback voltage decreases (due to the reduced duty cycle), the switching frequency decrease too.

### Thermal shutdown

The shutdown block generates a signal that turns off the power stage if the temperature of the internal chip goes higher than a fixed internal threshold (150 °C).

The sensing element of the chip is very close to the PDMOS area, so ensuring an accurate and fast temperature detection.

An hysteresis of approximately 20°C avoids that the devices turns on and off continuously.

### Thermal Characteristics

#### Output voltage programming (GS-R12H(S)0001.5 only)

The GS-R12P output voltage is 5.54V  $\pm$ 4%, to reduce this value connect a resistor between pin 6 (FB) and pin 5 ( $V_{out-c}$ ).

The resistor must be located very close to the proper pins, to minimize the injected noise (see figure 1).

The resistor value is calculated using the following formula:

$$R_v = [(V_{out} - 1.235) * 11.3] / (5.54 - V_{out}) \quad [\text{k}\Omega]$$

$V_{out}$  can be adjusted between 1.235V ( $R_v=0 \Omega$ ) and 5.54V ( $R_v=\text{open}$ )

## GS-R12P

---

### Loop compensation (GS-R12H(S)0001.5 only)

If required by particular load conditions, it is possible to change the feedback loop compensation, adding an external capacitor between pin 6 (FB) and pin 5 ( $V_{out-c}$ ), which will act as speed up (see figure 2).

## ADDITIONAL FEATURES AND PROTECTIONS

### Feedback disconnection

In case of feedback disconnection, the duty cycle increases versus the maximum allowed value, bringing the output voltage close to the input supply.

This condition could destroy the load.

To avoid this dangerous condition, the device is turned off if the internal feedback pin remains floating.

### Output overvoltage protection

The overvoltage protection, OVP, is realized by using an internal comparator, which input is connected to the feedback, that turns off the power stage when the OVP threshold is reached.

This threshold is typically 30% higher than the feedback voltage.

Figure 1

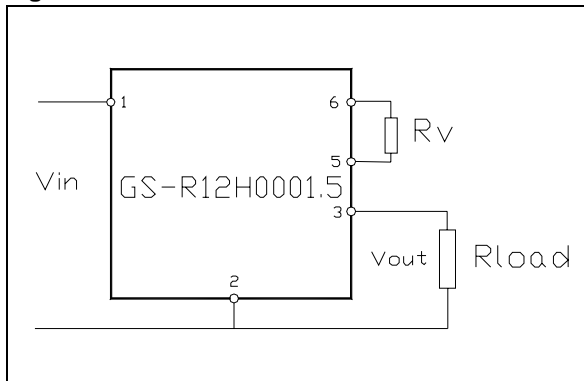
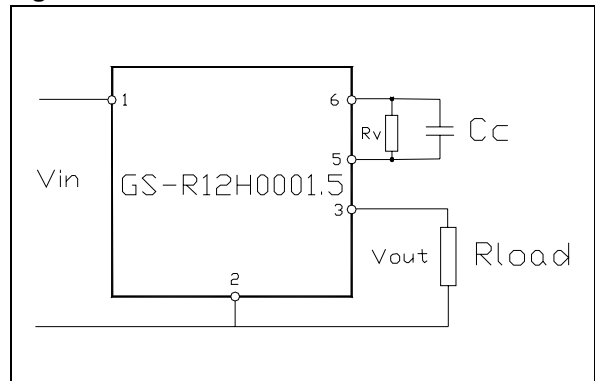

Figure 2



Information furnished is believed to be accurate and reliable. However, STMicroelectronics assumes no responsibility for the consequences of use of such information nor for any infringement of patents or other rights of third parties which may result from its use. No license is granted by implication or otherwise under any patent or patent rights of STMicroelectronics. Specifications mentioned in this publication are subject to change without notice. This publication supersedes and replaces all information previously supplied. STMicroelectronics products are not authorized for use as critical components in life support devices or systems without express written approval of STMicroelectronics.

The ST logo is a registered trademark of STMicroelectronics.  
All other names are the property of their respective owners

© 2004 STMicroelectronics - All Rights Reserved

STMicroelectronics GROUP OF COMPANIES

Australia - Belgium - Brazil - Canada - China -Czech Republic - Finland - France - Germany - Hong Kong - India - Israel - Italy - Japan  
- Malaysia - Malta - Morocco - Singapore - Spain - Sweden - Switzerland - United Kingdom - U.S.A.  
<http://www.st.com>