

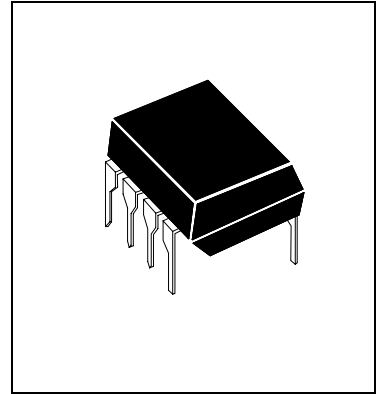

H393P

LOW POWER LOW OFFSET VOLTAGE COMPARATORS



Description

The H393P series consists of two independent precision voltage comparators designed specifically to operate from a single power supply over a wide range of voltages, the input common mode voltage range includes ground. Owing to adoption of clamp circuitry in input pins, misoperation is prevented by negative input.

Features

- Wide power supply voltage range
 Single power supply 2 V to 30 V
 Dual power supplies ± 1 V to ± 15 V
- Wide input common-mode voltage range 0 V to $(V_{cc}-1.5)$ V
- Low input bias current 25 nA typ.
- High sink current capability because of open collector output 40mA min.

Pin Configurations

	Pin 1 : Output A	Pin 5 : + Input B
	Pin 2 : - Input A	Pin 6 : - Input B
	Pin 3 : + Input A	Pin 7 : Output B
	Pin 4 : GND	Pin 8 : Vcc

Equivalent Circuit

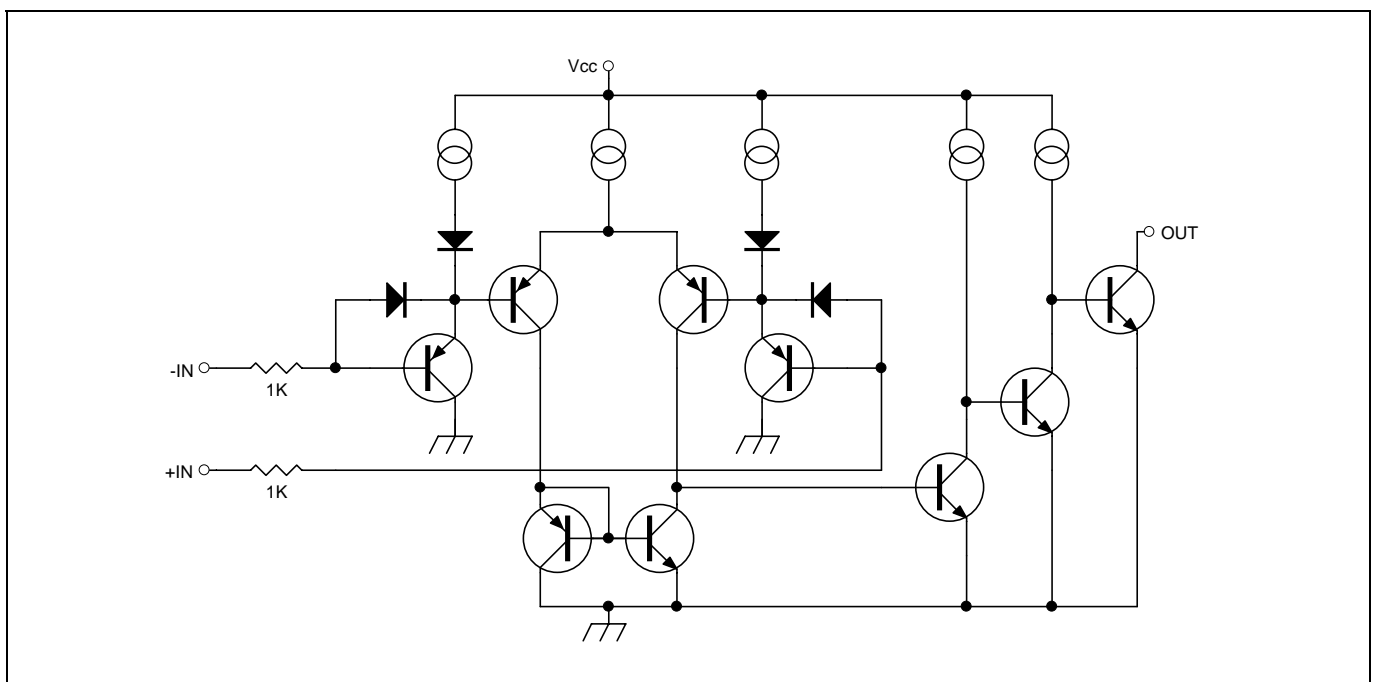



Absolute Maximum Ratings (see Note)

Rating	Symbol	Value	Unit
Power Supply Voltage	VCC	36	V
Differential Input Voltage	VID	36	V
Common-Mode Input Voltage	VI	-5 to 36	V
Output Short Current to GND	-	Infinite*	-
Power Dissipation	PD	350 (Ta≤55°C)	mW
Operating Temperature	Ta	-20 to +75	°C
Storage Temperature	Tstg	-55 to +125	°C

*: This value is specified with respect to the short circuit from output to GND. However, short circuit from the output to VCC cause device destruction.

Note: Permanent device damage may occur if the above Absolute Maximum Ratings are exceeded. Functional operation should be restricted to the conditions as detailed in the operational sections of this data sheet. Exposure to absolute maximum rating conditions for extended periods may affect device reliability.

Recommended Operating Conditions

Rating	Symbol	Value	Unit
Power Supply Voltage	VCC	2 to 30	V
		±1.0 to ±15	
Operating Temperature	Ta	-20 to +75	°C
Output Sink Current	Isink	≤40	mA

Electrical Characteristics (Vcc=5V, Ta=25°C)

Parameter	Symbol	Conditions	Value			Units
			Min	Typ	Max	
Input Offset Voltage	Vio	Vo=VREF=1.4V	-	2	5	mV
Input Offset Current	Iio	-	-	5	50	nA
Input Bias Current	Iin*1	-	-	25	250	nA
Common-Mode Input Voltage	Vcm*2	-	0	-	Vcc-1.5	V
Power Supply Current	Icc	RL=∞	-	2	3	mA
Voltage Gain	Av	RL=15kΩ, Vcc=15V	-	200	-	V/mV
Response Time	-	RL=1kΩ	-	2	-	us
Output Sink Current	Isink	Vin(+)=0, Vin(-)=1V, Vol≤1.5V	40	-	-	mA
Output Saturation Voltage	Vol	Vin(+)=0, Vin(-)=1V, Isink≤30mA	-	0.2	0.4	V
Output Leakage Current	Ileak	Vin(+)=1V, Vin(-)=0, Vo=30V	-	-	1	uA

Notes:

*1: Iin is measured when Vi≥0 and direction of the input current flows from IC. When negative voltage is applied to input pin, the pin is equivalently connected the GND through a 1kΩ of resistor.
 When low voltage below than -5V is applied, please connect a resistor serially to input pin in order to prevent the high current flow.

*2: Positive input voltage may exceed the power supply voltage. As long as the other voltage remains in the common-mode input voltage range, the comparator will provide a proper output state.
 When Vcc=5V, your are requested to use Vin below 25V.



DIP-8P Dimension

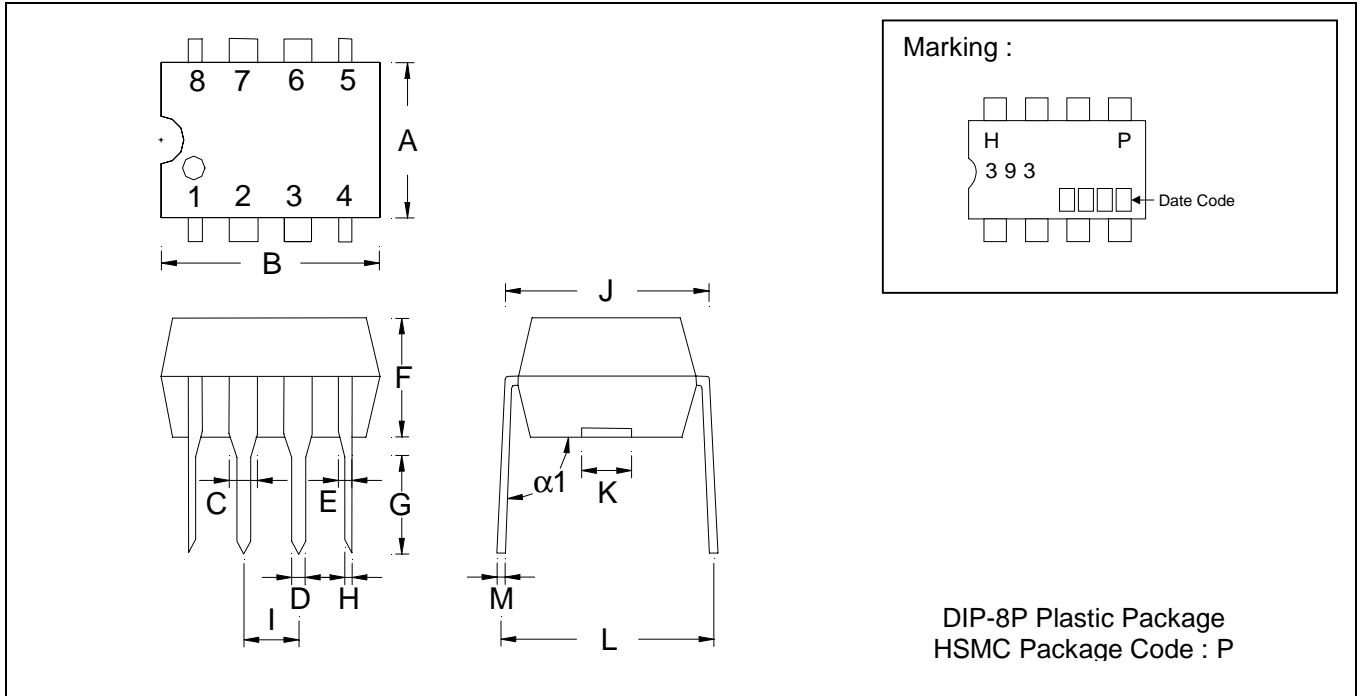

*:Typical

DIM	Inches		Millimeters		DIM	Inches		Millimeters	
	Min.	Max.	Min.	Max.		Min.	Max.	Min.	Max.
A	0.2480	0.2520	6.29	6.40	H	0.0150	0.0210	0.38	0.53
B	0.3630	0.3670	9.22	9.32	I	0.0898	0.1098	2.28	2.79
C	-	*0.0600	-	*1.52	J	0.2950	0.3050	7.49	7.74
D	-	*0.0500	-	*1.27	K	-	*0.1181	-	*3.00
E	-	*0.0390	-	*0.99	L	0.3370	0.7470	8.56	8.81
F	0.1280	0.1320	3.25	3.35	M	0.0090	0.0150	0.229	0.381
G	0.1250	0.1400	3.17	3.55	$\alpha 1$	94°	97°	94°	97°

- Notes : 1.Dimension and tolerance based on our Spec. dated Sep. 07,1997.
 2.Controlling dimension : millimeters.
 3.Maximum lead thickness includes lead finish thickness, and minimum lead thickness is the minimum thickness of base material.
 4.If there is any question with packing specification or packing method, please contact your local HSMC sales office.

Material :

- Lead : 42 Alloy ; solder plating
- Mold Compound : Epoxy resin family, flammability solid burning class:UL94V-0

Important Notice :

- All rights are reserved. Reproduction in whole or in part is prohibited without the prior written approval of HSMC.
- HSMC reserves the right to make changes to its products without notice.
- **HSMC semiconductor products are not warranted to be suitable for use in Life-Support Applications, or systems.**
- HSMC assumes no liability for any consequence of customer product design, infringement of patents, or application assistance.

Head Office And Factory :

- **Head Office** (Hi-Sincerity Microelectronics Corp.) : 10F.,No. 61, Sec. 2, Chung-Shan N. Rd. Taipei Taiwan R.O.C.
 Tel : 886-2-25212056 Fax : 886-2-25632712, 25368454
- **Factory 1** : No. 38, Kuang Fu S. Rd., Fu-Kou Hsin-Chu Industrial Park Hsin-Chu Taiwan. R.O.C
 Tel : 886-3-5983621~5 Fax : 886-3-5982931