

---

# HD74ALVC1G86

2-input Exclusive-OR Gate

## HITACHI

ADE-205-608A (Z)  
2nd. Edition  
March 2001

---

### Description

The HD74ALVC1G86 performs the Boolean functions  $Y = A \oplus B$  or  $Y = \overline{A}B + A\overline{B}$  in positive logic. A common application is as a true / complement element. If one of the inputs is low, the other input will be reproduced in true form at the output. If one of the inputs is high, the signal on the other input will be reproduced inverted form at the output. Low voltage and high speed operation is suitable for the battery powered products (e.g., notebook computers), and the low power consumption extends the battery life.

### Features

- The basic gate function is lined up as hitachi uni logic series.
- Supplied on emboss taping for high speed automatic mounting.
- Supply voltage range : 1.2 to 3.6 V  
Operating temperature range : -40 to +85°C
- All inputs  $V_{IH}$  (Max.) = 3.6 V (@  $V_{CC} = 0$  V to 3.6 V)  
All outputs  $V_O$  (Max.) = 3.6 V (@  $V_{CC} = 0$  V)
- Output current  $\pm 2$  mA (@  $V_{CC} = 1.2$  V)
  - $\pm 4$  mA (@  $V_{CC} = 1.4$  V to 1.6 V)
  - $\pm 6$  mA (@  $V_{CC} = 1.65$  V to 1.95 V)
  - $\pm 18$  mA (@  $V_{CC} = 2.3$  V to 2.7 V)
  - $\pm 24$  mA (@  $V_{CC} = 3.0$  V to 3.6 V)

# HD74ALVC1G86

## Outline and Article Indication

• HD74ALVC1G86

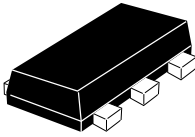

VSON-5

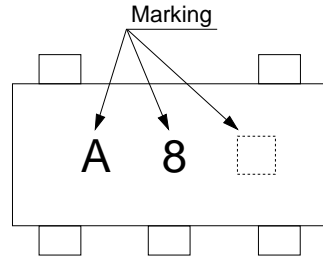

□ = Control code

## Function Table

Inputs		Output Y
A	B	
L	L	L
L	H	H
H	L	H
H	H	L

H : High level

L : Low level

## Pin Arrangement

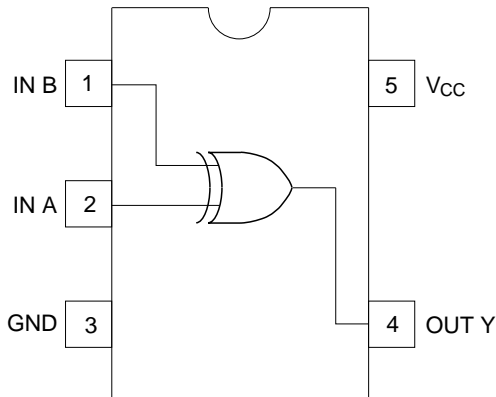

(Top view)

**Absolute Maximum Ratings**

Item	Symbol	Ratings	Unit	Test Conditions
Supply voltage range	$V_{CC}$	-0.5 to 4.6	V	
Input voltage range <sup>*1</sup>	$V_I$	-0.5 to 4.6	V	
Output voltage range <sup>*1,2</sup>	$V_O$	-0.5 to $V_{CC} + 0.5$ -0.5 to 4.6	V	Output : H or L $V_{CC}$ : OFF
Input clamp current	$I_{IK}$	-50	mA	$V_I < 0$
Output clamp current	$I_{OK}$	$\pm 50$	mA	$V_O < 0$ or $V_O > V_{CC}$
Continuous output current	$I_O$	$\pm 50$	mA	$V_O = 0$ to $V_{CC}$
Continuous current through $V_{CC}$ or GND	$I_{CC}$ or $I_{GND}$	$\pm 100$	mA	
Maximum power dissipation at $T_a = 25^\circ\text{C}$ (in still air) <sup>*3</sup>	$P_T$	200	mW	
Storage temperature	Tstg	-65 to 150	$^\circ\text{C}$	

Notes: The absolute maximum ratings are values which must not individually be exceeded, and furthermore no two of which may be realized at the same time.

1. The input and output voltage ratings may be exceeded if the input and output clamp-current ratings are observed.
2. This value is limited to 4.6 V maximum.
3. The maximum package power dissipation was calculated using a junction temperature of  $150^\circ\text{C}$ .

**Recommended Operating Conditions**

Item	Symbol	Min	Max	Unit	Conditions
Supply voltage range	$V_{CC}$	1.2	3.6	V	
Input voltage range	$V_I$	0	3.6	V	
Output voltage range	$V_O$	0	$V_{CC}$	V	
Output current	$I_{OH}$	—	-2	mA	$V_{CC} = 1.2\text{ V}$
		—	-4		$V_{CC} = 1.4\text{ V}$
		—	-6		$V_{CC} = 1.65\text{ V}$
		—	-18		$V_{CC} = 2.3\text{ V}$
		—	-24		$V_{CC} = 3.0\text{ V}$
	$I_{OL}$	—	2	$V_{CC} = 1.2\text{ V}$	
		—	4	$V_{CC} = 1.4\text{ V}$	
		—	6	$V_{CC} = 1.65\text{ V}$	
		—	18	$V_{CC} = 2.3\text{ V}$	
		—	24	$V_{CC} = 3.0\text{ V}$	
Input transition rise or fall rate	$\Delta t / \Delta v$	0	20	ns / V	$V_{CC} = 1.2\text{ to }2.7\text{ V}$
		0	10		$V_{CC} = 3.3 \pm 0.3\text{ V}$
Operating free-air temperature	$T_a$	-40	85	°C	

Note: Unused or floating inputs must be held high or low.

**Electrical Characteristic**

- Ta = -40 to 85°C

Item	Symbol	V <sub>CC</sub> (V) *	Min	Typ	Max	Unit	Test condition
Input voltage	V <sub>IH</sub>	1.2	V <sub>CC</sub> ×0.75	—	—	V	
		1.4 to 1.6	V <sub>CC</sub> ×0.7	—	—		
		1.65 to 1.95	V <sub>CC</sub> ×0.7	—	—		
		2.3 to 2.7	1.7	—	—		
		3.0 to 3.6	2.0	—	—		
	V <sub>IL</sub>	1.2	—	—	V <sub>CC</sub> ×0.25		
		1.4 to 1.6	—	—	V <sub>CC</sub> ×0.3		
		1.65 to 1.95	—	—	V <sub>CC</sub> ×0.3		
		2.3 to 2.7	—	—	0.7		
		3.0 to 3.6	—	—	0.8		
Output voltage	V <sub>OH</sub>	Min to Max	V <sub>CC</sub> -0.2	—	—	V	I <sub>OH</sub> = -100 μA
		1.2	0.9	—	—		I <sub>OH</sub> = -2 mA
		1.4	1.1	—	—		I <sub>OH</sub> = -4 mA
		1.65	1.2	—	—		I <sub>OH</sub> = -6 mA
		2.3	1.7	—	—		I <sub>OH</sub> = -18 mA
		3.0	2.2	—	—		I <sub>OH</sub> = -24 mA
	V <sub>OL</sub>	Min to Max	—	—	0.2	I <sub>OL</sub> = 100 μA	
		1.2	—	—	0.3	I <sub>OL</sub> = 2 mA	
		1.4	—	—	0.3	I <sub>OL</sub> = 4 mA	
		1.65	—	—	0.3	I <sub>OL</sub> = 6 mA	
		2.3	—	—	0.55	I <sub>OL</sub> = 18 mA	
		3.0	—	—	0.55	I <sub>OL</sub> = 24 mA	
Input current	I <sub>IN</sub>	3.6	—	—	±5	μA	V <sub>IN</sub> = 3.6 V or GND
Quiescent supply current	I <sub>CC</sub>	3.6	—	—	10	μA	V <sub>IN</sub> = V <sub>CC</sub> or GND, I <sub>O</sub> = 0
Output leakage current	I <sub>OFF</sub>	0	—	—	5	μA	V <sub>I</sub> or V <sub>O</sub> = 0 to 3.6 V
Input capacitance	C <sub>IN</sub>	3.3	—	2.5	—	pF	V <sub>IN</sub> = V <sub>CC</sub> or GND

Note: For conditions shown as Min or Max, use the appropriate values under recommended operating conditions.

**Switching Characteristics**

- $V_{CC} = 1.2 \text{ V}$

Item	Symbol	$T_a = -40 \text{ to } 85^\circ\text{C}$			Unit	Test Conditions	FROM (Input)	TO (Output)
		Min	Typ	Max				
Propagation delay time	$t_{PLH}$ $t_{PHL}$	—	7.5	—	ns	$C_L = 15 \text{ pF}$	A or B	Y

- $V_{CC} = 1.5 \pm 0.1 \text{ V}$

Item	Symbol	$T_a = -40 \text{ to } 85^\circ\text{C}$			Unit	Test Conditions	FROM (Input)	TO (Output)
		Min	Typ	Max				
Propagation delay time	$t_{PLH}$ $t_{PHL}$	2.0	—	8.0	ns	$C_L = 15 \text{ pF}$	A or B	Y

- $V_{CC} = 1.8 \pm 0.15 \text{ V}$

Item	Symbol	$T_a = -40 \text{ to } 85^\circ\text{C}$			Unit	Test Conditions	FROM (Input)	TO (Output)
		Min	Typ	Max				
Propagation delay time	$t_{PLH}$ $t_{PHL}$	1.5	—	6.0	ns	$C_L = 30 \text{ pF}$	A or B	Y

- $V_{CC} = 2.5 \pm 0.2 \text{ V}$

Item	Symbol	$T_a = -40 \text{ to } 85^\circ\text{C}$			Unit	Test Conditions	FROM (Input)	TO (Output)
		Min	Typ	Max				
Propagation delay time	$t_{PLH}$ $t_{PHL}$	1.0	—	4.0	ns	$C_L = 30 \text{ pF}$	A or B	Y

- $V_{CC} = 3.3 \pm 0.3 \text{ V}$

Item	Symbol	$T_a = -40 \text{ to } 85^\circ\text{C}$			Unit	Test Conditions	FROM (Input)	TO (Output)
		Min	Typ	Max				
Propagation delay time	$t_{PLH}$ $t_{PHL}$	1.0	—	3.0	ns	$C_L = 30 \text{ pF}$	A or B	Y

Operating Characteristics

Item	Symbol	V <sub>CC</sub> (V)	T <sub>a</sub> = 25°C			Unit	Test Conditions
			Min	Typ	Max		
Power dissipation capacitance	C <sub>PD</sub>	1.5	—	10.5	—	pF	f = 10 MHz
		1.8	—	10.5	—		
		2.5	—	10.5	—		
		3.3	—	11.5	—		

Test Circuit

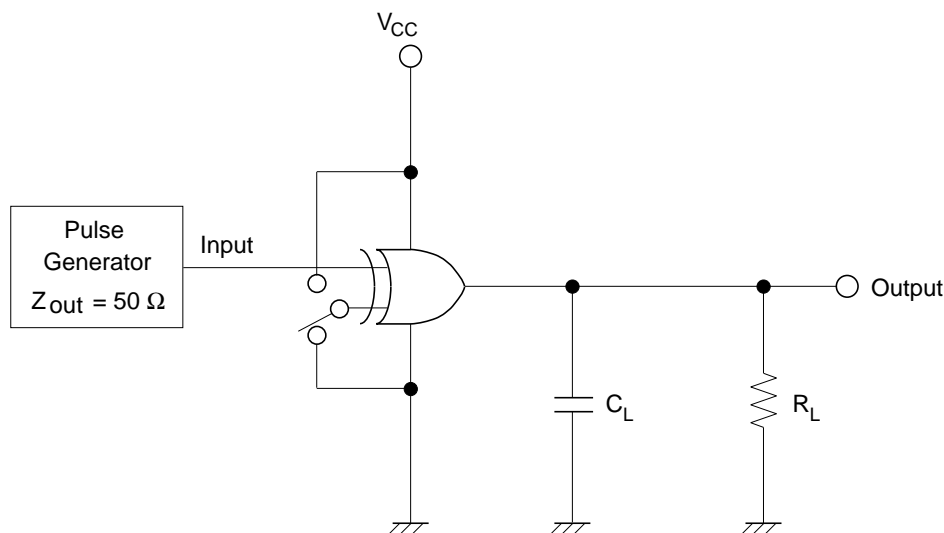

Symbol	V <sub>CC</sub> = 1.2 V, 1.5±0.1 V	V <sub>CC</sub> = 1.8±0.15 V	V <sub>CC</sub> = 2.5±0.2 V, 3.3±0.3 V
R <sub>L</sub>	2.0 kΩ	1.0 kΩ	500 Ω
C <sub>L</sub>	15 pF	30 pF	30 pF

Note: C<sub>L</sub> includes probe and jig capacitance.

• Waveforms

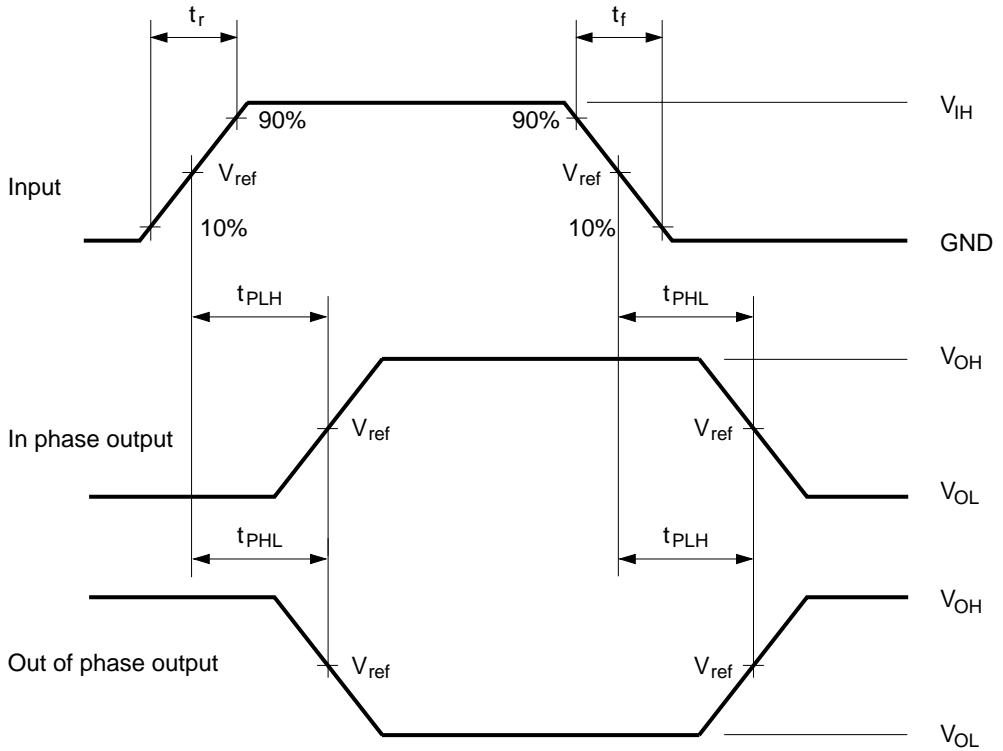

Symbol	$V_{CC} = 1.2 V,$ $1.5 \pm 0.1 V,$ $1.8 \pm 0.15 V$	$V_{CC} = 2.5 \pm 0.2 V$	$V_{CC} = 3.3 \pm 0.3 V$
$t_r / t_f$	2.0 ns	2.5 ns	2.5 ns
$V_{IH}$	$V_{CC}$	$V_{CC}$	2.7 V
$V_{ref}$	50%	50%	1.5 V

Note: Input waveform : PRR = 10 MHz, duty cycle 50%



Package Dimensions

As of January, 2001  
Unit: mm

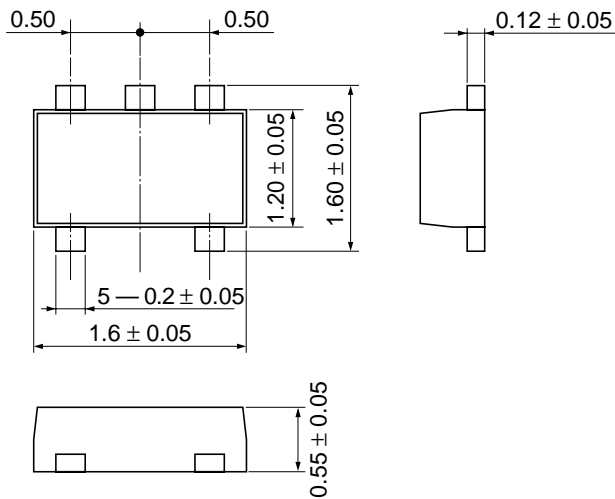

Hitachi Code	TNP-5D
JEDEC	—
EIAJ	—
Mass (reference value)	—

## Cautions

1. Hitachi neither warrants nor grants licenses of any rights of Hitachi's or any third party's patent, copyright, trademark, or other intellectual property rights for information contained in this document. Hitachi bears no responsibility for problems that may arise with third party's rights, including intellectual property rights, in connection with use of the information contained in this document.
2. Products and product specifications may be subject to change without notice. Confirm that you have received the latest product standards or specifications before final design, purchase or use.
3. Hitachi makes every attempt to ensure that its products are of high quality and reliability. However, contact Hitachi's sales office before using the product in an application that demands especially high quality and reliability or where its failure or malfunction may directly threaten human life or cause risk of bodily injury, such as aerospace, aeronautics, nuclear power, combustion control, transportation, traffic, safety equipment or medical equipment for life support.
4. Design your application so that the product is used within the ranges guaranteed by Hitachi particularly for maximum rating, operating supply voltage range, heat radiation characteristics, installation conditions and other characteristics. Hitachi bears no responsibility for failure or damage when used beyond the guaranteed ranges. Even within the guaranteed ranges, consider normally foreseeable failure rates or failure modes in semiconductor devices and employ systemic measures such as fail-safes, so that the equipment incorporating Hitachi product does not cause bodily injury, fire or other consequential damage due to operation of the Hitachi product.
5. This product is not designed to be radiation resistant.
6. No one is permitted to reproduce or duplicate, in any form, the whole or part of this document without written approval from Hitachi.
7. Contact Hitachi's sales office for any questions regarding this document or Hitachi semiconductor products.

# HITACHI

## Hitachi, Ltd.

Semiconductor & Integrated Circuits.  
Nippon Bldg., 2-6-2, Ohte-machi, Chiyoda-ku, Tokyo 100-0004, Japan  
Tel: Tokyo (03) 3270-2111 Fax: (03) 3270-5109

URL        NorthAmerica        : <http://semiconductor.hitachi.com/>  
             Europe                : <http://www.hitachi-eu.com/hel/ecg>  
             Asia                        : <http://sicapac.hitachi-asia.com>  
             Japan                        : <http://www.hitachi.co.jp/Sicd/indx.htm>

## For further information write to:

Hitachi Semiconductor (America) Inc.  
179 East Tasman Drive,  
San Jose, CA 95134  
Tel: <1> (408) 433-1990  
Fax: <1> (408) 433-0223

Hitachi Europe Ltd.  
Electronic Components Group.  
Whitebrook Park  
Lower Cookham Road  
Maidenhead  
Berkshire SL6 8YA, United Kingdom  
Tel: <44> (1628) 585000  
Fax: <44> (1628) 585200

Hitachi Europe GmbH  
Electronic Components Group  
Dornacher Straße 3  
D-85622 Feldkirchen, Munich  
Germany  
Tel: <49> (89) 9 9180-0  
Fax: <49> (89) 9 29 30 00

Hitachi Asia Ltd.  
Hitachi Tower  
16 Collyer Quay #20-00,  
Singapore 049318  
Tel : <65>-538-6533/538-8577  
Fax : <65>-538-6933/538-3877  
URL : <http://www.hitachi.com.sg>

Hitachi Asia Ltd.  
(Taipei Branch Office)  
4/F, No. 167, Tun Hwa North Road,  
Hung-Kuo Building,  
Taipei (105), Taiwan  
Tel : <886>-(2)-2718-3666  
Fax : <886>-(2)-2718-8180  
Telex : 23222 HAS-TP  
URL : <http://www.hitachi.com.tw>

Hitachi Asia (Hong Kong) Ltd.  
Group III (Electronic Components)  
7/F., North Tower,  
World Finance Centre,  
Harbour City, Canton Road  
Tsim Sha Tsui, Kowloon,  
Hong Kong  
Tel : <852>-(2)-735-9218  
Fax : <852>-(2)-730-0281  
URL : <http://semiconductor.hitachi.com.hk>

Copyright © Hitachi, Ltd., 2001. All rights reserved. Printed in Japan.

Colophon 3.0