

# HS - 101

HS - 101 are reflection sensors which aim at the human body detection such as ATM. HS - 101 has high resistance to ambient light by using modulated light. HS - 101 are installed with a screw and also can be connected very easily with 3 pin connector.

**FEATURES**

- Compact
- 3pin connector type

**APPLICATIONS**

- Human body detection for ATM etc

**DIMENSIONS**

(Unit : mm)

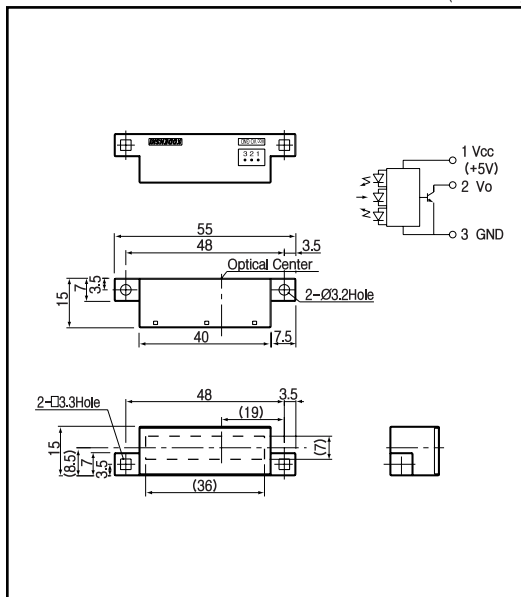

**MAXIMUM RATINGS**

(Ta=25 )

Item	Symbol	Rating	Unit
Supply voltage	V <sub>CC</sub>	5.5	V
Output voltage <sup>*1</sup>	V <sub>O</sub>	28	V
Low level output current <sup>*2</sup>	I <sub>OL</sub>	30	mA
Operating temp. <sup>*3*4</sup>	Topr.	- 10 +60	
Storage temp. <sup>*3*4</sup>	Tstg.	- 20 +70	

\*1. C - E voltage for output transistor  
 \*2. Collector current for output transistor  
 \*3. No icebound or dew  
 \*4. The connector shall be inserted or pulled out at normal temperature.

**ELECTRO-OPTICAL CHARACTERISTICS**

(Ta=25 )

Item	Symbol	Conditions	Min.	Typ.	Max.	Unit.
Supply voltage	V <sub>CC</sub>		4.75	5	5.25	V
Current consumption	I <sub>CC</sub>			6.5	12	mA
Low level output voltage	V <sub>OL</sub>	detecting V <sub>O</sub> =5V, R <sub>L</sub> =1k			0.2	V
High level output voltage	V <sub>OH</sub>	non detecting V <sub>O</sub> =5V, R <sub>L</sub> =1k	4.5			V
Detecting distance	L <sub>HL</sub>	reflection rate 90%, OFF ON 30cm x30cm	50	100	150	cm
Hysteresis	E <sub>VLH</sub> /E <sub>VHL</sub>	reflection rate 90%, 30cm x30cm		85		%
Response time	t	reflection rate 90%, L=50cm, 30cm x30cm		100	200	ms
Sun light	E <sub>VS</sub>	Luminous intensity at sensing area	10,000			lx
Incandescent light	E <sub>VT</sub>		3,000			lx
Fluorescent light	E <sub>VW</sub>		3,000			lx

## Reflective sensors

# HS - 101

### Detection area characteristics ( $V_{cc}=5V$ , $T_a=25, C$ )

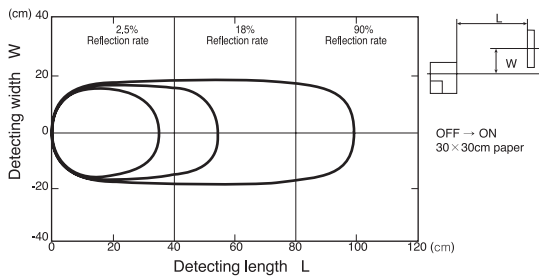
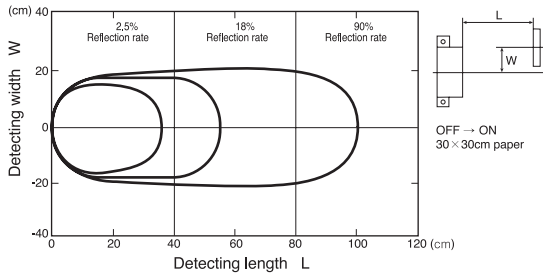

### Detection length / Ambient temp characteristics

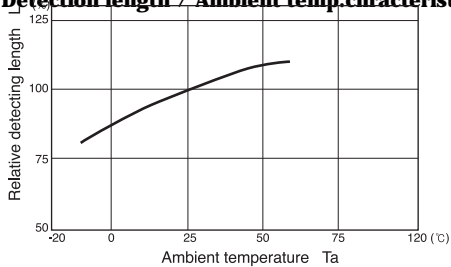

Reflection prevention seal is needed for installing a transparent panel to the front of HS-101. Also, the panel should be adhered to HS-101.

Quality level of HS-101 is set up on the assumption that main application of HS-101 is general electronic equipments, such as electric household products, O.A. equipments and A.V equipments.