

Features

- Operating voltage: 2.4V~5.5V
- Operating current: $3\mu\text{A}$ at 3.0V
- Constant voltage output (1.8V \pm 5%) at 2.4V~5.5V operating for driving lamp (1.8V/40mA)
- LCD contrast can not distort at 2.4V~5.5V operating
- LCD display drive 1/3 duty, 1/2 bias, frame frequency is 42.67Hz
- At power interrupt, data hold up > 1.0s (between V_{DD} and V_{SS} connect a 0.1 μF capacitor)
- Built-in power on reset function
- 32K crystal oscillator (Internal capacitor and resistor)
- Calendar and time adjustment
- Date imprinting modes (Y/M/D, D/H/Min, Imprint off, M/D/Y, D/M/Y)
- Mode is selected by cyclically turning
- 4 film printing times is selectable or external input control (30ms/45ms/60ms/external control)
- Direct resetting system
- Lamp output time control
- Provides module test circuit

General Description

The 6-Digital Timer is a camera data optical printer. Displaying and printing of data (Year Month Day/Day Hour: Minute/OFF/Month Day Year/Day Month Year) can be

selected by mode selection. Date updating is a fully automatic calendar from the year 1998.1.1 to 2049.12.31.

Block Diagram

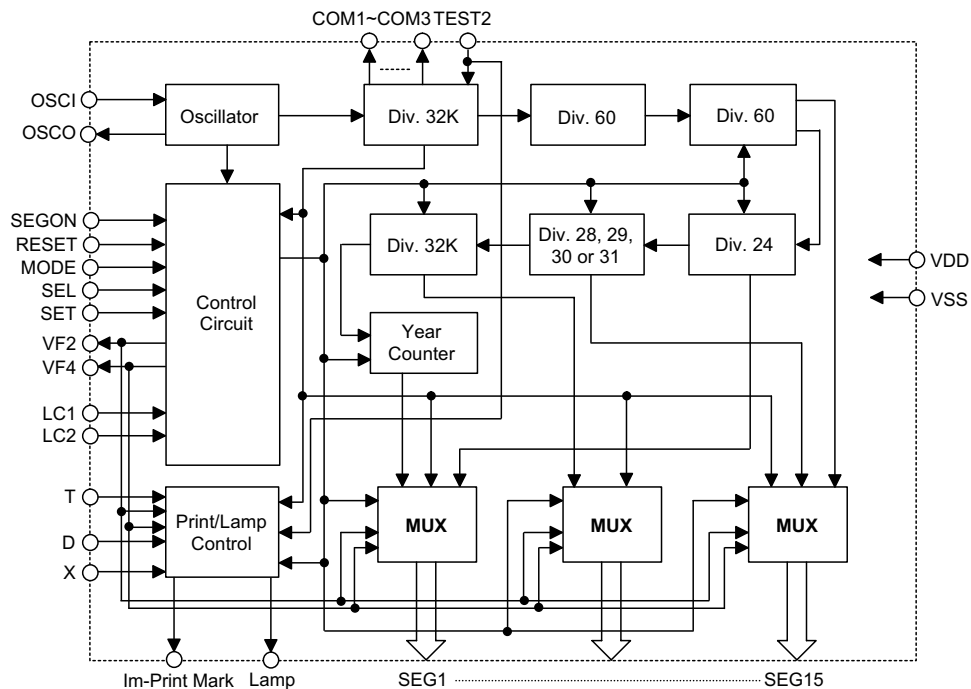

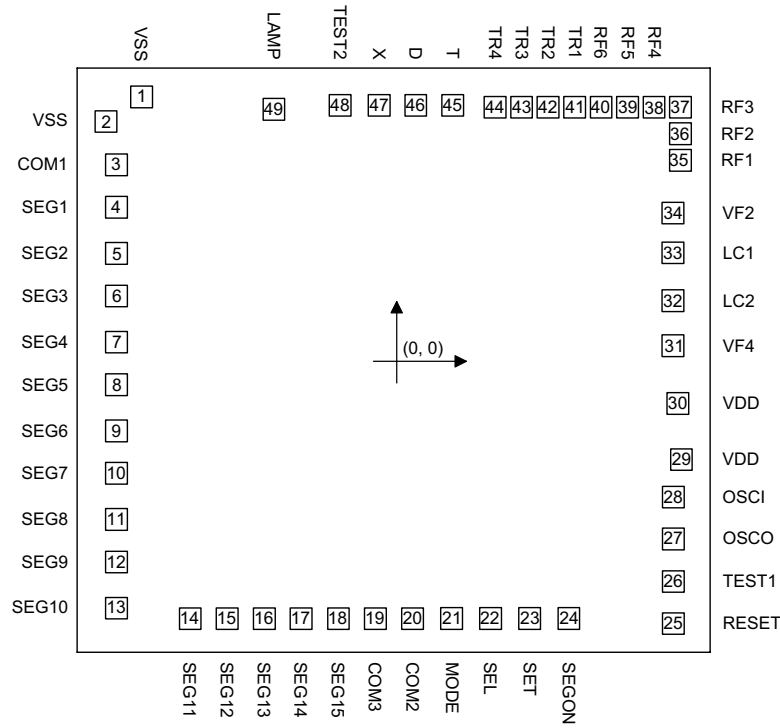
Pad Assignment

 Chip size: 2680 × 2460 (μm)²

Chip thickness=12 mil

* The IC substrate should be connected to VSS in the PCB layout artwork.

Pad Coordinates

Unit: μm

Pad No.	X	Y	Pad No.	X	Y
1	-1012.997	1050.624	26	1095.853	-872.226
2	-1154.997	952.474	27	1095.853	-704.226
3	-1112.447	781.274	28	1095.853	-537.226
4	-1112.447	612.274	29	1128.153	-388.926
5	-1112.447	429.374	30	1113.753	-167.026
6	-1112.447	260.374	31	1094.353	63.524
7	-1112.447	77.474	32	1094.353	241.524
8	-1112.447	-91.526	33	1094.353	431.524
9	-1112.447	-274.426	34	1094.353	589.524
10	-1112.447	-443.426	35	1124.553	798.974
11	-1112.447	-626.326	36	1124.553	903.974
12	-1112.447	-795.326	37	1124.553	1008.974
13	-1112.447	-978.226	38	1019.553	1008.974
14	-820.147	-1019.426	39	914.553	1008.974
15	-674.147	-1019.426	40	809.553	1008.974
16	-526.147	-1019.426	41	704.553	1008.974
17	-380.147	-1019.426	42	599.553	1008.974
18	-232.147	-1019.426	43	494.553	1008.974
19	-86.147	-1019.426	44	389.553	1008.974
20	61.853	-1019.426	45	221.853	1016.974
21	216.853	-1018.926	46	74.453	1016.974
22	371.853	-1018.926	47	-71.247	1016.974
23	526.853	-1018.926	48	-226.247	1016.974
24	681.853	-1018.926	49	-487.887	1001.224
25	1095.853	-1039.226			

Pad Description

Pad No.	Pad Name	I/O	Internal Connection	Description
1, 2	VSS	—	—	Negative power supply, ground
3, 19, 20	COM1 COM3, COM2	O	CMOS	Output for LCD panel common
4~18	SEG1~SEG15	O	CMOS	LCD segment output driver
21	MODE	I	CMOS with Pull-high	Mode select input pin (Internal pull-high 75K)
22	SEL	I	CMOS with Pull-high	Correction digit shift switch (Internal pull-high 75K)
23	SET	I	CMOS with Pull-high	Correction digit data (Internal pull-high 75K)
24	SEGON	I	CMOS with Pull-high	Est pin, if pull-low will force all segment "ON"
25	RESET	I	CMOS with Pull-low	External Reset input (Internal pull-low, 50K)
26	TEST1	I	CMOS with Pull-low	Test pin (not for customer)
27	OSCO	O	CMOS	Crystal oscillator output pin
28	OSCI	I	CMOS	Crystal oscillator input pin
29, 30	VDD	—	—	Positive power supply
31	VF4	O	CMOS	Double reference voltage
32, 33	LC2, LC1	I	CMOS	Connected to 0.1 μ F capacitor
34	VF2	O	CMOS	Reference voltage
35~40	RF1~RF6	I	—	Adjust regulator output voltage, TRIM PIN
41~44	TR1~TR4	I	—	Adjust constant voltage and drive lamp output pin (Open drain)
45	T	I	CMOS with Pull-high	Imprint time select input (Internal pull-high 75K with "Latch type")
46	D	I	CMOS with Pull-high	Imprint time external control input (Internal pull-high 75K with "Latch type")
47	X	I	CMOS with Pull-high	Imprint trigger input pin (Internal pull-high 75K)*
48	TEST2	I	CMOS with Pull-high	For customer test "PRINTING LCD" use only, pull-low will force Lamp "ON" and other function is OK (Internal pull-high 75K)**
49	LAMP	O	CMOS	Drive lamp output pin (Open drain)

Note: * The X input has no effect in OFF mode, selection and setting mode; the lamp will be turned off automatically.

** The TEST2 has no effect in selection and setting mode; the lamp will be turned off automatically.

Absolute Maximum Ratings

Supply Voltage5.5V Storage Temperature -20°C to 60°C
 Input Voltage 5.5V Operating Temperature.....0°C to 50°C
 Static Electricity (OFF Power).....200pF, \pm 200V, 10 times to each pin

Note: These are stress ratings only. Stresses exceeding the range specified under "Absolute Maximum Ratings" may cause substantial damage to the device. Functional operation of this device at other conditions beyond those listed in the specification is not implied and prolonged exposure to extreme conditions may affect device reliability.

Electrical Characteristics
 $T_a=25\pm 3^{\circ}\text{C}$, $\text{RH}\leq 65\%$, $V_{SS}=0\text{V}$

Symbol	Parameter	Test Conditions		Min.	Typ.	Max.	Unit
		V _{DD}	Conditions				
V _{DD}	Operating Voltage	—		2.4	3	5.5	V
V _{str}	Oscillation Start Voltage	3V	Within 2 sec after power on (Speed up oscillator when at power on reset)	2.4	—	—	V
V _{stop}	Oscillation Stop Voltage	3V		—	—	1.8	V
I _{opr1}	Power Consumption (1)	3V	No load, Non-printing $T_a\leq +20^{\circ}\text{C}$	—	2	3	μA
V _L	Lamp Drop Voltage (Reference VDD)	3V	Constant voltage reference V _{DD} , at V _{DD} =2.4V~5.5V (Load is lamp 1.8V/40mA)	1.71	1.8	1.89	V
I _{opr2}	Power Consumption (2)	3V	No load, Non-printing $T_a\leq +50^{\circ}\text{C}$, $\text{RH}=80\%$	—	—	9	μA
$\Delta T0/T$	Time Accuracy	3V	$T_a=+20^{\circ}\text{C}$	-90	0	90	sec/ Month
$\Delta T1/T$	Time Accuracy Deviation (1)	3V	$T_a=-10^{\circ}\text{C}$, Deviation against $T_a=+20^{\circ}\text{C}$	-170	-112	-70	sec/ Month
$\Delta T2/T$	Time Accuracy Deviation (2)	3V	$T_a=+35^{\circ}\text{C}$, Deviation against $T_a=+20^{\circ}\text{C}$	-25	-8	0	sec/ Month
$\Delta T3/T$	Time Accuracy Deviation (3)	3V	$T_a=+50^{\circ}\text{C}$, Deviation against $T_a=+20^{\circ}\text{C}$	-95	-55	-10	sec/ Month
Thold	Data Hold Time	3V	At power interrupt (0.1 μF at 3V)	1	—	—	s
I key-on	ON Recognition Current	3V	When $V_{SS}=0\text{V}$, X pin ($V_{SS}+0.5\text{V}$), Other pins	30 10	— —	— —	μA μA
R key-off	OFF Recognition Resistance	3V	X pin, Other pins	3 10	— —	— —	M Ω M Ω
V _{IL}	Threshold Voltage	3V	X Pin ON function With MODE, SEL, SET ON	V _{SS}	—	V _{SS} +0.5V	V
V _{IH}	Threshold Voltage	3V	With X pin OFF MODE, SEL, SET OFF function	V _{DD} -0.5V	—	V _{DD}	V

Functional Description

- 6-digit timer in 5 modes: Mode selection for 3 key applications
- Date from 1-1-'98 to 31-12-'49 (2049) automatic updating, including leap years.
- Matrix address LCD interface in 1/3 duty, 1/2 bias, frame frequency is 43Hz.
- Printing enable is "Go low" trigger in X input. $V_X \leq 1/2 V_{DD}$, Debounce in printing trigger: $1ms \leq T_{DEBOUNCE} \leq 2ms$.
- After printing, "_" will blink 3 times at 1Hz rate.
- Print means lamp output "LOW" to light lamp. Lamp output sink current is 40mA Min. (Constant current source), typical 45mA ($V_{DD}=2.4V \sim 5.5V$).
- Printing time: 30ms, 45ms, 60ms or programmable (determined by the control CPU of the camera), selected by D or T and Topt inputs.
- Built-in crystal (32768Hz) oscillator circuit (capacitor and resistor).
- At "OFF" mode (- - - - -), printing (Lamp on) and data setting is inhibited in any case and printing "_" mark OFF.

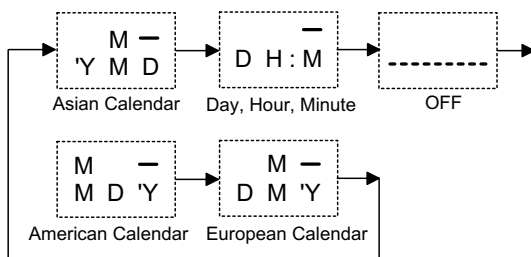

- Default value at power on is " '98 1 1 " (ASIAN DATE).
- Date and time cannot be set with printing "_" mark ON.
- LCD segment test pin is provided, a "SEGON" is pull-low which will force all segments ON. This test pin is normally pull-high through an on chip 1kΩ resistor.
- ":" mark is still at time mode, at time setting, "digit" selected by SEL pin will blink at 1Hz and 1/2 duty rate.
- At setting mode (SET), printing "_" mark is OFF and printing is inhibited.
- The selected digit (blinking) count up by one at short intervals ($1.0sec \leq T_{SET} \leq 1.25sec$), when the ON key is pressed for less than 1.0sec; if the SET key is pressed longer than 1.25sec, the digit will count up rapidly at 8Hz rate.
- Printing is disabled during data and time setting.

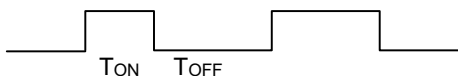

Debounce time of MODE, SEL, SET key is:
 ON recognition: when the ON key is pressed longer than T_{ON} , ON is recognized.

$$31.25ms \leq T_{ON} \leq 62.5ms,$$

OFF recognition: when the ON key is pressed longer than T_{OFF} , OFF is recognized; the next input has to wait.

$$31.25ms \leq T_{OFF} \leq 62.5ms,$$

- If at least one key-ON time pulse is detected during the " T_{OFF} " period, the time before the key-ON pulse is regarded as the key-ON time.
 The lamp light-up time is controlled depending on the levels of D and T pins.

D	T	Lamp signal output time
H	H	60ms
H	L	30ms
L	H	Depend on X input pulse width
L	L	45ms

- "X" pin must be carefully protected, the system cannot be reset when in $\pm 200V$ and 200pF one-shot test. (add external resistor 10kΩ series with the pad; it's better if it works well without the resistor)
- At "OFF" mode, no data can be set.
- The X input is rejected in some condition, such as:
 - OFF mode
 - Selection and Setting mode (In these condition the lamp must be turned off)
- Power on reset and after crystal is stable (max. 2 sec)
- Regulator output voltage accuracy is $2V \pm 3.0\%$ (after TRIM)
- Display in Day-Hour-Minute mode, in 24-hour system (0~23)

Operation flowchart

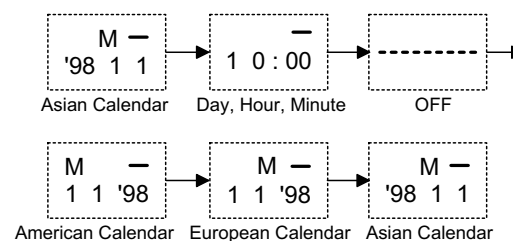

Mode selection sequence and initial value: ("MODE" key)

In digit setting, press the "SET" key

- The digit selected will blink at a 1hz rate.
- The blinking digit (selected digit) will count up by itself.
- If "SET" key is pressed $\geq 1sec$, the digit will count up rapidly at an 8Hz rate, otherwise count up by 1 every time it's pressed ($\leq 1sec$).
- When the colon (":") is blinking in the Day-Hour-Minute mode, pressing the SET key will reset the seconds to 00.

- When digit is set, the MODE key can interrupt the setting mode and change to the next mode.
- Real time clock must count at any time even in change mode or adjusting mode.
- IN 3-key application, connect SWK to VSS and SEL. Press the switch MODE to change the mode as shown on the chart below, press SEL to select resetting data, press SET key to adjust the selected data. To select digit, press selection key ("SEL" key), "-" mark is OFF during selection.

- At calendar mode, no matter what style calendar is displayed. The sequence of selected digit is always "Year→Month→Day→Normal" state. The selected digit will blink at a 2Hz rate.
- At time mode, Day is not selected. The sequence of the selected digit is "Hour→Minute→Normal" state.

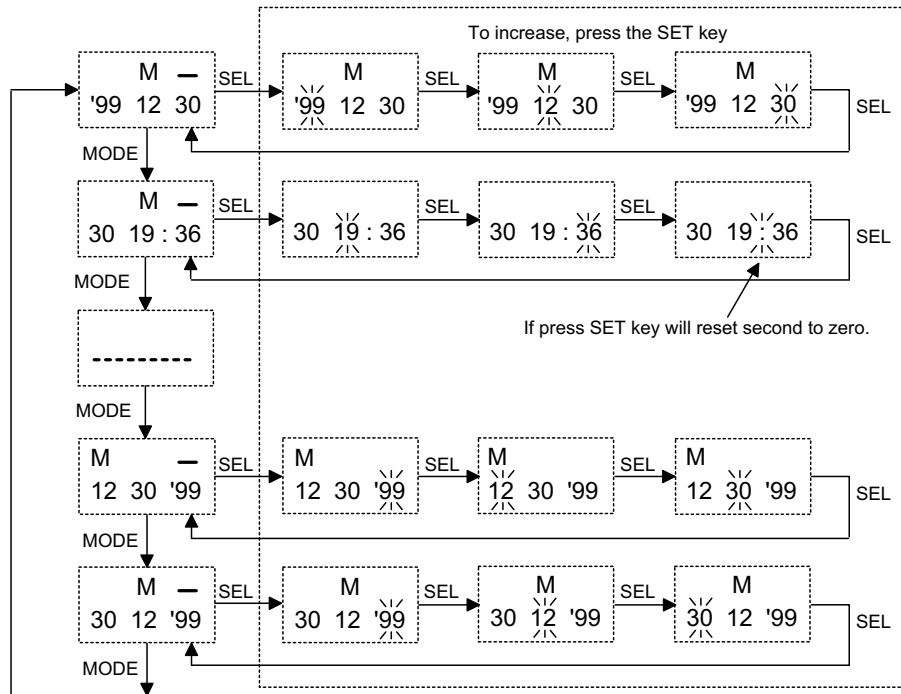

LCD segment format

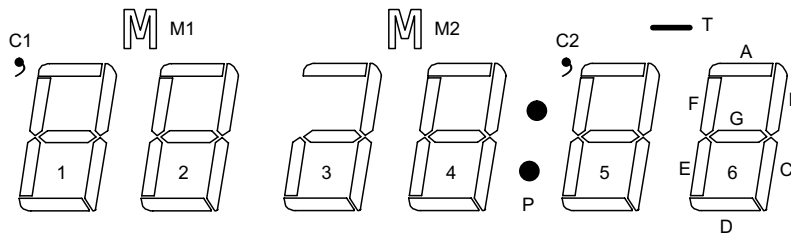

Pin No.	1	2	3	4	5	6	7	8	9	10	11	12	13	14	15	16	17	18
SEG		1	2	3	4	5	6	7	8	9	10	11	12	13	14	15		
	COM1	1A 1D	1B	C1	2F	2A	3A 3D	M2	4F	4A	C2	5A 5D	5B	T	6A	—		
		1E	1C	2E	2D	2C	3E	3C	4D	4C	P	5E	5C	6E	6D	6C		COM3
		1F	1G	M1	2G	2B	3G	3B	4E	4G	4B	5F	5G	6F	6G	6B	COM3	

Application Circuits

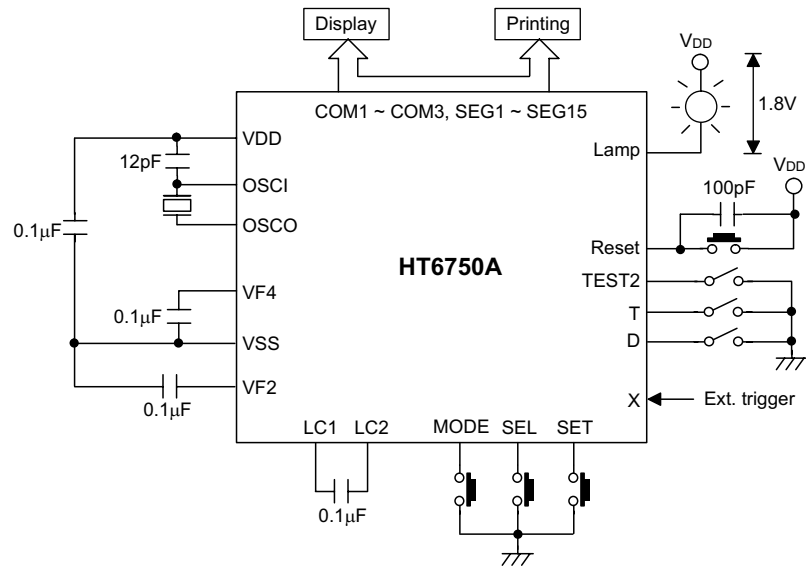

Holtek Semiconductor Inc. (Headquarters)

No.3, Creation Rd. II, Science Park, Hsinchu, Taiwan
Tel: 886-3-563-1999
Fax: 886-3-563-1189
<http://www.holtek.com.tw>

Holtek Semiconductor Inc. (Taipei Sales Office)

4F-2, No. 3-2, YuanQu St., Nankang Software Park, Taipei 115, Taiwan
Tel: 886-2-2655-7070
Fax: 886-2-2655-7373
Fax: 886-2-2655-7383 (International sales hotline)

Holtek Semiconductor Inc. (Shanghai Sales Office)

7th Floor, Building 2, No.889, Yi Shan Rd., Shanghai, China 200233
Tel: 021-6485-5560
Fax: 021-6485-0313
<http://www.holtek.com.cn>

Holtek Semiconductor Inc. (Shenzhen Sales Office)

43F, SEG Plaza, Shen Nan Zhong Road, Shenzhen, China 518031
Tel: 0755-8346-5589
Fax: 0755-8346-5590
ISDN: 0755-8346-5591

Holtek Semiconductor Inc. (Beijing Sales Office)

Suite 1721, Jinyu Tower, A129 West Xuan Wu Men Street, Xicheng District, Beijing, China 100031
Tel: 010-6641-0030, 6641-7751, 6641-7752
Fax: 010-6641-0125

Holmate Semiconductor, Inc. (North America Sales Office)

46712 Fremont Blvd., Fremont, CA 94538
Tel: 510-252-9880
Fax: 510-252-9885
<http://www.holmate.com>

Copyright © 2003 by HOLTEK SEMICONDUCTOR INC.

The information appearing in this Data Sheet is believed to be accurate at the time of publication. However, Holtek assumes no responsibility arising from the use of the specifications described. The applications mentioned herein are used solely for the purpose of illustration and Holtek makes no warranty or representation that such applications will be suitable without further modification, nor recommends the use of its products for application that may present a risk to human life due to malfunction or otherwise. Holtek's products are not authorized for use as critical components in life support devices or systems. Holtek reserves the right to alter its products without prior notification. For the most up-to-date information, please visit our web site at <http://www.holtek.com.tw>.