



### GENERAL DESCRIPTION



The ICS83948I-01 is a low skew, 1-to-12 Differential-to-LVCMOS Fanout Buffer and a member of the HiPerClockS™ family of High Performance Clock Solutions from ICS. The ICS83948I-01 has two selectable clock inputs. The CLK, nCLK pair can accept most standard differential input levels. The LVCMOS\_CLK can accept LVCMOS or LVTTTL input levels. The low impedance LVCMOS outputs are designed to drive 50Ω series or parallel terminated transmission lines. The effective fanout can be increased from 12 to 24 by utilizing the ability of the outputs to drive two series terminated lines.

The ICS83948I-01 is characterized at 3.3V core/3.3V output. Guaranteed output and part-to-part skew characteristics make the ICS83948I-01 ideal for those clock distribution applications demanding well defined performance and repeatability.

### FEATURES

- 12 LVCMOS outputs
- Selectable LVCMOS clock or differential CLK, nCLK inputs
- CLK, nCLK pair can accept the following differential input levels: LVDS, LVPECL, LVHSTL, SSTL, HCSL
- LVCMOS\_CLK accepts the following input levels: LVCMOS or LVTTTL
- Maximum output frequency: 150MHz
- Output skew: 350ps (maximum)
- Part to part skew: 1.5ns (maximum)
- 3.3V core, 3.3V output
- -40°C to 85°C ambient operating temperature
- Pin compatible with the MPC948/948L

### BLOCK DIAGRAM

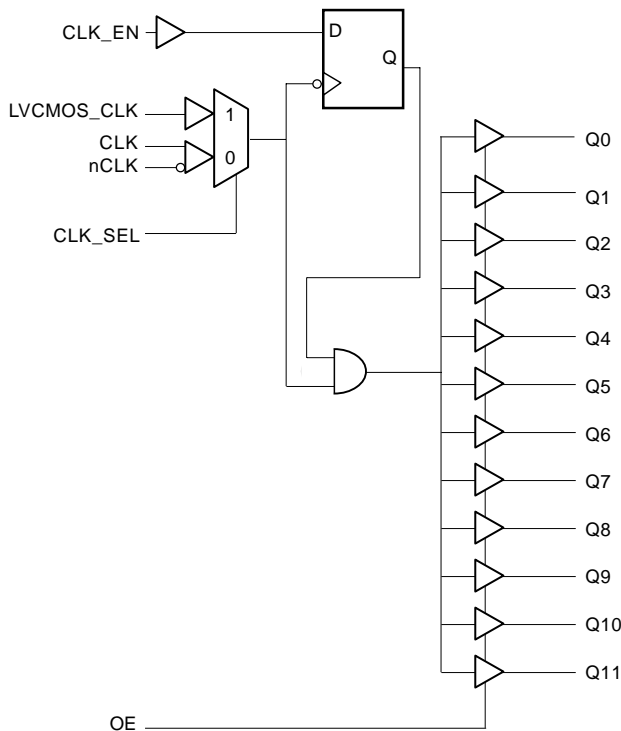

### PIN ASSIGNMENT

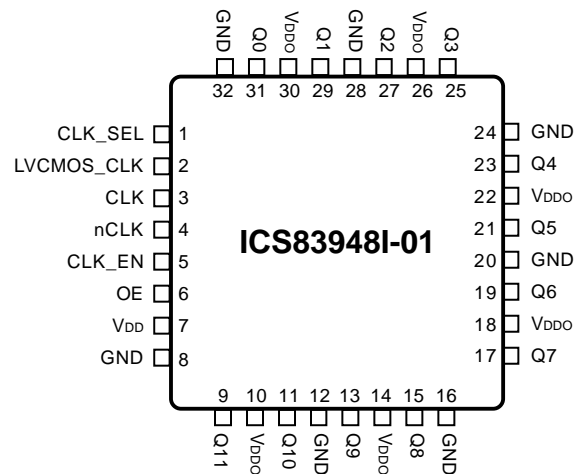

**32-Lead LQFP**  
7mm x 7mm x 1.4mm package body  
**Y Package**  
Top View



**TABLE 1. PIN DESCRIPTIONS**

Number	Name	Type		Description
1	CLK_SEL	Input	Pullup	Clock select input. Selects LVCMOS clock input when HIGH. Selects CLK, nCLK inputs when LOW. LVCMOS / LVTTTL interface levels.
2	LVCMOS_CLK	Input	Pullup	Clock input. LVCMOS / LVTTTL interface levels.
3	CLK	Input	Pullup	Non-inverting differential clock input.
4	nCLK	Input	Pulldown	Inverting differential clock input.
5	CLK_EN	Input	Pullup	Clock enable. LVCMOS / LVTTTL interface levels.
6	OE	Input	Pullup	Output enable. LVCMOS / LVTTTL interface levels.
7	V <sub>DD</sub>	Power		Core supply pin.
8, 12, 16, 20, 24, 28, 32	GND	Power		Power supply ground.
9, 11, 13, 15, 17, 19, 21, 23 25, 27, 29, 31	Q11, Q10, Q9, Q8, Q7, Q6, Q5, Q4, Q3, Q2, Q1, Q0	Output		Clock outputs. LVCMOS / LVTTTL interface levels.
10, 14, 18, 22, 26, 30	V <sub>DDO</sub>	Power		Output supply pins.

NOTE: *Pullup* and *Pulldown* refer to internal input resistors. See Table 2, Pin Characteristics, for typical values.

**TABLE 2. PIN CHARACTERISTICS**

Symbol	Parameter	Test Conditions	Minimum	Typical	Maximum	Units
C <sub>IN</sub>	Input Capacitance				4	pF
C <sub>PD</sub>	Power Dissipation Capacitance (per output)			25		pF
R <sub>PULLUP</sub>	Input Pullup Resistor			51		KΩ
R <sub>PULLDOWN</sub>	Input Pulldown Resistor			51		KΩ
R <sub>OUT</sub>	Output Impedance			7		Ω

**TABLE 3A. CLOCK SELECT FUNCTION TABLE**

Control Input	Clock	
CLK_SEL	CLK, nCLK	LVCMOS_CLK
0	Selected	De-selected
1	De-selected	Selected

**TABLE 3B. CLOCK INPUT FUNCTION TABLE**

Inputs				Outputs	Input to Output Mode	Polarity
CLK_SEL	LVCMOS_CLK	CLK	nCLK	Q0:Q12		
0	—	0	1	LOW	Differential to Single Ended	Non Inverting
0	—	1	0	HIGH	Differential to Single Ended	Non Inverting
0	—	0	Biased; NOTE 1	LOW	Single Ended to Single Ended	Non Inverting
0	—	1	Biased; NOTE 1	HIGH	Single Ended to Single Ended	Non Inverting
0	—	Biased; NOTE 1	0	HIGH	Single Ended to Single Ended	Inverting
0	—	Biased; NOTE 1	1	LOW	Single Ended to Single Ended	Inverting
1	0	—	—	LOW	Single Ended to Single Ended	Non Inverting
1	1	—	—	HIGH	Single Ended to Single Ended	Non Inverting

NOTE 1: Please refer to the Application Information section, "Wiring the Differential Input to Accept Single Ended Levels".



**ABSOLUTE MAXIMUM RATINGS**

Supply Voltage, $V_{DD}$	4.6V
Inputs, $V_I$	-0.5V to $V_{DD} + 0.5V$
Outputs, $V_O$	-0.5V to $V_{DDO} + 0.5V$
Package Thermal Impedance, $\theta_{JA}$	47.9°C/W (0 lfpm)
Storage Temperature, $T_{stg}$	-65°C to 150°C

Stresses beyond those listed under Absolute Maximum Ratings may cause permanent damage to the device. These ratings are stress specifications only. Functional operation of product at these conditions or any conditions beyond those listed in the *DC Characteristics* or *AC Characteristics* is not implied. Exposure to absolute maximum rating conditions for extended periods may affect product reliability.

**TABLE 4A. POWER SUPPLY CHARACTERISTICS,  $V_{DD} = V_{DDO} = 3.3V \pm 0.3V$ ,  $T_A = -40^\circ$  TO  $85^\circ$**

Symbol	Parameter	Test Conditions	Minimum	Typical	Maximum	Units
$V_{DD}$	Input Supply Voltage		3.0	3.3	3.6	V
$V_{DDO}$	Output Supply Voltage		3.0	3.3	3.6	V
$I_{DD}$	Quiescent Supply Current				55	mA

**TABLE 4B. DC CHARACTERISTICS,  $V_{DD} = V_{DDO} = 3.3V \pm 0.3V$ ,  $T_A = -40^\circ$  TO  $85^\circ$**

Symbol	Parameter	Test Conditions	Minimum	Typical	Maximum	Units
$V_{IH}$	Input High Voltage	LVCMOS/LVTTL	2		3.6	V
$V_{IL}$	Input Low Voltage	LVCMOS/LVTTL			0.8	V
$V_{PP}$	Peak-to-Peak Input Voltage	CLK, nCLK	0.15		1.3	V
$V_{CMR}$	Input Common Mode Voltage; NOTE 1, 2	CLK, nCLK	GND + 0.5		$V_{DD} - 0.85$	V
$I_{IN}$	Input Current				$\pm 100$	$\mu A$
$V_{OH}$	Output High Voltage	$I_{OH} = -20mA$	2.5			V
$V_{OL}$	Output Low Voltage	$I_{OL} = 20mA$			0.4	V

NOTE 1: For single ended applications, the maximum input voltage for CLK, nCLK is  $V_{DD} + 0.3V$ .

NOTE 2: Common mode voltage is defined as  $V_{IH}$ .



**TABLE 5. AC CHARACTERISTICS,  $V_{DD} = V_{DDO} = 3.3V \pm 0.3V$ ,  $T_A = -40^\circ$  TO  $85^\circ$**

Symbol	Parameter	Test Conditions	Minimum	Typical	Maximum	Units
$f_{MAX}$	Maximum Output Frequency		150			MHz
$t_{PD}$	Propagation Delay	CLK, nCLK; NOTE 1A	2.5		6.5	ns
		LVCMOS_CLK; NOTE 1B	3		5.5	ns
$t_{sk(o)}$	Output Skew; NOTE 2, 6	Measured on rising edge @ $V_{DDO}/2$			350	ps
$t_{sk(pp)}$	Part-to-Part Skew; NOTE 3, 6	CLK, nCLK	Measured on rising edge @ $V_{DDO}/2$		1.5	ns
		LVCMOS_CLK			2	ns
$t_R$	Output Rise Time	0.8V to 2V	0.2		1.0	ns
$t_F$	Output Fall Time	0.8V to 2V	0.2		1.0	ns
$t_{PW}$	Output Pulse Width		$t_{Period}/2 - 800$		$t_{Period}/2 + 800$	ps
$t_{PZL}, t_{PZH}$	Output Disable Time; NOTE 4				11	ns
$t_{PLZ}, t_{PHZ}$	Output Enable Time; NOTE 4				11	ns
$t_S$	Clock Enable Setup Time; NOTE 5	CLK_EN to CLK	1			ns
		CLK_EN to LVCMOS_CLK	0			ns
$t_H$	Clock Enable Hold Time; NOTE 5	CLK to CLK_EN	0			ns
		LVCMOS_CLK to CLK_EN	1			ns

NOTE 1A: Measured from the differential input crossing point to  $V_{DDO}/2$  of the output.

NOTE 1B: Measured from the  $V_{DD}/2$  of the input to  $V_{DDO}/2$  of the output.

NOTE 2: Defined as skew between outputs at the same supply voltage and with equal load conditions.  
Measured at  $V_{DDO}/2$ .

NOTE 3: Defined as skew between outputs on different devices operating at the same supply voltages and with equal load conditions. Using the same type of inputs on each device, the outputs are measured at  $V_{DDO}/2$ .

NOTE 4: These parameters are guaranteed by characterization. Not tested in production.

NOTE 5: Setup and Hold times are relative to the falling edge of the input clock.

NOTE 6: This parameter is defined in accordance with JEDEC Standard 65.



## PARAMETER MEASUREMENT INFORMATION

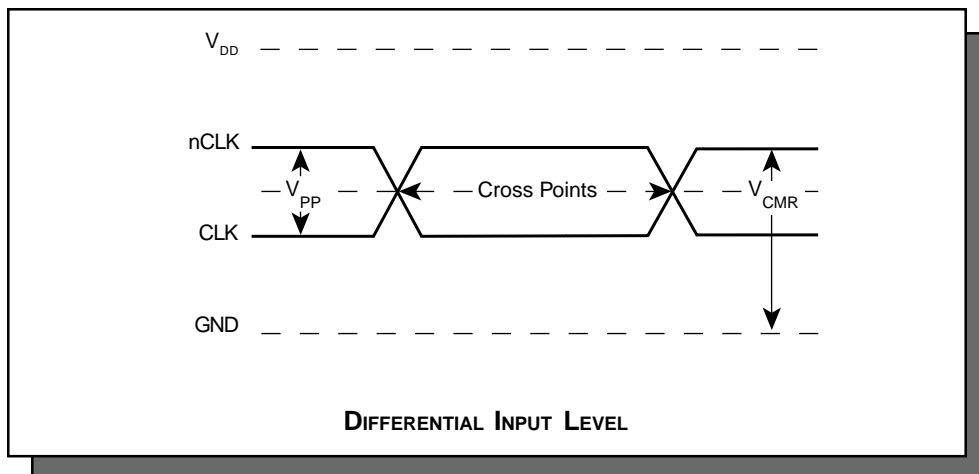
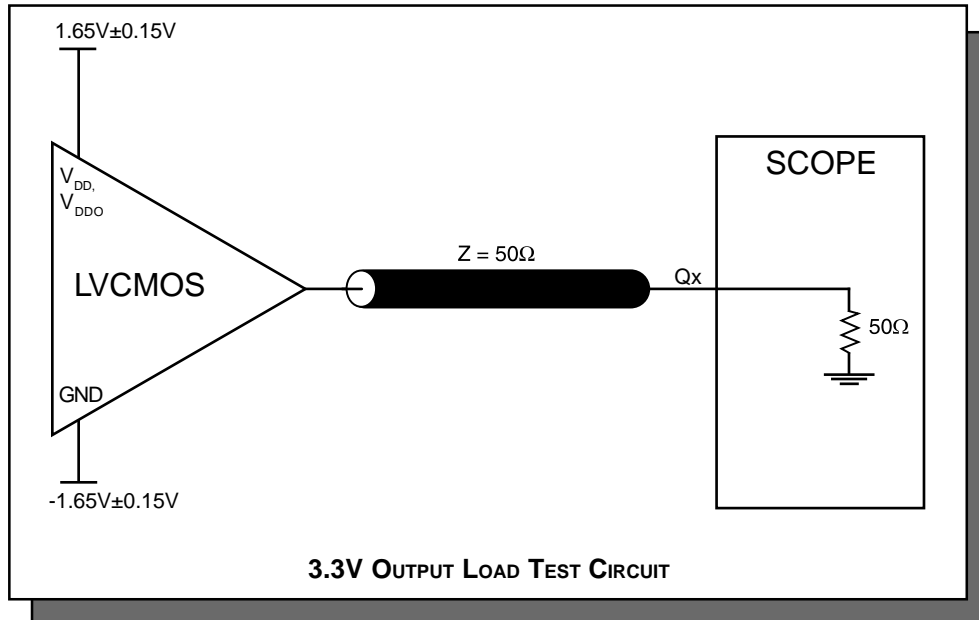

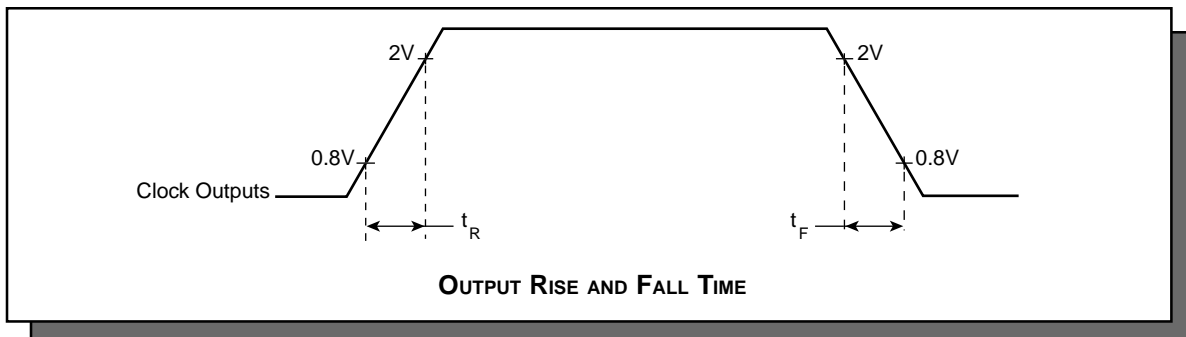
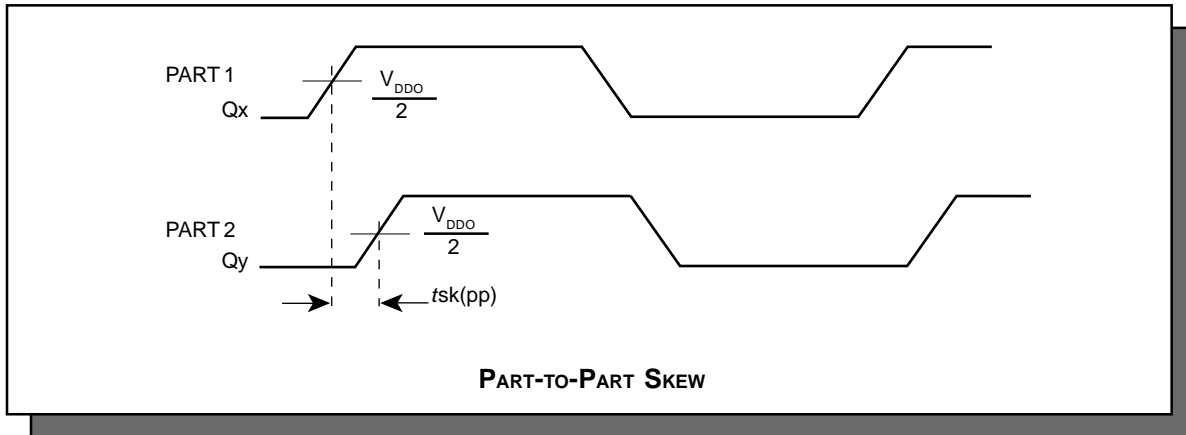
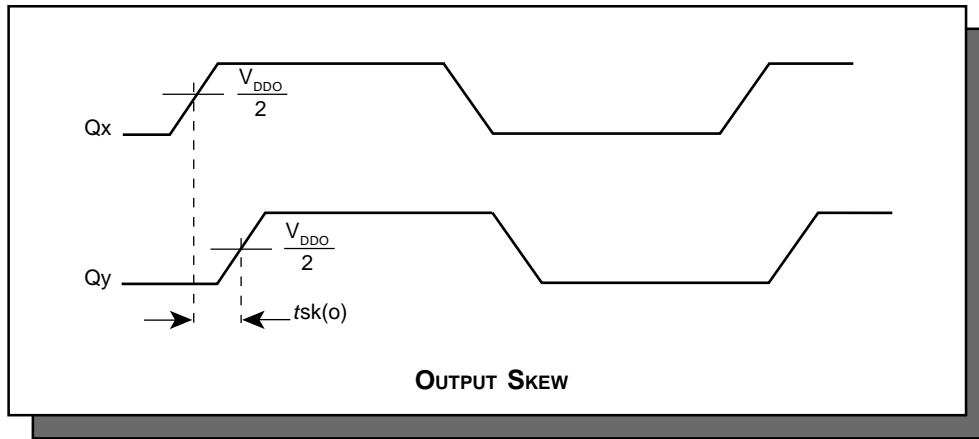

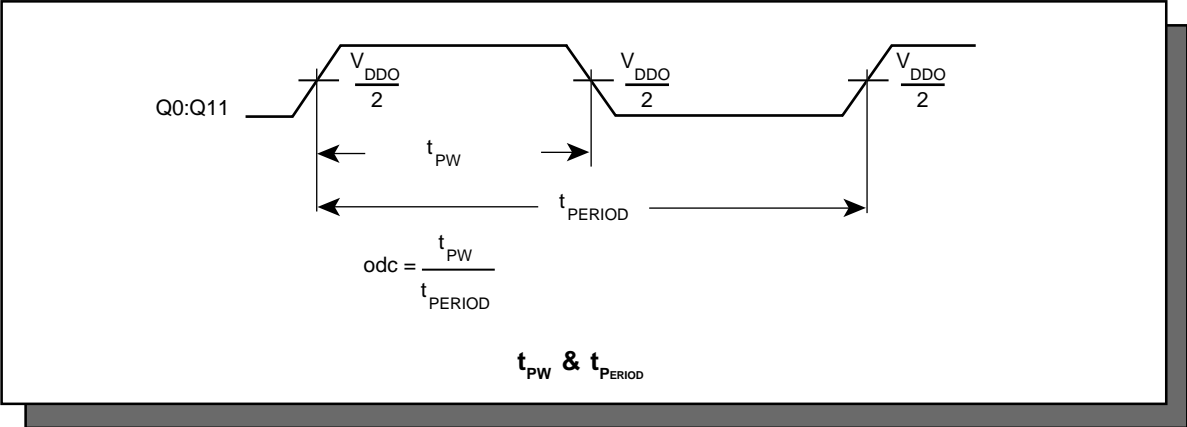
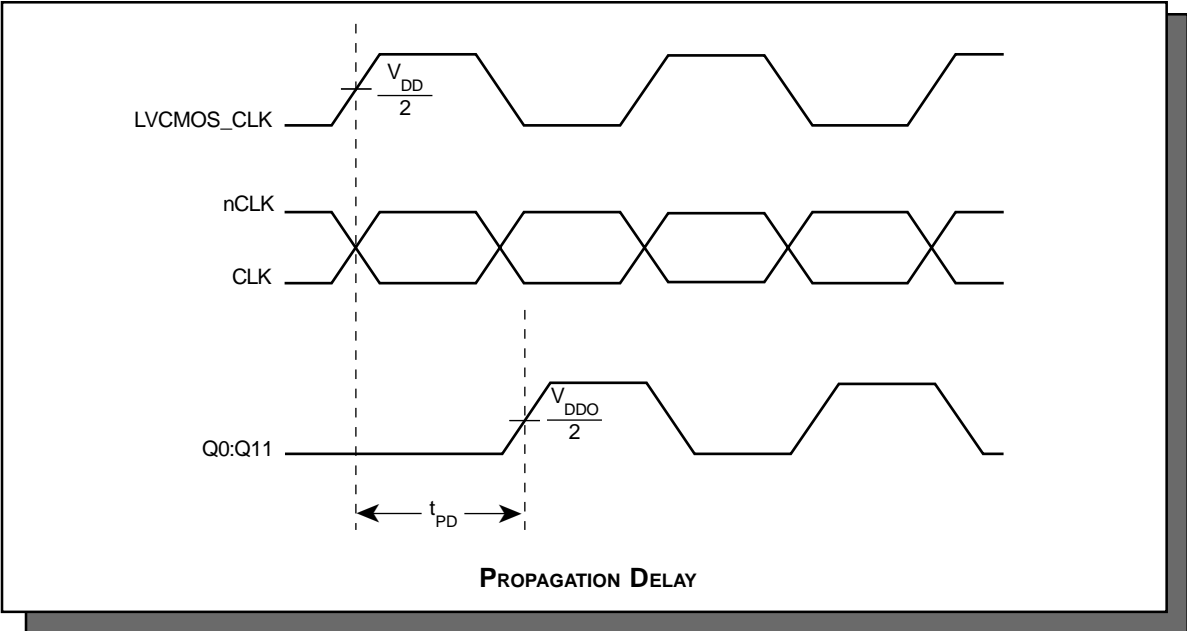



## APPLICATION INFORMATION

### WIRING THE DIFFERENTIAL INPUT TO ACCEPT SINGLE ENDED LEVELS

Figure 2 shows how the differential input can be wired to accept single ended levels. The reference voltage  $V_{REF} = V_{DD}/2$  is generated by the bias resistors R1, R2 and C1. This bias circuit should be located as close as possible to the input pin. The ratio of R1 and R2 might need to be adjusted to position the  $V_{REF}$  in the center of the input voltage swing. For example, if the input clock swing is only 2.5V and  $V_{DD} = 3.3V$ ,  $V_{REF}$  should be 1.25V and  $R2/R1 = 0.609$ .

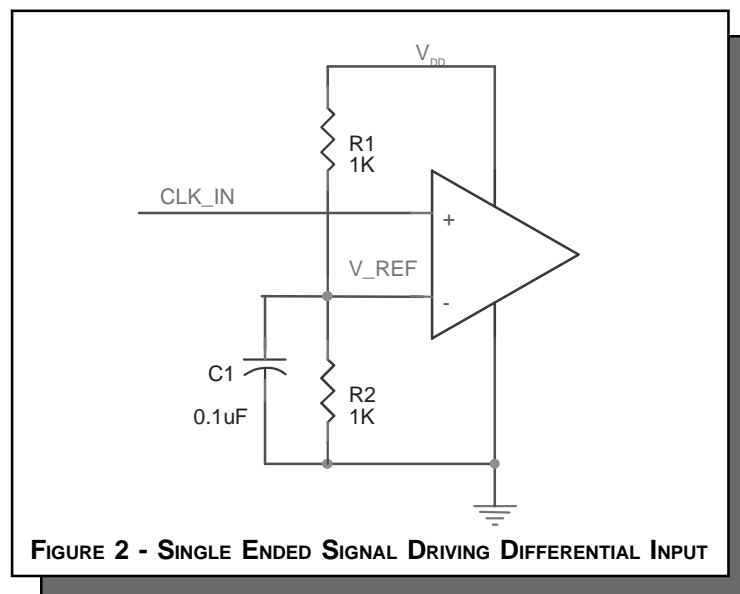





## RELIABILITY INFORMATION

TABLE 6.  $\theta_{JA}$  VS. AIR FLOW TABLE

$\theta_{JA}$ by Velocity (Linear Feet per Minute)			
	0	200	500
Single-Layer PCB, JEDEC Standard Test Boards	67.8°C/W	55.9°C/W	50.1°C/W
Multi-Layer PCB, JEDEC Standard Test Boards	47.9°C/W	42.1°C/W	39.4°C/W

**NOTE:** Most modern PCB designs use multi-layered boards. The data in the second row pertains to most designs.

### TRANSISTOR COUNT

The transistor count for ICS83948I-01 is: 1040



PACKAGE OUTLINE - Y SUFFIX

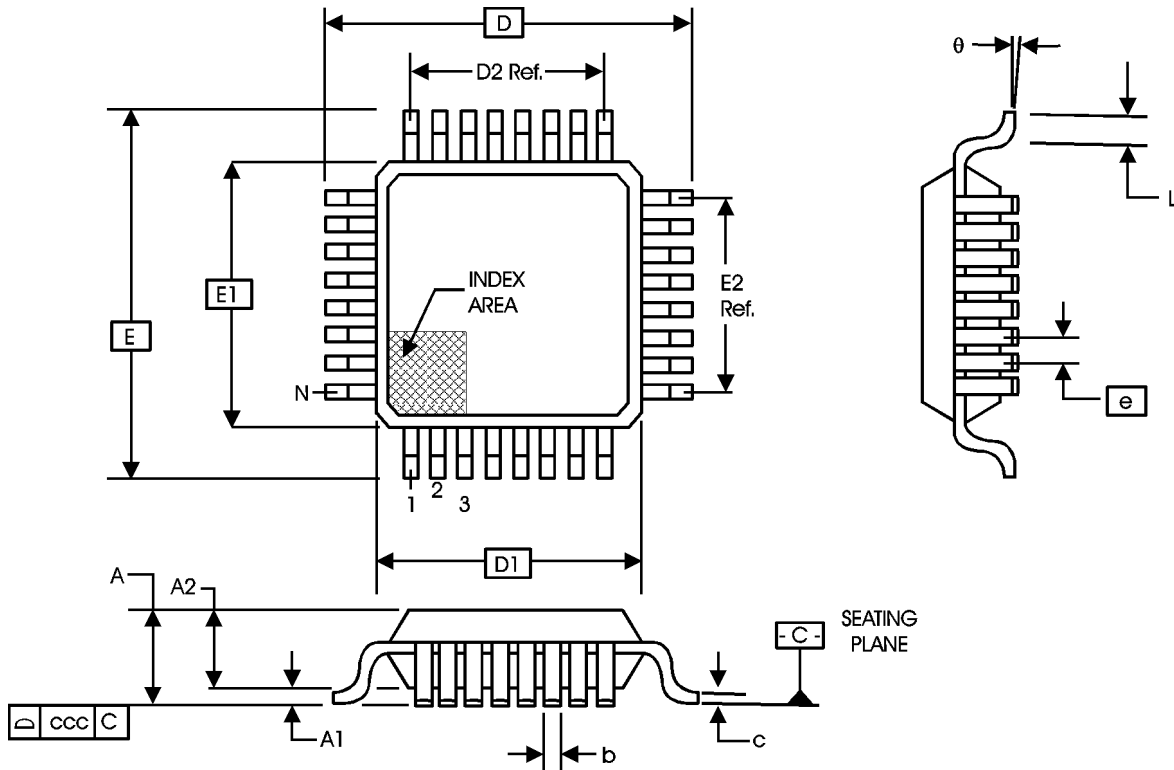

TABLE 7. PACKAGE DIMENSIONS

JEDEC VARIATION ALL DIMENSIONS IN MILLIMETERS			
SYMBOL	BBA		
	MINIMUM	NOMINAL	MAXIMUM
N	32		
A	--	--	1.60
A1	0.05	--	0.15
A2	1.35	1.40	1.45
b	0.30	0.37	0.45
c	0.09	--	0.20
D	9.00 BASIC		
D1	7.00 BASIC		
D2	5.60 Ref.		
E	9.00 BASIC		
E1	7.00 BASIC		
E2	5.60 Ref.		
e	0.80 BASIC		
L	0.45	0.60	0.75
θ	0°	--	7°
ccc	--	--	0.10

REFERENCE DOCUMENT: JEDEC PUBLICATION 95, MS-026



Integrated  
Circuit  
Systems, Inc.

# ICS83948I-01

## LOW SKEW, 1-TO-12 DIFFERENTIAL-TO-LVCMOS FANOUT BUFFER

**TABLE 8. ORDERING INFORMATION**

Part/Order Number	Marking	Package	Count	Temperature
ICS83948AYI-01	ICS83948AYI01	32 Lead LQFP	250 per tray	-40°C to 85°C
ICS83948AYI-01T	ICS83948AYI01	32 Lead LQFP on Tape and Reel	1000	-40°C to 85°C

While the information presented herein has been checked for both accuracy and reliability, Integrated Circuit Systems, Incorporated (ICS) assumes no responsibility for either its use or for infringement of any patents or other rights of third parties, which would result from its use. No other circuits, patents, or licenses are implied. This product is intended for use in normal commercial and industrial applications. Any other applications such as those requiring high reliability, or other extraordinary environmental requirements are not recommended without additional processing by ICS. ICS reserves the right to change any circuitry or specifications without notice. ICS does not authorize or warrant any ICS product for use in life support devices or critical medical instruments.